

## A Commercial Low Cost Highly Efficient UC3842 based High Brightness LED (HBLED) Lamp

Devi V<sup>1</sup>, Sreedevi V T<sup>2</sup>

School of Electrical and Electronics Engineering, VIT University

---

### Article Info

#### Article history:

Received Jun 16, 2017

Revised Dec 13, 2017

Accepted Jan 3, 2018

---

#### Keywords:

High brightness light emitting diodes

Peak current mode controller

Power factor correction

SEPIC converter

---

### ABSTRACT

The conventional lighting sources like incandescent and fluorescent lamps are replaced by High Brightness Light Emitting Diodes (HB-LEDs). In this paper, a HBLED driver using a Single Ended Primary Inductor Converter (SEPIC) with input Power Factor Correction (PFC) is presented. PFC is accomplished using a commercial inexpensive Peak Current Mode Controller (PCMC) IC UC3842 is newly combined with SEPIC converter. Extensive simulation results are carried out and a laboratory prototype to power 18W LED array from AC mains is implemented and the results are presented in detail.

Copyright © 2018 Institute of Advanced Engineering and Science.  
All rights reserved.

---

### Corresponding Author:

Devi V,

School of Electrical and Electronics Engineering, VIT University

Chennai, India.

Email: devimaheswaran.v@gmail.com

---

## 1. INTRODUCTION

The conventional lighting sources like incandescent and fluorescent lamps are replaced by High Brightness Light Emitting Diodes (HB-LEDs). These are popular due to its high efficiency and longevity [1-3]. The brightness of LED is directly related to its forward current and LED is powered by dc. A small variation in the driving voltage can lead to a major variation in the LED current. Since this large variation would affect the reliability of the LEDs, a regulated current control is needed to achieve constant brightness of LEDs. The current regulation is achieved by DC-DC power converters like buck, boost and buck-boost, which are known as LED drivers [4,6]. In this work, a Single Ended Primary Inductor Converter (SEPIC) is used as LED driver because it can provide a non-inverting output voltage and it can be higher or lower than the input voltage [7-9]. An uncontrolled diode bridge rectifier is needed to convert the available ac voltage to a regulated dc voltage for the LED driver. But due to the bridge rectifier, the input current is distorted and the input power factor is poor. To track the input current with the ac input voltage, there is a necessity for input Power Factor Correction (PFC). A high input power factor is required by regulation standards for most commercial luminaries [10]. All lighting products with input power higher than 25W, with AC-DC led drivers must comply with line harmonic limits set by IEC 6100-3-2 class C. Therefore HB-LED driver circuits are designed to achieve high input power factor and many control strategies are available in the literature for PFC [11-15].

This work focuses on a SEPIC based LED driver with input PFC using a commercial Peak Current Mode Controlled (PCMC) IC UC3842 as a new combination. The control IC is inexpensive with which PCMC operation is possible. PCMC is well established in literature for PFC, fast transient response and ease of implementation[16-17]. Extensive simulation results are carried out to achieve near unity power factor and a hardware prototype of 18W is fabricated in the laboratory to validate the theoretical approach. The rest of the paper is organised as follows. Section 2 explains the block diagram and basic operation of a PCMC

SEPIC converter based LED driver. Design considerations of SEPIC converter are provided in Section 3. Simulation and experimental results are presented in Section 4 and the paper is concluded in Section 5.

## 2. RESEARCH METHOD

The block diagram of SEPIC based PFC circuit using PCMC IC 3842 is shown in Figure 1. It consists of a diode bridge rectifier which is supplied from the input ac voltage,  $V_{ac}$ . The output of the diode bridge rectifier is the input to the SEPIC dc-dc converter. The SEPIC converter drives the LED array and the operation is discussed below: The SEPIC converter consists of a switch  $S$ , inductors  $L_1$  and  $L_2$ , capacitors  $C_1$ ,  $C_2$  and a diode,  $D$ . When the switch  $S$  is turned ON, the inductor  $L_2$  is charged from the input voltage source during this time. The inductor  $L_1$  takes energy from the capacitor,  $C_1$  and the output capacitor,  $C_2$  is left to provide the load current while diode,  $D$  is reverse biased. No energy is supplied to the output capacitor during this time. When the switch,  $S$  is turned OFF, diode  $D$  is forward biased; the inductor,  $L_1$  charges the capacitor,  $C_1$  and also provides current to the load. Also during this time, the inductor,  $L_2$  is connected to the load. *i.e.*, Both the inductors provide current to the output capacitor,  $C_2$ .

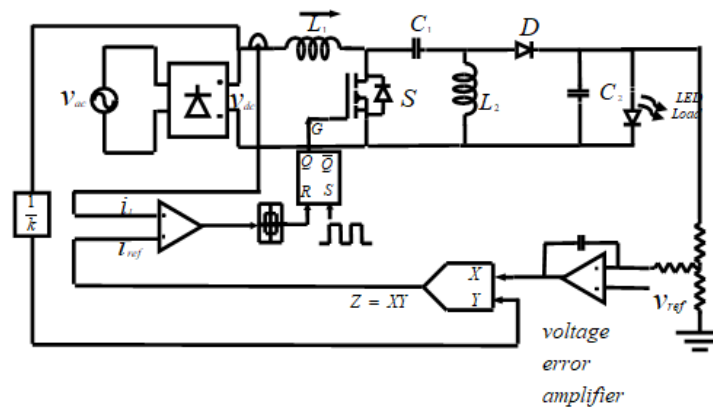

Figure 1. Block diagram of HBLED driver using SEPIC based PFC circuit

The second stage consists of a control part using PCMC IC 3842 as shown in Figure 1. It consists of a voltage error amplifier which compares the actual output voltage,  $V_o$  and the reference voltage,  $V_{ref}$ . The error obtained from the comparator and the rectified feed forward input voltage is multiplied to obtain the reference current,  $\dot{i}_{ref}$  for the inner current loop. The input current,  $\dot{i}_l$  is compared and the error of this comparison is processed and used to generate the gate pulses for the switch,  $S$ . The inner loop is used for shaping the inductor current with the applied voltage and the outer loop controls the output voltage and keeps it constant at the pre-defined reference value. In order to generate gate pulses for the switch  $S$ , the inductor current,  $\dot{i}_l$  is compared with the reference current,  $\dot{i}_{ref}$ . A clock signal is provided to turn ON the switch at constant frequency, and the switch is turned OFF when sum of the positive ramp of the inductor current and a compensating ramp reaches the reference current. Specifically when the switch is ON, the inductor current increases and when it reaches  $\dot{i}_{ref}$ , the switches are turned OFF, thereby causing the inductor current to ramp down until the next clock pulse sets in.

The output voltage of SEPIC converter is given by,

$$V_o = \frac{D}{1-D} V_{dc} \quad (1)$$

$V_o$  is the output voltage,  $V_{dc}$  is the input given to SEPIC converter.

The duty cycle ( $D$ ) is given by,

$$D = \frac{V_o + V_D}{V_{dc} + V_o + V_D} \quad (2)$$

Where  $V_D$  is the diode forward voltage drop, The ripple current in inductors can be assumed as,

$$\Delta I_{L1} = 40\% \text{ of } I_{L1(\max)} \quad (3)$$

Hence the inductor values,  $L_1$  and  $L_2$  is calculated by

$$L_1 = L_2 = \left( \frac{V_{dc}}{\Delta I_{L1} f_{sw}} \right) D \quad (4)$$

Where  $f_{sw}$  is the switching frequency. To avoid saturation in the inductors, the peak current, is given by

$$I_{L1pk} = \left( 1 + \frac{40\%}{2} \right) \left( \frac{V_o + V_D}{V_{dc}} \right) I_o \quad (5)$$

$$I_{L2pk} = \left( 1 + \frac{40\%}{2} \right) I_o \quad (6)$$

$I_o$  is the load current

The SEPIC capacitor  $C_1$  should be capable of withstanding large RMS values of current with respect to power output. Therefore the voltage rating of the capacitor  $C_1$  must be greater than maximum input voltage.

The RMS current of the capacitor  $C_1$  is given by

$$I_{C1(rms)} = \sqrt{\left( \frac{V_o + V_D}{V_{dc}} \right) I_o} \quad (7)$$

The peak to peak ripple voltage on capacitor  $C_1$  is given by

$$\Delta V_{C1} = \frac{I_o D}{C_1 f_{sw}} \quad (8)$$

The output capacitor,  $C_2$  should also withstand large RMS values of currents, the expression is given by

$$C_2 \geq \frac{I_o D}{(\Delta V_{C2 \text{ ripple}}) 0.5 f_{sw}} \quad (9)$$

Table 1. Specifications of SEPIC converter

Sl.No.	Parameter	Specification
1	Input voltage, $V_{ac}$ (rms)	230V AC
2	$L_1, L_2$	2.8 mH ,1.4 mH
3	$C_1, C_2$	2200 $\mu F$ ,1000 $\mu F$
4	MOSFET , Diode, Rectifier Bridge	IRF430, FR306, MBR25
5	$f_{sw}$	100 kHz
6	Load	LED 18W
7	Output power ( $P_o$ ), W	18W
8	Output voltage, $V_o$	47 V
9	Output current, $I_o$	350mA

### 3. RESULTS AND ANALYSIS

The simulation for the peak current mode controlled SEPIC converter with LED as load is carried out using MATLAB/SIMULINK software tool. The input ac voltage and the input current waveforms in open loop and closed loop are shown in Figs. 2(a) and 2(b). It is clear that the input current is non sinusoidal and it introduces distortion which results in poor power factor at input AC mains. From the simulated waveforms of closed loop implementation, it is inferred that the input current is in phase with the supply voltage. Hence the power factor measured is almost unity. PCMC operation is implemented using a low cost commercial IC (UC3842) which is used as the controller for a SEPIC based led driver. A laboratory prototype to supply an 18W LED array from 230Vrms/50Hz is implemented to validate the simulation results.

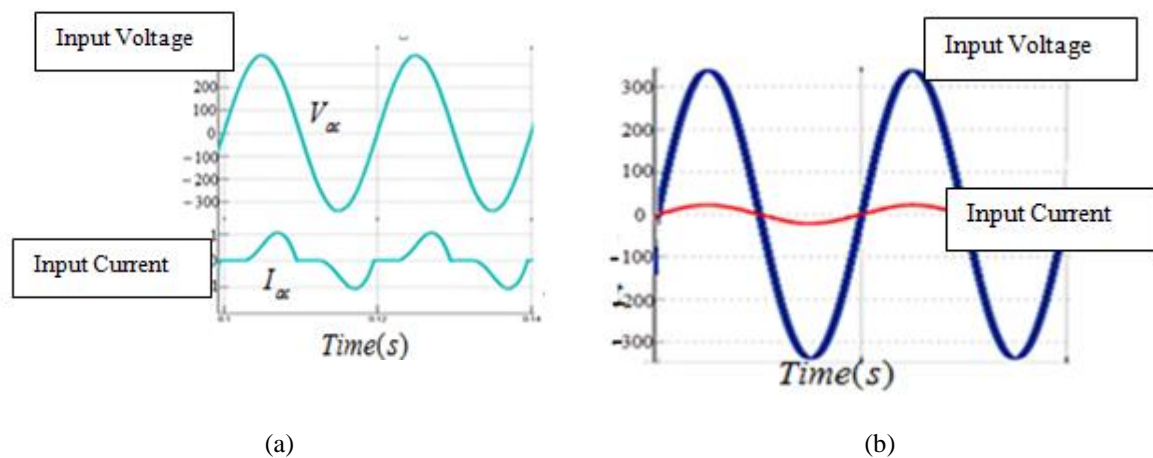

Figure 2. Simulated waveforms of (a) input voltage and input current in open loop (b) input voltage and input current in closed loop

The hardware implementation using IC 3842 is shown in Figure. 3 UC3842 is an integrated PWM IC. It consists of an oscillator, an error amplifier, pulse width modulator and a ramp generator with its reset. The ramp generator is built using discrete analog components namely  $R_T$  and  $C_T$ . The values of resistor,  $R_T$  and  $C_T$  have been chosen in order to generate an adequate compensation ramp. Shunt resistor of 300  $\Omega$  is connected with the current sense pin no. 3 of UC3842 as shown in Figure 3. A clock signal initiates power pulses at a fixed frequency. Each pulse is terminated when the inductor current reaches a reference value by the error signal. In this way, the error signal controls peak inductor current. This contrasts with conventional schemes in which the error signal directly controls pulse width without regard to inductor current.  $V_{dc}$  is sensed through pin no. 2 of UC3842 using a potential divider. The PWM output is generated at pin no. 6 of UC3842 which is provided to the gate of the MOSFET switch. The converter output is connected to a string of 18 white HBLEDs. Series connection allows the lamp LEDs to illuminate homogeneously, avoiding

brightness mismatches within the LED array. Furthermore, series-connected LED arrays need no equalization circuitry thus simplifying the lamp and reducing cost. IRF430 MOSFET is used as switching device for the SEPIC converter, FR306 Diode is used. The load consists of pure white LED's, which has a typical current of 350 mA and forward voltage of 3.0 to 3.5V.

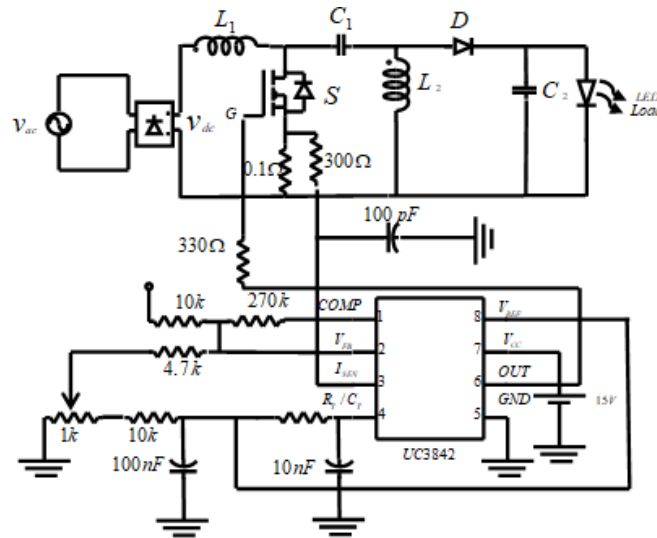

Figure. 3. Hardware implementation of HBLED driver using IC3842

The hardware results of input voltage and input current waveforms in open loop for SEPIC converter are shown in Figure 4 (a). It is inferred that the input current is non-sinusoidal which results in harmonic distortion of 35.5% and the power factor is 0.68 at the AC input. Figure 4 (b) shows that the ripple is present in the load current.

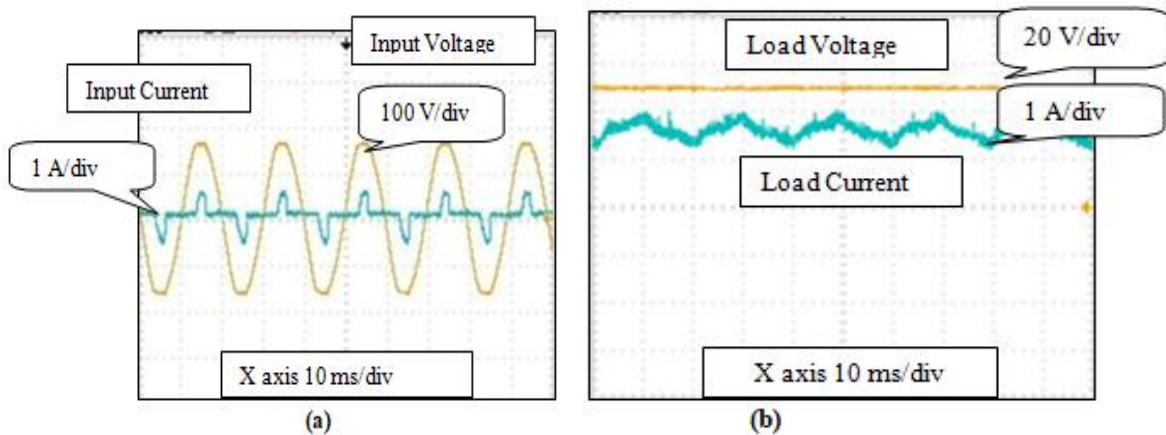

Figure 4. Experimental waveform of (a) input voltage and input current (b) load voltage and current in open loop

Figure 5(a) shows that the input voltage and input current waveforms of the SEPIC converter after employing PFC strategy experimentally. It is inferred that the input current is in phase with input voltage, the power factor measured is greater than 0.9. As can be seen in Figure 5(b), a significant ripple free output current appears; hence the efficiency of the circuit increases. Another important feature of the proposed control circuitry is its ability to operate at very high switching frequency. Several performance advantages results using PCMC technique. The control circuit instantaneously corrects for input voltage variations. Therefore, line regulation is excellent for load variations.

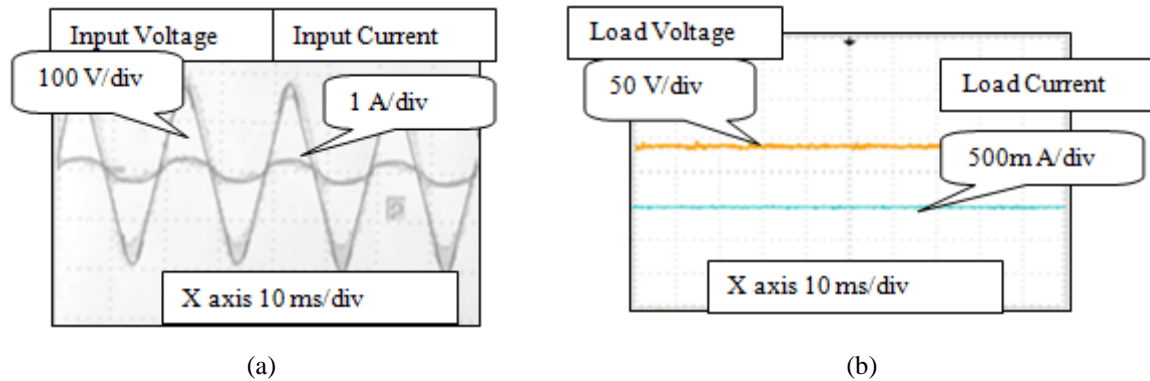

Figure 5. Experimental waveforms (a) input voltage and input current (b) load voltage and load current in closed loop

#### 4. CONCLUSION

An inexpensive HBLED driver using SEPIC PFC circuit has been presented in this paper. The PFC method is based on the use of a commercial PCMC IC UC3842. This PCMC SEPIC converter is operated in continuous conduction mode providing an input power factor nearing unity according to the standard requirements for lighting. The simulation and hardware results of the proposed LED driver have been presented in detail. The driver delivers a typical average current of 350 and can drive series connected LEDs with an efficiency of greater than 90%.

#### REFERENCES

- [1] L. Azevedo, M. G. Morgan and F. Morgan, "The Transition to Solid-State Lighting," in *Proceedings of the IEEE*, vol. 97, no. 3, pp. 481-510, March 2009.
- [2] M. S. Shur and R. Zukauskas, "Solid-State Lighting: Toward Superior Illumination," in *Proceedings of the IEEE*, vol. 93, no. 10, pp. 1691-1703, Oct. 2005.
- [3] H. M. Noor ul Huda Khan Asghar, Z. A. Gilani, M. S. Awan et al. "Characterization of InGaN by Means of I-V Measurements of Respective Light-Emitting Diode (LED) by DLTS", *Arab J Sci Eng* (2015).
- [4] H. J. Chiu, Y. K. Lo, J. T. Chen, S. J. Cheng, C. Y. Lin and S. C. Mou, "A High-Efficiency Dimmable LED Driver for Low-Power Lighting Applications," in *IEEE Transactions on Industrial Electronics*, vol. 57, no. 2, pp. 735-743, Feb. 2010.
- [5] M.M. Garg, Y.V. Hote, M .K. Pathak. "Design and Performance Analysis of a PWM dc-dc Buck Converter Using PI-Lead Compensator", *Arab J Sci Eng* (2015).
- [6] M. Gopinath, G. Gopu, "Closed Loop Analysis Of Bridgeless SEPIC Converter for Drive Application" *International Journal of Power Electronics and Drive System*, Vol. 6, No. 2, 2015, pp. 253-259.
- [7] R. Thenmozhi, C. Sharmeela ,P. Natarajan,R. Velraj, "Fuzzy Logic Controller based Bridgeless (BL) Isolated Interleaved Zeta Converter for LED Lamp Driver Application" *International Journal of Power Electronics and Drive System*, Vol. 7, No. 2, June 2016, pp. 509-520.
- [8] Z. Ye, F. Greenfeld and Z. Liang, "Single-Stage Offline SEPIC Converter with Power Factor Correction to Drive High Brightness LEDs," *2009 Twenty-Fourth Annual IEEE Applied Power Electronics Conference and Exposition*, Washington, DC, 2009, pp. 546-553.
- [9] H. M. Huang, S. H. Twu, S. J. Cheng and H. J. Chiu, "A Single-Stage SEPIC PFC Converter for Multiple Lighting LED Lamps," *4th IEEE International Symposium on Electronic Design, Test and Applications (delta 2008)*, Hong Kong, 2008, pp. 15-19.

- [10] Zhongming Ye, Fred Greenfeld and Zhixiang Liang, "Offline SEPIC converter to drive the high brightness white LED for lighting applications," *2008 34th Annual Conference of IEEE Industrial Electronics*, Orlando, FL, 2008, pp. 1994-2000.
- [11] J. M. Alonso, J. Vina, D. G. Vaquero, G. Martinez and R. Osorio, "Analysis and Design of the Integrated Double Buck–Boost Converter as a High-Power-Factor Driver for Power-LED Lamps," in *IEEE Transactions on Industrial Electronics*, vol. 59, no. 4, pp. 1689-1697, April 2012.
- [12] W. Chen and S. Y. R. Hui, "Elimination of an Electrolytic Capacitor in AC/DC Light-Emitting Diode (LED) Driver With High Input Power Factor and Constant Output Current," in *IEEE Transactions on Power Electronics*, vol. 27, no. 3, pp. 1598-1607, March 2012.
- [13] S. Amir, R. van der Zee and B. Nauta, "An Improved Modeling and Analysis Technique for Peak Current-Mode Control-Based Boost Converters," in *IEEE Transactions on Power Electronics*, vol. 30, no. 9, pp. 5309-5317, Sept. 2015.
- [14] D. G. Lamar, J. S. Ziga, A. R. Alonso, M. R. Gonzalez and M. M. Hernando lvarez, "A Very Simple Control Strategy for Power Factor Correctors Driving High-Brightness LEDs," in *IEEE Transactions on Power Electronics*, vol. 24, no. 8, pp. 2032-2042, Aug. 2009.
- [15] H. M. Huang, S. H. Twu, S. J. Cheng and H. J. Chiu, "A Single-Stage SEPIC PFC Converter for Multiple Lighting LED Lamps," *4th IEEE International Symposium on Electronic Design, Test and Applications (delta 2008)*, Hong Kong, 2008, pp. 15-19.
- [16] P. TianFu, C. HuangJen, C. ShihJen and C. ShihYen, "An Improved Single-Stage Flyback PFC Converter for High-Luminance Lighting LED Lamps," *2007 8th International Conference on Electronic Measurement and Instruments*, Xi'an, 2007, pp. 4-212-4-215.
- [17] J. P. Gegner and C. Q. Lee, "Linear peak current mode control: a simple active power factor correction control technique for continuous conduction mode," *PESC Record. 27th Annual IEEE Power Electronics Specialists Conference*, Baveno, 1996, pp. 196-202 vol.1.