

Investigation of the Experimental Characterization of the Different Inorganic Light Emitting Diodes (LEDS) and the Photovoltaic Effect on these LEDs

K. Remidi¹, A. Cheknane², M. Haddadi³

¹Department of Physics Ecole Normale Supérieure (ENS), Algeria

²Laboratory of Semiconductors and Functional Materials, Université Amar Telidji de Laghouat, Algeria

³Electrical Department National Polytechnic School or École Nationale Polytechnique (ENP), Algeria

Article Info

Article history:

Received May 22, 2018

Revised Jul 17, 2018

Accepted Aug 6, 2018

Keyword:

Light emitting diodes (LEDS)
ENP

ABSTRACT

This paper describes our experiments on the electrical characterization of commercial light emitting diodes of different colors as well as their photoelectric effect. This experiment was conducted at the IMS of Bordeaux, which has a measurement bench allowing the intrinsic characterization of different light-emitting diodes in direct and reverse polarization. This bench also makes it possible to compare these experimental values with the theoretical values obtained by modeling. A second work done at the ENP of El-Harrach allowed us to put in place measurement means to show that there is a photovoltaic effect on the LEDs. For this purpose, we have measured the electrical characteristics of different LEDs and studied their light intensities using an EPLEY pyranometer. This work involved red, green, yellow, white and blue LEDs. The photovoltaic behavior of light-emitting diodes (LEDs) was studied at ENP D'El Harrah Algeria, for a period of three days in March 2016. LEDs were exposed to solar radiation in the form of unitary units of LEDs. 9-16 hours These irradiated LEDs were monitored for photo-generated voltage and current at one-hour intervals. Solar radiation on a horizontal surface was measured using a Pyranometer.

Copyright © 2018 Institute of Advanced Engineering and Science.
All rights reserved.

Corresponding Author:

K. Remidi,
Département de Physique Ecole Normale Supérieure (ENS)
Kouba 16050 Alger Algérie.
Email: remidikam@gmail.com

1. INTRODUCTION

LEDs are now cost-effective light sources for general lighting and accent lighting. They can replace conventional light sources and thus improve flexibility and reduce power consumption. In 1962, the first red LED was created by Nick Holonyak Jr and S. Bevacqua. For several years, researchers have been limited to a few colors such as red (1962), yellow and blue (1972) [1, 2] or green. Conventional low power LEDs are an attractive alternative in comparison to conventional products such as fluorescent lights, incandescent or discharge. They offer such a great advantage which is low power consumption, long life time and the ability to select a very specific color among many others. High power white LEDs (over 1W) have been gaining momentum since the beginning of the 2000s for use in backlighting displays, car headlights and general lighting. On October 7, 2014, Shuji Nakamura, Isamu Akasaki and Hiroshi Amano received the Nobel Prize in Physics for their work on blue LEDs [9] [3]. Light-emitting diode (LED) is a semiconductor diode that gives light when forward biased. [4, 5] The radiation comes from the emission of a photon during the electron / hole recombination [6, 7]. In the general case, an LED must be connected to a voltage source via a current limiting resistor [5, 8]. LEDs are made of gallium arsenide (GaAs), gallium arsenide phosphide (GaAsP), or gallium phosphide (GaP). GaAs LEDs emit infrared (IR) radiation, GaAsP produces either red

or yellow visible light, and GaP emits red or green visible light. LEDs that emit blue light (such as tri-colour LEDs) are based on the wide band gap semiconductors such as gallium nitride (GaN) and indium gallium nitride (InGaN). The most popular solar cell material, silicon, has a less favourable band gap (1.1eV, maximum efficiency of 29%) but is cheap and abundant compared to these group III-V materials [9, 10]. The semiconductor material must be a direct band gap semiconductor in order to have sufficient conversion efficiency [11]. In contrast to solar cell, LED converts electrical power to visible light. The light output is due to the recombination of electrons and holes within the LED device, which releases energy in the form of photons. A solar cell is essentially a PN junction with large surface area while LED has only a small surface area. A few research works have been carried out on the effect of solar radiation on light-emitting diodes. One of the researchers was working on a low cost solar tracker and during his experiences with LEDs, he noticed that they generated voltage in sunlight.

Some work has been carried out since the 90s on the photovoltaic effect in LEDs but mainly on organic LEDs (in particular on poly [2-methoxy, 5-(2-ethylhexoxy)-1,4-phenylene vinylene]). This same effect can probably be observed in organic LEDs (OLEDs) according to the process described by Karzazi [12]. Other works concerned LEDs obtained by putting a thin layer of indium oxide over a surface of silicon P but of the porous type (Maruska, H. Paul, Energy bands in quantum confined silicon light-emitting diodes, [13]). Work on the photovoltaic effect in commercial LEDs does not appear to have been conducted systematically. It will be up to us to fill what we think is a gap. Therefore, one of the objectives of this research is to study the photovoltaic effect of light-emitting diodes (LEDs).

2. RESEARCH METHOD

The basic principle is to measure the variation of the current as a function of the voltage applied across a temperature-regulated LED. The component is included in the Cryostat with controlled liquid nitrogen circulation.

2.1. Characterization of Conventional LEDs of Different Colors

Bench block diagram is shown in Figure 1 [14]., temperature was controlled by the bench and the outside temperature of the LED assembly.

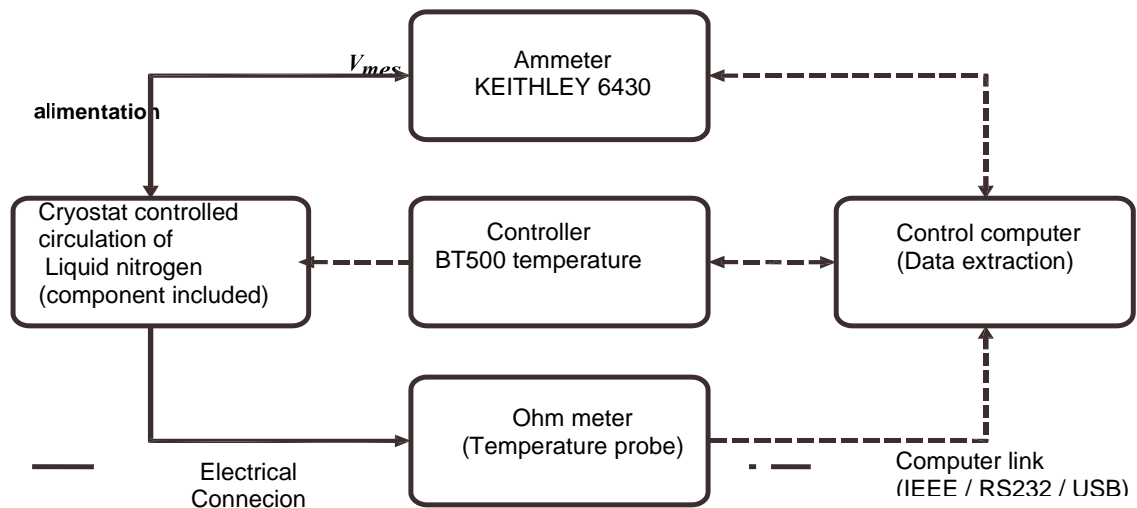

Figure 1. Schematic Diagram of the Bench $I=f(V)$

The equipment used consists of:

1. Analyzer semiconductor parameters KEITHLEY 6430 connected by an IEEE bus connected to the CPU of the control computer. This device consists of a current source (10-16 A to 0.1 A) 10-17 A resolution (error 0.1%) and a voltage source (0 to 10 V) resolution 10-6 V (error 0.1%);
2. Liquid nitrogen flow cryostat LN2 is controlled where in the component. It allows temperature regulation in a range of 80 K to 350 K with a precision of 0.1 K;

3. Temperature control unit (Temperature Controller BT 500) used for temperature regulation during measurements. It controls the heating resistor of the cryostat using a PID automatic system (Proportional Integral Derivative);
4. Drypump (ADIXEN) whose role is to conduct a primary vacuum (1: -2 Torr) in the vacuum chamber of the cryostat;
5. Ohmmeter giving a resistance value denoted R_{sonde} , corresponding to the value of the resistance of the PT100 heat sensor. This probe provides access to the TP package temperature of the LED;
6. To overcome the resistance of electrical cables, the LED is connected in measure 4 son with Triaxcables (Keithley) [15, 16].

2.2. PV Different LED Effect

Different LED colors (red, green, yellow, white, blue) were obtained locally from a component store. These were arranged separately to stand on a breadboard. This configuration was kept outdoors in a sunny area and

We do not know any work where the LEDs were built and radiated by the sunlight. Therefore, one of the objectives of this research is to study the photovoltaic behavior of light-emitting diodes (LEDs). The measuring device is based on a pyranometer device which measures the luminance in W / m^2 and which is disposed in the same plane as the LED under test. We choose the correct orientation of the LED for maximum current flow at its terminals. Several measures will be taken (twenty) one day. The coefficient of the pyranometer is:

$$C = 9,56 \times 10^{-6} V / (W / m^2)$$

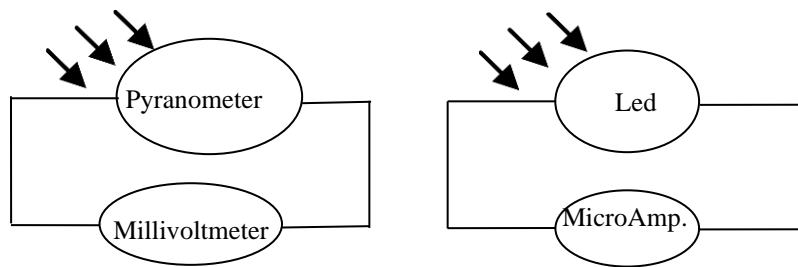

Figure 2. Diagram of the Light Measuring Device According to the Current of the LED $V_p=f(I_d)$

The photovoltaic effect of light-emitting diodes (LEDs) experience was realized at ENP El Harrach Algeria, for a period of three days March 2016. The LEDs were exposed to solar radiation as single units of LEDs connected, from 9–16hours these irradiated LEDs were monitored for photo-generated voltage and current at hourly intervals. The solar radiation on a horizontal surface was measured using pyranometer $500w/m^2$. In $25^\circ c$ temperature was measured using mercury-in-glass thermometer while the photo-generated voltage and current were monitored using a standard digital multimeter.

3. RESULTS AND ANALYSIS

3.1. Current Voltage Characteristic of a Classic Red, Yellow, Green, White and Blue LED

The current-voltage characteristic of a conventional LED is given in Figure 4. The first drawn in linear scale shows a threshold voltage V_s between two main areas: B where the diode is conducting ($V > V_s$) and where A diode is blocked ($V < V_s$). The behavior is the one of a diode. This plot is ideal for high injection levels ($V > V_s$). Those characteristics $I(V)$ characteristic of a red LED, yellow, green, white and blue is shown in Figures 3 and 4.

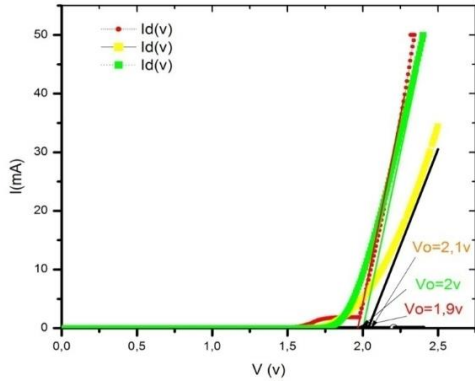

Figure 3. Characteristic $I_d = f(V)$ a Red; a Green ;Yellow LED, in Direct

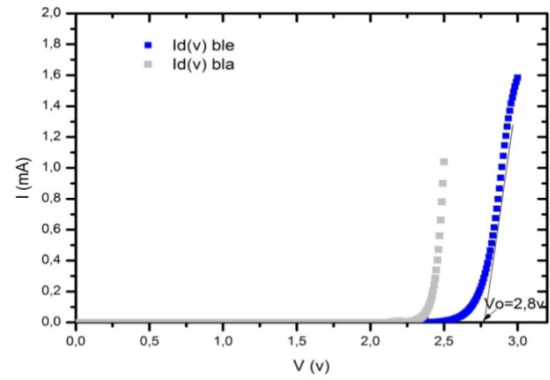

Figure 4. Characteristic $I = f(V)$ a White and a Blue LED in Direct

Table 1.

leds	blue	white	yellow	green	red
$V_0(v)$	2.8	2.4	2.1	2	1.9

The results in Table 1 indicate that the blue LED has produced the highest threshold voltage V_0 the blue of 2.8V then the 2.4V cubicle after the 2.1V yellow; 1 the green 2V the last the weakest 1.9 red V

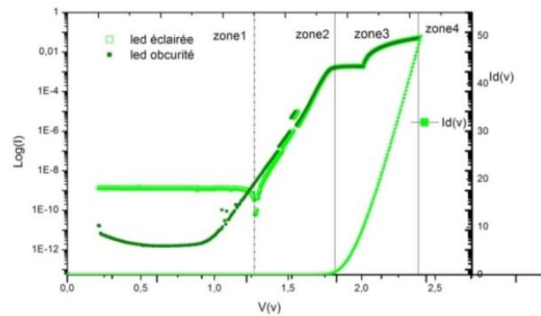

Figure.5: Characteristic $\log I_i = f(V)$ a green LED, in inverse

The second figure $\log I (V)$, complementary to the firestone four distinct current injection regions: posse we choosed the green led Characteristic $\log I_i$ to represent

The second figure $\log I (V)$, complementary to the firestone possesses four distinct current injection regions:

- * Very low injection level (Zone I): $I \leq 1 \text{ nA}$;
- * Low level of injection (Zone II): $1 \text{ nA} \leq I \leq 1 \text{ mA}$;
- * Middle injection level (Zone III): $1 \text{ mA} \leq I \leq 100 \text{ mA}$;
- * Fort injection level (Zone IV): $I \geq 100 \text{ mA}$.

This plot is very well suited to low injection levels ($V < V_s$). It should noted that the development of the models will follow the $I (V)$ or $\log I (V)$ route, a green LED has been chosen, depending on the injection levels. The purpose of this section is to recall the well-known analytical model of transport phenomena in the four areas of operation.

3.2. Power of a Classic Red, Green, Yellow and Blue Del Models

Photovoltaic effect of different LED:

$C = 9, 56 \times 10^{-6} \text{V} / (\text{W} / \text{m}^2)$ this coefficient allows us to transform the voltage (v) across the pyranometer in light intensity (W / m^2) Table light intensity depending on the current through the various LEDs.

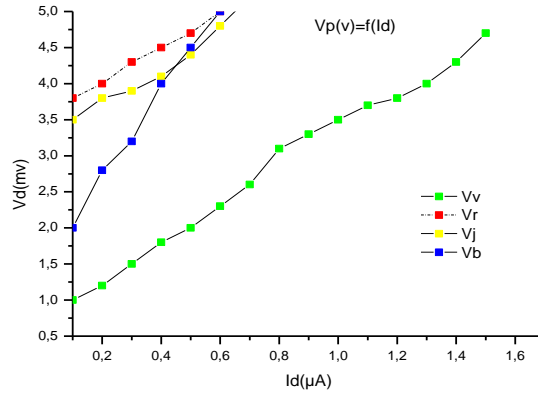

Figure 6. Voltage of the Pyranometer in Volts According to the Current of the LEDs

The results obtained show that voltage and current increased with the intensity of solar radiation, with maximum values recorded between 1hours-16hours. The series-connected simples commercial LEDs yielded a voltage of 5mV and a current of 1.5µA.

We notice that there is a proportionality between the current of the led I_d te the voltage at the terminals of the Pyranometer V_p .

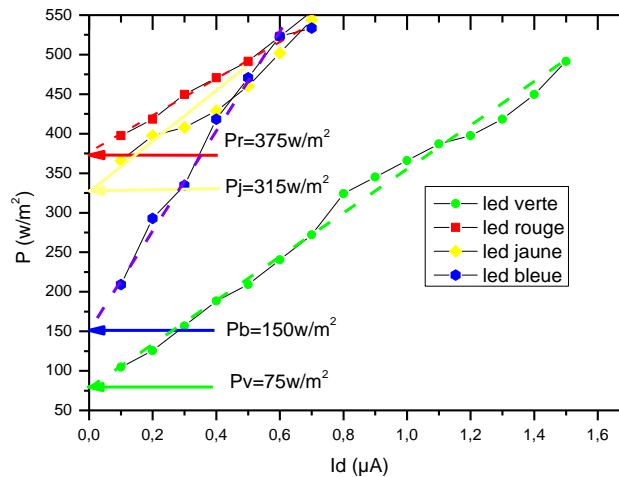

Figure 6. Light Power (W/m2) According to the Current I_d (uA)

This graph shows a photovoltaic effect of these LEDs and we see that the green LED (75 w/m2) is more sensitive than the blue (150w/m2);yellow (315 w/m2)) and the red (375 w/m2)) which is the least sensitive and that the curve is linear for all the led's $P=Aid+b$ with slope of the graph and b: light power when the current $I=0$

4. CONCLUSION

This article reports two different results on commercial LED components and their photovoltaic effect. Characterization of LEDs in reverse has allowed us to highlight the feasibility of using LEDs as a photo detector. The induced photo current is of the order of 1 nA

The results obtained will validate our hypotheses, already established, they will also allow to appreciate the potentialities of the LED in the photovoltaic field and to examine the niches in which they would probably be integrated. This second work made it possible to set up measurement means to show that

there is a photovoltaic effect on the LEDs of the ENP "El Harrah" (polytechnic school of Algiers). For this, we studied their light intensities using an EPLEY pyranometer.

The study of the behavior of the different colored LEDs vis-à-vis solar radiation has been successfully conducted. The results showed that the red LED has a luminous intensity of (375w / m²), yellow (315w / m²), blue (150w / m²) and green (75w / m²).

REFERENCES

- [1] Neel V. Patel: "Nobel Shocker: RCA Had the First Blue LED in 1972"; 7 oct2014
- [2] C. Noah Photobiomodulation dermatology: Understanding and using LED, John Libbey Eurotext - Doin, coll. "Lasers and related technologies," 2014
- [3] <https://www.futura-sciences.com/physique-nobel-physique-2014-eclairage-led-reco> « The Nobel Prize in Physics 2014 » [archive], sur Site officiel du prix Nobel, 7 octobre 2014 .
- [4] V.K. Mehta, R. Mehta. Principles of Electronics, S.Chand & Company Ltd, India, 181 – 182 (1980)
- [5] T.L. Floyd. Electronic Devices, Pearson Education Inc, India. 135, (2002).
- [6] Light-emitting diode, http://en.wikipedia.org/wiki/light-emitting_diode, Retrieved 2010-04
- [7] ToolBase Services LED Lighting, (2008). <http://www.toolbase.org/TechnologyInventory>, Retrieved 2010-04-13
- [8] W. Shockley, H.J. Queisser. "Detailed balance limit of efficiency of p-n junction solar cells", J. Appl. Phys. 32, 510-519, (1961).
- [9] J. Nelson. Physics of Solar Cells, Imperial College Press London, 177, (2003).
- [10] C.H. Henry. "Limiting efficiencies of ideal single and multiple energy gap terrestrial solar cells", J. Appl. Phys. 51, 4494-4499, (1980).
- [11] Direct and Indirect Band Gap semiconductor, http://wikipedia.org/wiki/Direct_and_indirectbandgap, Retrieved 2010-04-13
- [12] Karzazi Y., Organic Light Emitting Diodes: Devices and Applications, J. Mater. Env. Sci. 5 (1) (2014) 1-12.
- [13] Applied Physics Letters, Volume: 63, Issue: 1, Jul 93).
- [14] Raphaël Baillot ;Thesis presented by the university of bordeaux doctoralphysical science and engineering
- [15] J J. Singleton, "Band theory and electronic properties of solids" ; Oxford University Press, 2001.
- [16] J. R. Barnes, "Robust electronic design reference book vol. 1" Springer, 2004