

# A comparative study of cascade h-bridge multilevel voltage source inverter and parallel inductor multilevel current source inverter

Nik Fasdi Nik Ismail, Norazlan Hashim, Dalina Johari

Faculty of Electrical Engineering, Universiti of Teknologi Mara (UiTM), Malaysia

---

## Article Info

### Article history:

Received Sep 24, 2018

Revised Jan 19, 2019

Accepted Mar 9, 2019

---

### Keywords:

Multilevel current source inverter (MCSI)

Multilevel voltage source inverters (MVSI)

Sinusoidal pulse width modulation (SPWM)

Total harmonic distortion (THD)

---

## ABSTRACT

This paper presents the analysis study between multilevel inverters that are often classified into multilevel voltage source and multilevel current source inverters. For multilevel voltage source inverter (MVSI), the specific topology studied for this work is the Cascaded H-Bridge MVSI. Whereas, the multilevel current source inverter (MCSI) is based on Paralleled Inductor Configuration MCSI. For this study, the analysis between these converters are done with respect to the number of components, the advantages and disadvantages of each converters during performing inverter operation. In term of output voltage and current quality, the percentage of the Total Harmonic Distortion (THD) are measured and compared for both topologies. MATLAB/Simulink software has been used in this research to design and simulate in order to study the performances of both inverters.

Copyright © 2019 Institute of Advanced Engineering and Science.  
All rights reserved.

---

### Corresponding Author:

Nik Fasdi Nik Ismail,  
Departement of Electrical Engineering,  
University Teknologi Mara (UiTM),  
Shah Alam, Selangor, Malaysia.  
Email: nikfasdi@yahoo.com

---

## 1. INTRODUCTION

The Inverter has been the number one choice to be used in the industry for many years out of all power electronic devices in order to convert dc to ac power at the desired frequency and output voltage. For applications that uses high voltage and power, conventional inverter has commonly been used. It operates at high rating constraints with high switching frequency and high switching losses which makes it popular to be used among industrial users. Besides facing the EMI, harmonic distortion and high stress, the most common problem of any inverters are the total harmonic distortion (THD) at the output voltage and current [1-3]. These problems caused difficulties for the power electronic devices to be interfaced directly to the medium or high voltage grid. Therefore, different topologies of the multilevel inverters were introduced to overcome these problems. By employing the Multilevel inverters, several AC output voltage and current levels can be obtained with sinusoidal waveforms which have low THD levels at the output voltage and current [4-7].

Multilevel inverters have been widely used in industrial applications for high ranges of voltage and power [8-11]. Some of the advantages of using the multilevel inverters are the increase of voltage and current levels with staircase waveforms, the reductions of total harmonic distortions THD, systems are able to operate at fundamental and high switching frequency, high power quality, lower switching losses and etc [12-14]. Meanwhile, the disadvantage would be that multilevel inverters require high number of power electronic switches. Thus, with high number of components, it would cause the overall system to be expensive, complex and sometimes, unpractical to be realized [15, 16]. Multilevel Voltage Source Inverter

(MVSI) and Multilevel Current Source Inverter (MCSI) are the two well-known multilevel converters that have different topologies besides having the same working principles [17-19]. Thus, MCSI can use the same power semiconductor devices used for MVSI with some modifications [2, 4]. The input current of the multilevel current source inverter is kept constant meanwhile the output current is independent of the load changes. Unlike MVSI, MCSI does not require any feedback diode and the commutation circuit is much simpler with short circuit operation. However, majority of the worldwide prefers to install the voltage source inverter (VSI) followed by current source inverters (CSI). VSI has been dominating the industrial market which results in the limitations of research on multi-level current source inverters [20-23]. The main reason for the lack of interest on MCSI is the bulky DC link inductor size as compare to VSI with a smaller static DC link capacitor. However, it is known that MCSI has better performance compare to MVSI especially in the medium-voltage drive applications such as simple converter structures, low switch count, and reliable over-current/short-circuit protection [12, 21]. For this research, the specific topology studied for the MVSI is the Cascaded H-Bridge Converter. Meanwhile, the MCSI focuses on the Paralleled Inductor Converter. Both Multilevel Inverters have their own advantages and disadvantages. Thus, the aim of this study is to compare the two topologies and to explore the performance of the two multilevel topologies. MATLAB/Simulink software has been used as a simulation software to analyze and make the comparison between the two topologies namely Cascaded H-Bridge MVSI and Paralleled Inductor Configuration MCSI.

## 2. RESEARCH METHOD

### 2.1. Cascade H-Bridge Multilevel Voltage Source

Voltage Source Inverter (VSI) is one of the types of DC/AC Converters that is commonly used in the industrial applications and has been studied extensively. This particular converter is divided into three which are the Half-Bridge, Full Bridge and Multilevel Inverter [24]. There are five types of Multilevel Inverter (MVSI) consisting of the Neutral-Point Clamped Inverter, Flying Capacitor Inverter, Cascaded H-Bridge Inverter, and two other inverters that have not been studied extensively like the other three inverters namely the Hexagram Inverter and Hybrid Inverter. For this research, the specific topology studied representing the Multilevel Voltage Source Inverter (MVSI) is the Cascaded H-Bridge Inverter. Figure 1 and Table 1 show the five-level Cascaded H-Bridge topology and switching sequences respectively. For this circuit configuration, the output voltage consists of five-level output load voltage waveform.

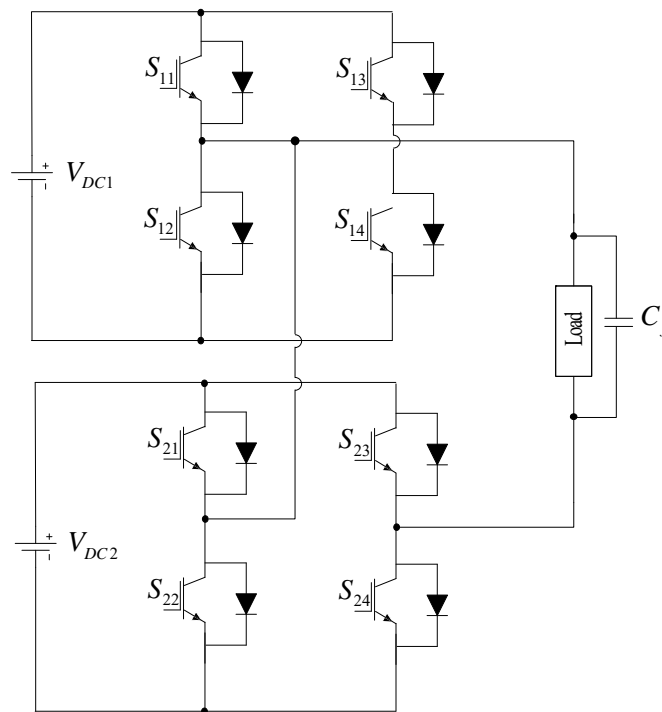

Figure 1. Cascaded h-bridge topology

Table 1. Switching state for 5-level cascaded h-bridge MVSI

Output Voltage, $V_o$	Switches							
	$S_{11}$	$S_{12}$	$S_{13}$	$S_{14}$	$S_{21}$	$S_{22}$	$S_{23}$	$S_{24}$
Vdc	1	0	0	1	1	0	0	1
Vdc/2	1	0	0	1	0	0	0	0
0	0	0	0	0	0	0	0	0
-Vdc/2	0	1	1	0	0	0	0	0
-Vdc	0	1	1	0	0	1	1	0

**2.2. Parallel inductor multilevel current source inverter**

For the CSI inverters, it can be divided into three main topologies, namely Pulsewidth-Modulated Inverter, Load-Commutated Inverter and Multilevel Inverter. There are three types of Multilevel Inverter for CSI and can be classified into Embedded Multilevel Inverter, Two-Stage Multilevel Inverter and the Paralleled Inductor Multilevel Inverter. These multilevel inverter are commonly used in motor drives and recommended to be used in the system that requires boosting capabilities such as in Fuel Cell power conditioning sytem and grid connected system. For this work, the specific topology chosen to representing the Multilevel Current Source Inverter (MCSI) is the Paralleled Inductor Configuration Inverter [7]. Figure 2 shows the five-level Parallel Inductor MCSI configuration topology. The switching sequence for this topology is given in Table 2.

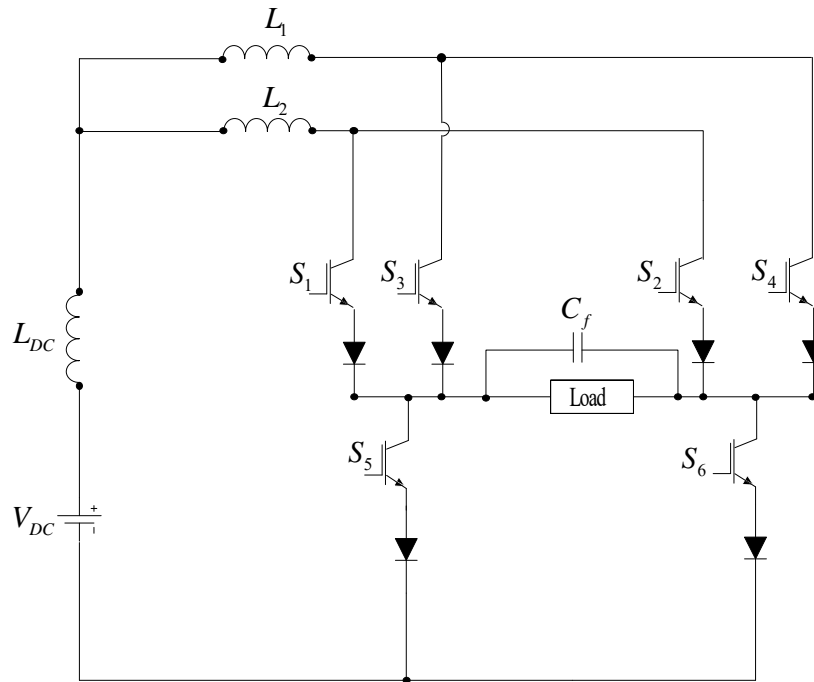

Figure 2. Cascaded h-bridge topology

Table 2. Switching state for five-level parallel inductor MCSI

$I_o$	$(S_1 S_2 S_3 S_4 S_5 S_6)$	No. States
$+I_{DC}$	(1,0,1,0,0,1)	1
$+\frac{I_{DC}}{2}$	(1,0,0,1,0,1),(0,1,1,0,0,1)	2
0	(1,0,1,0,1,0),(0,1,0,1,0,1)	2
$-\frac{I_{DC}}{2}$	(0,1,1,0,1,0)(1,0,0,1,1,0)	2
$-I_{DC}$	(0,1,0,1,1,0)	1

### 2.3. SPWM for multilevel voltage source and current source inverters

In order to control the gate signals of power switches for the MVSI and MCSI, a Phase Disposition (PD) SPWM methods is employed in the generation of gating signals for the power switches [25]. This PD-PWM methods is also able to reduce the Total Harmonic Distortion (THD) generated at the inverter output stage for the voltage and current. In a PD-SPWM scheme, 4 triangular carrier signals are compared with the single sine waveform signal in order to generate gating signals for each power switches in the circuits as shown in Figure 3. The PD-SPWM is widely used in MVSI and MCSI because it provides low THD for load voltage and current.

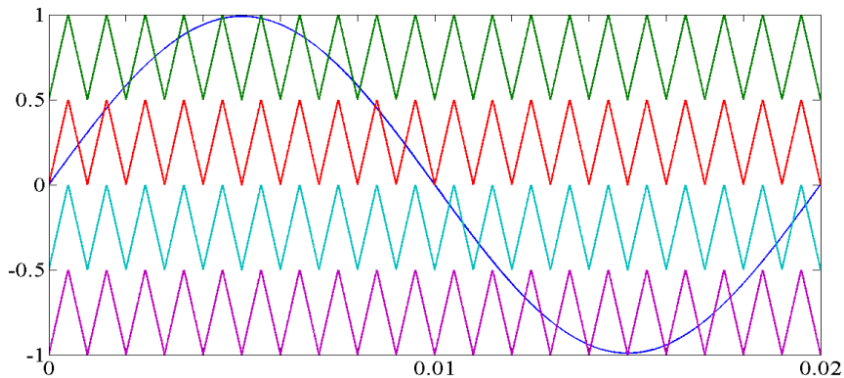

Figure 3. Phase disposition (PD) SPWM

## 3. RESULTS AND DISCUSSION

### 3.1. Total harmonic distortion analysis for MVSI and MCSI

Figures 4 and 5 show the THD analysis with matlab Simulink results for the five-level Cascaded H-Bridge MVSI. Whereas Figures 6 and 7 show the THD analysis for five-level Paralel inductor MCSI topologies. In Figure 8 to 9 and Figure 10 to 11 show the output voltage and current waveforms for Cascade H-Bridge MVSI and Parallel Inductor MCSI respectively. Table 3 lists the comparison of the THD analysis for both topologies for unfilter and filter output voltages and currents.

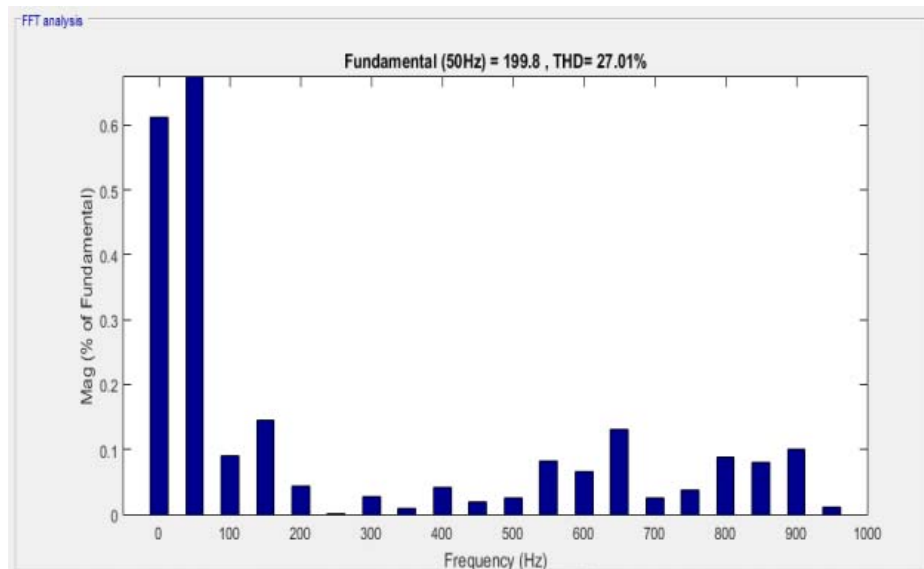

Figure 4. THD output voltage for 5-level cascaded h-bridge MVSI (Unfilter)

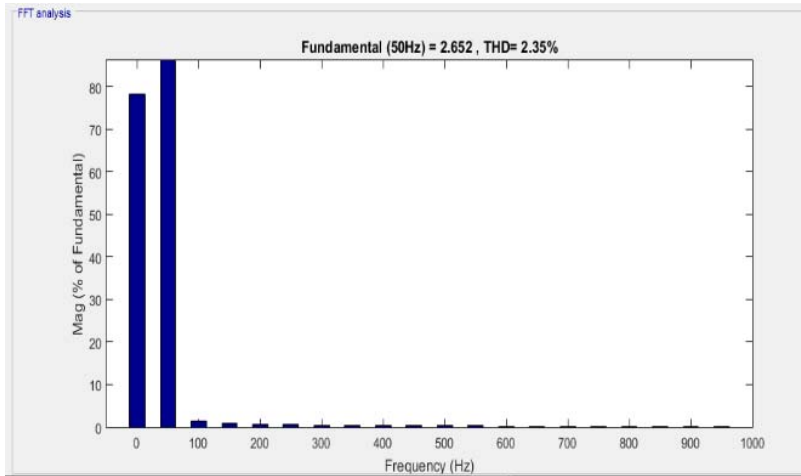

Figure 5. THD output voltage for 5-level cascaded h-bridge mvsii (filter)

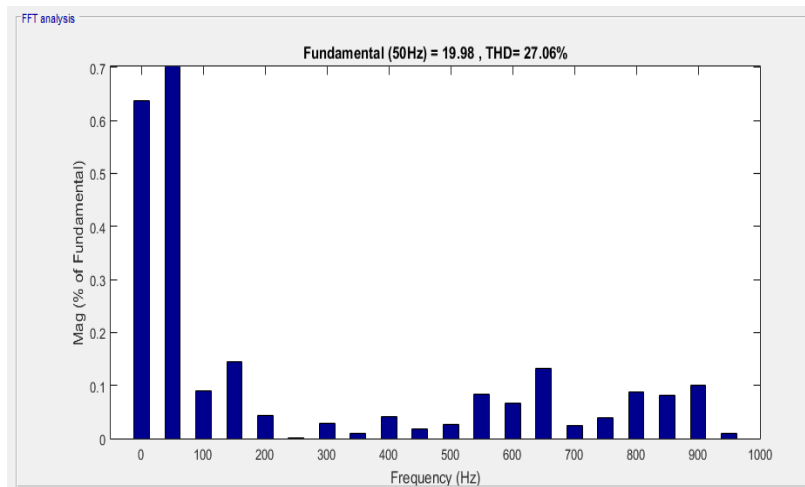

Figure 6. THD output voltage for 5-level parallel inductor mcsi (unfilter)

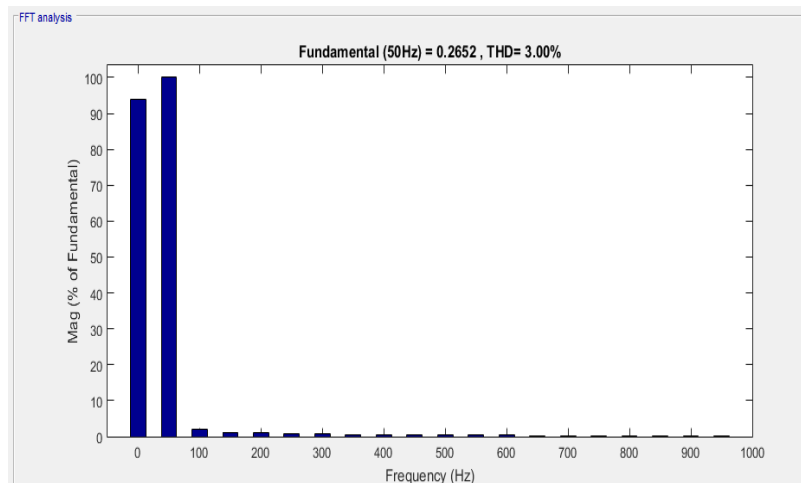

Figure 7. THD output voltage for 5-level parallel inductor mcsi (filter)

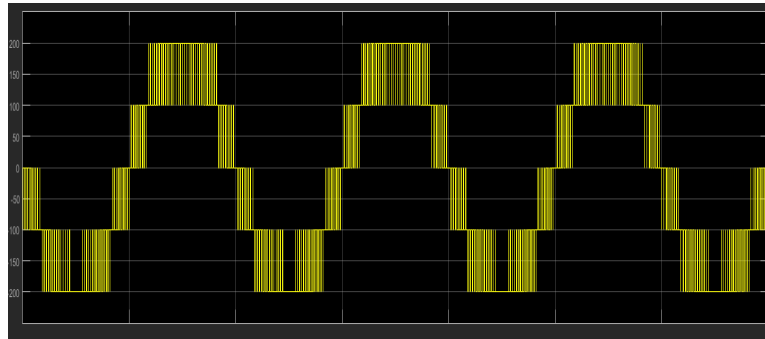

Figure 8. 5- level output load voltage for cascade h-bridge MVSI

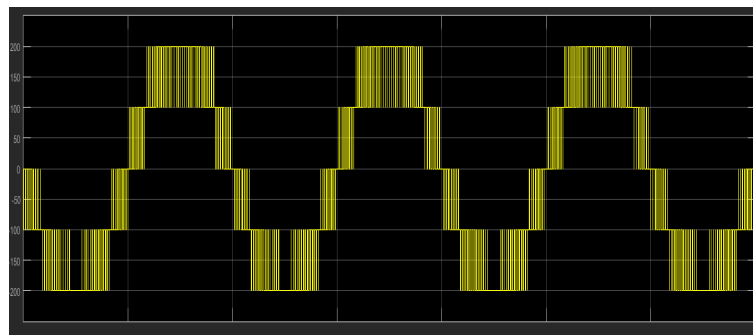

Figure 9. 5- level output load current for cascade h-bridge MVSI

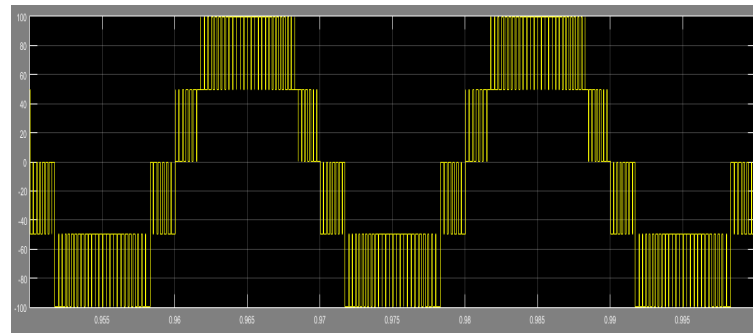

Figure 10. 5- level output load voltage for parallel inductor MCSI

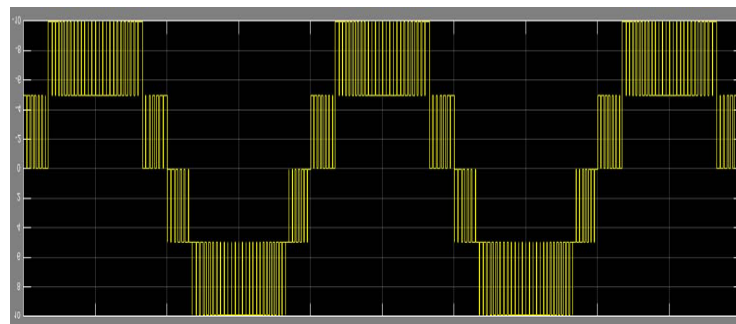

Figure 11. 5-level output load current for parallel inducor MCSI

Table 3. Comparison of THD for MVSI and MCSI

	Voltage		Current	
	Without Filter	With Filter	Without Filter	With Filter
MVSI	27.01%	2.35%	27.01%	2.35%
MCSI	27.06%	3.00%	27.06%	3.00%

From the analysis in Table 3, it shows that the MVSI after filtering gives better results for both output voltage and current which are 0.65% less than MCSI. This analysis shows that, MVSI perform better than MCSI in term of THD which indicates that the output waveforms for voltage and current generated in MVSI are more sinusoidal compare to output voltage and current generated in MCSI. The effect of this results is smaller output filter can be used in MVSI compare to MCSI. In a Cascade H-Bridge MVSI, the balancing of intermediate level is not an issues for this topology because the employment of separate DC sources. However in Parallel Inductor topology, two identical parallel inductor are used to split the DC current into intermediate level at the output load current. As a result, the imbalance of the intermediate level may exist at the output of voltage and current for MCSI. This can be seen from the analysis results listed in Table 3, where the MVSI has better performance compare to MCSI. Nevertheless, the Cascade H-Bridge MVSI employs two separate DC sources for the operation and from the complexity and cost point of view this become disadvantages for this topology. The number of power switches and double DC source for MVSI, added additional cost of the inverter.

### 3.2. The number of circuit components

The number of components between the discussed H-Bridge MVSI and Parallel Inductor MVSI for the 5-level are summarized in Table 4.

Table 4. Comparison of number of components in MVSI and MCSI

Components	Topology	
	Cascaded H-Bridge MVSI	Paralleled Inductor Configuration MCSI
DC Voltage Source	2	1
Switches	8	6
Resistors	1	1
Inductors	0	2
Diodes	0	6
TOTAL	11	16

From Table 4, it can be seen that, the Cascaded H-Bridge MVSI utilizes less number of passive and active components compare to Paralleled Inductor MCSI. However, as a forementioned, the separate DC sources for Cascade H-Bridge MVSI can limit the advantage of this inverter compare to MCSI. Because of employment of multiple DC sources, this topology can be unpractical to be realized to higher output level such as 7-level and 9 –level output load voltage.

## 4. CONCLUSION

This paper presents the comparative and analysis study of voltage and current multilevel inverters in term of output THD and the number of components employed in the circuits. From the analysis, Total Harmonic Distortion (THD) for Cascaded H-Bridge MVSI is better compared to the Paralleled Inductor MCSI. The number of components used in the 5-level Cascade H-Bridge MVSI are also gives the advantages of this inverter over the Parallel Inductor MCSI. However, the limitation for this topology is the used of multiple DC source to generate the multiple of output voltage and current. This can makes this topology becomes unpractical to be realize at higher output level.

## ACKNOWLEDGEMENTS

The authors appreciate financial support by the Institute of Research Management and Innovation (IRMI), UiTM Shah Alam, Selangor, Malaysia under LESTARI Research Grant Scheme with project code 600-RMI/DANA/5/3/LESTARI (0022/2016).

## REFERENCES

- [1] R Anjali Krishna and L Padma Krishna. "Brief Review on Multi Level Inverter Topologies". *International Conference on Circuit, Power and Computing Technologies*. IEEE. Mar, 2016.
- [2] B. ZhiHong and Z. ZhongChao, "Conformation of Multilevel Current Source Converter Topologies Using the Duality Principle," *Power Electronics, IEEE Transactions on*, vol. 23, pp. 2260-2267, 2008.
- [3] Balasubramanian, R., P. Kathirvelu, Shashwat and S. Palani, "Synchronous rotating reference frame based control technique for three-phase hybrid active power filter: A simulink approach," *J. Applied Sci.*, vol. 14, pp. 1557-1563, 2014.
- [4] Arthishri, K., R. Balasubramanian, P. Kathirvelu, S.P. Simon and R. Amirtharajan, "Maximum power point tracking of photovoltaic generation system using artificial neural network with improved tracking factor," *J. Applied Sci.*, vol. 14, pp. 1858-1864, 2014.
- [5] Ramezani, B., "Speed control simulation for induction motor by multi level VSI-Fed to analyse current harmonics and selective harmonics elimination," *J. Applied Sci.*, vol. 10, pp. 688-693, 2010.
- [6] M. R. Banaei, M. R. Jannati Oskuee and H. Khounjahan, "Reconfiguration of semi-cascaded multilevel inverter to improve systems performance parameters," *IET Power Electron.*, vol. 7, no. 5, pp. 1106-1112, 2014.
- [7] N.F. Nik Ismail, N.A.Rahim, S.R Sheikh Raihan, and Y. Al-Turki, "Parallel Inductor Multilevel Current Source Inverter with Energy Recovery Scheme For Inductor Current Balancing," *IET Power Electron*, vol. 9, no. 11, pp 2298-304, Sept, 2016
- [8] M. R. Banaei, M. R. Jannati Oskuee and F. Mohajel Kazemi, "Series H-bridge with stacked multi-cell inverter to quadruplicate voltage levels," *IET Power Electron.*, vol. 6, no. 5, pp. 878-884, 2013.
- [9] M. R. Banaei, F. Mohajel Kazemi, M. R. Jannati Oskuee, "New mixture of hybrid stacked multi-cell with half cascaded converter to increase voltage level," *IET Power Electron.*, vol. 6, no. 7, pp. 1406-1414, 2013.
- [10] A. Ajami, M. R. Jannati Oskuee, A. Mokhberdoran, H. Shokri, "Selective harmonic elimination method for wide range of modulation indexes in multilevel inverters using ICA," *J. Cent. South Univ.*, vol. 21, no. 4, pp. 1329-1338, 2014.
- [11] R. T. H. Li, H. S. Chung, and T. K. M. Chan, "An active modulation technique for single-phase grid connected CSI," *IEEE Trans. Power Electron.*, vol. 22, no. 4, pp. 1373-1380, 2007.
- [12] Ritesh dasu, Sarat Chandra swain and Sanhita mishra, "Comparative analysis of linear controllers used for grid connected PV system," in *International journal of electrical and computer engineering (IJECE)*, vol. 8, no. 1, pp 513-520, Feb 2018.
- [13] Sumaiya rahman and Hasima abdul rahman, "Use of photo voltaics in micro grid as energy source and control method using MATLAB/simulink," in *International journal of electrical and computer engineering (IJECE)*, vol. 6, no. 2, pp.851-858, apr 2016.
- [14] Lipika Nanda, A Dasgupta, U. K. Rout, "A comparative Analysis of Symmetrical and Asymmetrical Cascaded Multilevel Inverter Having Reduced Number of Switches and DC Sources," *International Journal of Power Electronics and Drive System (IJPEDS)*, vol. 8, no. 4, pp. 1595-1602, Dec 2017"
- [15] A. Nami, L. Jiaqi, F. Dijkhuizen, and G. D. Demetriades, "Modular Multilevel Converters for HVDC Applications: Review on converter cells and functionalities," *IEEE Trans. Power Electron.*, vol. 30, no. 1, pp. 18-36, 2015.
- [16] A. Ajami, M. R. Jannati Oskuee, M. T. Khosroshahi and A. Mokhberdoran, "Cascade multi-cell multilevel converter with reduced number of switches," *IET Power Electron.*, vol. 7, no. 3, pp. 552-558, 2014.
- [17] Suroso, Abdullah Nur Aziz, Toshihiko Noguchi "Five-level PWM Inverter with a Single DC Power Source for DC-AC Power Conversion," *International Journal of Power Electronics and Drive System (IJPEDS)*, vol. 8, no. 3, pp. 1230-1237, Sep 2017.
- [18] Thiagarajan V, Somasundaram P "A New Seven Level Symmetrical Inverter with Reduced Switch Count," *International Journal of Power Electronics and Drive System (IJPEDS)*, vol. 9, no. 2, pp. 921-925, Jun 2018.
- [19] Aparna Prayag, Sanjay Bodkhe "Novel Symmetric and Asymmetric Multilevel Inverter Topology for Permanent Magnet Synchronous Motor," *International Journal of Power Electronics and Drive System (IJPEDS)*, vol. 8, no. 3, pp. 1002-1010, Sep 2017.
- [20] M. A. Abdourraziq and M. Maaroufi, "Experimental verification of the main MPPT techniques for photovoltaic system," *International Journal of Power Electronics and Drive Systems (IJPEDS)* , vol. 8, no. 1, pp. 384-391, 2017.
- [21] M. Abdur Razzak, et al., "Design of a Grid-connected Photovoltaic Inverter with Maximum Power Point Tracking using Perturb and Observe Technique," *International Journal of Power Electronics and Drive System (IJPEDS)*, vol. 7, no. 4, pp. 1212-1220, Dec 2016.
- [22] Muhammad T, et al, "Cascaded Symmetric Multilevel Inverter with Reduced Number of Controlled Switches," *International Journal of Power Electronics and Drive System (IJPEDS)*, vol. 8, no. 2, pp. 795- 803, Jun 2017.
- [23] Ali A. Abdulrazzaq, Adnan H. Ali, "Efficiency Performances of Two MPPT Algorithms for PV System With Different Solar Panels Irradiances," *International Journal of Power Electronics and Drive System (IJPEDS)*, vol. 9, no. 4, pp. 1755-1764, Dec 2018.
- [24] Zulkefle A, et al, "Modeling and Simulation of Nine-Level Cascaded H-Bridge Multilevel Inverter," *Indonesian Journal of Electrical Engineering and Computer Science (IJECS)*, vol. 11, no. 2, pp. 696- 703, Aug 2018.
- [25] Manju aggarwal, Madhusudan singh and S.K.Gupta, "Fault ride through capability of DSTATCOM for distributed wind generation system," in *International Journal of Power Electronics And Drive Systemsmn (IJPEDS)*, vol. 6, no. 2, pp. 348-355, jun 2015.



**BIOGRAPHIES OF AUTHORS**

Nik Fasdi Nik Ismail was born in Kelantan, Malaysia, in 1978. He received the B.Sc. (Hons.) in 2002 in TokyoDenkiUniversity, Japan and M.Sc. degrees from the University of Malaya (UM), Malaysia, in 2008, respectively. He is a senior lecturer with the University of Teknologi Mara (UiTM), Malaysia. His research interest includes electric energy, high power dc/dc converter and fuel cell application.



D. Johari received her Ph. D degree in Lightning Physics from Uppsala University, Sweden in 2017. She obtained her MSc and Bachelor degrees in Electrical Engineering from Universiti Teknologi MARA (UiTM), Malaysia in 2008 and the University of Liverpool, UK in 1999, respectively. She currently works as a Senior Lecturer at UiTM, Shah Alam, Malaysia. Prior to continuing her Master's degree, she worked as an Engineer in the telecommunication industry for about 6 years. Her current research interests include lightning physics, lightning protection, lightning prediction, artificial intelligence such as artificial neural network (ANN) and evolutionary programming.



Norazlan Hashim received his B. Eng degree in Electrical Engineering and M. Eng degree in Electrical Energy & Power System from the University of Malaya in 2001 and 2007 respectively. He is currently a senior lecturer in the faculty of electrical engineering, Universiti Teknologi MARA (UiTM) Shah Alam. His research interest includes maximum power point tracking (MPPT) technology and power electronic techniques.