

A review on harmonics elimination in real time for cascaded H-bridge multilevel inverter using particle swarm optimization

Muhammad Tayyab Yaqoob¹, Mohd. Khairil Rahmat², Siti Marwangi Mohamad Maharum³,
Mazliham Mohd. Su'ud⁴

^{1,2}Electrical Engineering Section, Universiti Kuala Lumpur, British Malaysian Institute, Selangor, Malaysia

³Electronics Technology Section, Universiti Kuala Lumpur, British Malaysian Institute, Selangor, Malaysia

⁴Universiti Kuala Lumpur, Malaysian France Institute, Selangor, Malaysia

Article Info

Article history:

Received May 1, 2020

Revised Jan 4, 2021

Accepted Jan 24, 2021

Keywords:

Cascaded H-bridge

Multilevel inverter

Particle swarm optimization

Selective harmonics elimination

ABSTRACT

Renewable energy has a great importance for power generation as it does not use the fossils fuels. Energy generated from alternative energy sources are weather dependent. To generate a continuous power to meet the load requirements, Battery energy storage system are used. Power conversion process must be much efficient as possible to convert the DC stored energy into AC. This conversion process is usually done by the help of inverters. This paper gives the brief overview on three main categories of multilevel inverter like cascaded h-bridge, neutral point clamped and flying capacitor multilevel inverter and highlights their advantages which can also help the scholars to deeply explore the categories of multilevel inverter. Harmonic elimination is usually done by controlling the switching angles of the inverter. Among all the switching angles techniques, selective harmonic elimination pulse width modulation (SHEPWM) technique is widely used, that has also discussed in this paper. Furthermore, to eliminate the harmonics using SHEPWM, it has the set of nonlinear transcendental equations, these set of equations can be effiecently solved by the optimization methods. The most efficient and reliable optimization method like particle swarm optimization has been discussed with multiple objective functions in this paper. This paper will help the scholars to understand the finest category of multilevel inverter for harmonic elimination in terms of efficiency and output quality.

This is an open access article under the [CC BY-SA](https://creativecommons.org/licenses/by-sa/4.0/) license.



Corresponding Author:

Mohd. Khairil Rahmat

Electrical Engineering Section, British Malaysian Institute

University Kuala Lumpur (UniKL)

Kuala Lumpur, Malaysia

Email: mkhairil@unikl.edu.my

1. INTRODUCTION

Energy generation process using fossils fuels are not considered as an effective method as it effects the environment and climate. Renewable energy sources (RES) produced the energy with nearly zero carbon emissions [1]-[3]. The power generation from these sources are weather dependent. This is the reason energy generated from RES needs to be store in energy storage devices (ESD) like battery, fuel cell, super capacitors etc. Energy stored in these storage devices are in direct current (DC) form, whereas mostly appliances works in alternating current (AC) form, A device, that is used to convert DC into AC, called inverter relates to RES or ESD to meet the appliances requirements [4], [5]. Inverters are used for grid-connected, flexible alternating current transmissions systems (FACTS), because of its low cost, flexibility, and effectiveness for

power conversion it is getting an attention for the scholars [6]-[12]. Grid connected Inverters increases the significance in photovoltaic cells, windmills, which will occupy the larger-scale photovoltaic cells [13].

Devices that uses alternating current are smart devices, lightings, motors are powered by inverters [14]-[17]. Energy utilization of compressors and other electronic equipment's can be done by combining inverters with varying its switching frequency [18]. Moreover, it also controls the voltage stability and variation in voltage in electrical power systems [15], [18]-[20]. Due to these changes, lifetime and quality of the devices may get affected by varying the torque and ripples of electrical appliances. Inverters has many advantages; however, the large number of unwanted harmonics appear at the output of multilevel inverter which effect the electrical and mechanical parts of the systems [21]-[24]. Switching frequency plays a vital role to minimize the harmonics, Because of high amplitude of fundamental frequency, harmonics having low order becomes more harmful for the system. The presence of unwanted harmonics can also be reduced by reducing the switching losses present in the power switches. Low order harmonics at the output of multilevel inverter generate the complex problems specially at the distribution side when this inverter relates to the grid [25]-[26]. Power quality at the output of inverter also get affected by these disturbances like fluctuations and harmonics [27].

To overcome these problems, researchers have come up with many techniques that depends on modulation of the output waveform to minimize the harmonics, which makes the inverter more reliable and efficient [28]. A special type of inverter that gives the nearly sinusoidal waveform at the output are called the multilevel inverters. This idea has been introduced in 1980s, the word multi in multilevel inverter means that it consists of multi steps waveform at the output. Harmonics, electromagnetic interference, and quality in inverters are directly related to the switching frequency, lesser the switching frequency will yield the better efficiency of inverter [29]. The multilevel inverter mainly has three types, flying capacitor (FC), diode clamped (DC) and cascaded H-bridge (CHB). This paper discusses the harmonic elimination in CHB multilevel inverter as it is most suitable type for renewable energy applications. To control the switching frequency of this inverter there are two possibilities, selective harmonic elimination (SHE) and space vector control (SVC). Whereas SHE works on high switching frequency and SVC works on a low switching frequency. Pulse width modulation technique works on high switching frequency and switches of the inverter commutates multiple times in one cycle [30], and switch is commutated either once or twice in low switching frequency. For high power and medium power applications SHE is mostly used process.

This paper gives the brief overview of basic configurations of multilevel inverters (MLI), pros and cons and recently research that has been done on three main types of MLI. The types that are discussed in this paper are neutral point clamped (NPC), flying capacitor (FC), and cascaded H-Bridge (CHB) Multilevel inverter. Modulation technique like Selective harmonic elimination pulse width modulation (SHEPWM) has been discussed in detail and the recent articles related to this technique has been summarized here. Furthermore, the advantages of optimization methods like PSO and GA over mostly used numerical methods newton raphson (NR) and latest papers has been summarized in this paper. Fundamental concepts and types of multilevel inverter is presented Section 2. Whereas Section 3 covers the selective harmonic techniques. The latest papers which uses particle swarm optimization (PSO) methods for harmonic elimination having different objective functions has been summarized in section 4.

2. MULTILEVEL INVERTER

Multilevel inverter gives the nearly sinusoidal waveform at the output by taking the several voltage sources as an input. It has many advantages as compared to conventional two-level inverter which uses fundamental switching frequency pulse width modulation (PWM) approach. Multilevel inverter is used to generate the nearly sinusoidal waveform either from an ESD or directly from DC power generation plant like Photovoltaic cells. The main advantage of multilevel inverter is that the increment in number of levels leads to the increment in output voltage and staircase waveform. The staircase waveform supports the reduction in total harmonic distortion (THD). Quality of Staircase waveform is high in terms of harmonics reduction and low voltage stress among power switches. Three main types of multilevel inverters have been applied in medium and high-power applications like neutral point clamped (NPC), flying capacitor (FC) and cascaded H-bridge (CHB) multilevel inverter. The number of required components in CHB is lesser than the other two techniques. Details of the number of components can be shown in Table 1. It also shows the difference in different MLI topologies. As CHB requires a least number of components that enables its simple structure with almost minute complexity. Additionally, with a least number of components it can also deliver power for high voltage power applications as compared to other. Additionally, merits and demerits of three types of inverter are shown in Table 2.

Table 1. Comparison of multilevel inverters techniques

Topology	Power Switches	Clamping Diodes	Clamping Capacitors	DC Bus Capacitors
NPC	2 (L-1)	(L-1) (L-2)	0	(L-1)
FC	2 (L-1)	0	(L-1) (L-2)/2	(L-1)
CHB	2 (L-1)	0	0	(L-1)/2

2.1. Neutral point clamped multilevel inverter

This type of inverter is effectively a three-level diode clamped converter that was introduced by Nabae et al, [31]. This type of inverter has designed to produce a small harmonic output voltage for high efficiency variable frequency drive circuits. Predominantly the three level NPC is shown in Figure 1(a), the further neutral point that is given at every leg has individual states that are, $V_{dc}/2$, $-V_{dc}/2$ and zero. To get the output voltage of $V_{dc}/2$ and $-V_{dc}/2$, the switches S_1 S_2 and S_1' and S_2' need to be switch on in a specific pattern to give the output waveform like a staircase. The number of Capacitors (C) and clamping diodes (cd) for NPC multilevel inverter can be easily findout by (1) and (2):

$$C = n - 1 \tag{1}$$

$$cd = C * (n - 2) \tag{2}$$

Whereas Figure 1(b) shows the five-level NPC multilevel inverter [8]. The circuit diagram consists of four capacitors for five level NPC design. C_1 , C_2 , C_3 and C_4 . While comparing the NPC with other multilevel inverter [32]-[34], this type of inverter has widely used because of its efficiency and lesser leakage current [35], [36]. Given that NPC works on a mutual DC bus, the requirement of Capacitor of this inverter is reduced. This is the reason it is feasible for back-to-back topology; this inverter has few disadvantages as well like difficulty in real time power flow [37], [38]. Stabilizing and balancing the DC voltage of Capacitor is an important factor to consider for NPC design. Whereas a single supply gives the DC-bus to the inverter as the upper and lower load of the DC link capacitor is the problem. One other solution is for addressing the above problem is solved by [39], [40]. Although these solutions have high cost, decrease the power factor, and increases the complexity of the control system. Another passive circuit has been proposed in [38] to increase the power range of the whole system while maintaining the voltage stabilization and inequality in DC voltage system. A balance booster system is proposed in [41], to solve the stabilization problem, relates to the load in parallel. Further to reduce voltage stress, uniform input voltage and output voltage THD a novel five-level voltage source inverter is presented in [42]. The model proposed in [8] doesn't need further semiconductor power switches to connect in series thus it has a high-quality output voltage as compared to conventional NPC.

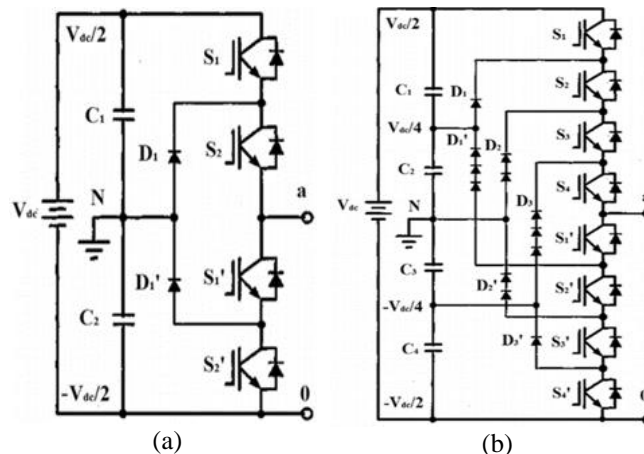

Figure 1. Neutral point clamped multilevel inverter (a) 3-level (b) 5-level [8]

2.2. Flying capacitor multilevel inverter

Flying capacitor (FC-MLI) has a similar structure as NPC it has been firstly modeled by Maynerd and Foch [32]. Like NPC uses the clamping diode the FC uses a flying capacitor to clamp the device voltage. A

three-level and five-level FC is shown in Figure 2. The structure of three-level NPC and FC are similar, but it differs in switching pattern only. To pass the current for positive cycle like $V_{dc}/2$, S_1 and S_2 will work and for the negative DC input like $-V_{dc}/2$ S_1' and S_2' will be switched on. For zero level either $S_1 S_1'$ or $S_2 S_2'$ is switched on. And to discharge the capacitor it will be done correspondingly [33]. The quantity of capacitors that is linked with DC and the quantity of auxiliary capacitors can be found out with the help of (3) and (4), respectively.

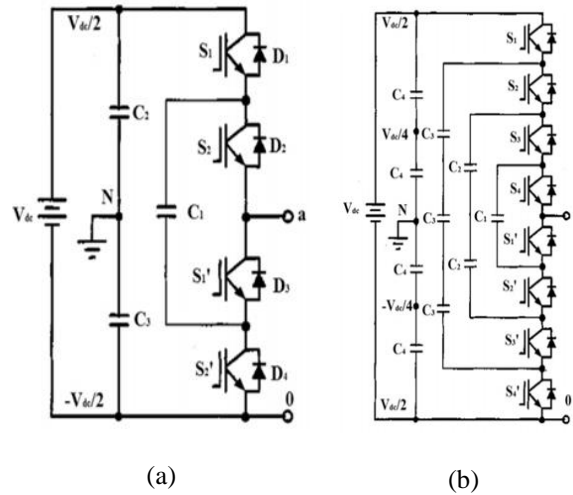

Figure 2. Flying capacitor multilevel inverter (a) 3-level (b) 5-level [8]

$$\text{DC capacitors} = n - 1 \tag{3}$$

$$\text{Auxiliary Capacitors} = n - 1 \times \frac{n-2}{2} \tag{4}$$

The increment in number of levels for FC-MLI increases the complexity in controlling the system. This is the reason number of levels needs to be optimum so that it gives the nearly sinusoidal output and high-performance controller as well [44]. An alternative switching state for a specific voltage level of FC-MLI is explained in Table 3 and Figure 2(b). To switch it for 1010 and 0101 first capacitor will store and release the charge, respectively. Thus, the significant issue of FC is to control the charging and discharging of the capacitors in a specific time to get the nearly sinusoidal waveform at the output. The significant factor of FC over NPC is its phase layings-off. These phase layings off have the quality to either charge or discharge the capacitor, the power consumption of DC sources to balance the control system across many leves [45]. Therefore, FC has lesser voltage stress, smaller size of output filter and lesser THD [46]. Although few researchers and scholars claim that FC is better than NPC in terms of lesser number of components but FC also has some disadvantages too like the controlling of charging and discharging of capacitors require a complex method which leads to poor switching efficiency. Accordingly, scholars have contributed their work to solve these issues in [37] to minimize the voltage distortion at the input side of FC-MLI. Further merits and demerits of FC and other MLI are shown in Table 2.

Table 2. Pros and cons of multilevel inverters [48]

Types	Advantages	Disadvantages
NPC-MLI	<ul style="list-style-type: none"> • Easy to model • Reduced voltage stress and lesser harmonics [31] 	<ul style="list-style-type: none"> • Number of components increases as output level increases • Complexity increases while balancing the voltage level of DC-link Capacitor [37]
FC-MLI	<ul style="list-style-type: none"> • Similar phase so output voltage can be easily balanced and lower device stress [37] • Lesser THD • Lesser the size of Output filter, • Reduced number of components 	<ul style="list-style-type: none"> • Difficulty increases while designing at higher levels [40] • Need huge number of Capacitor • Not efficient in switching frequency [37] • Installation cost is high
CHB-MLI	<ul style="list-style-type: none"> • Reliability is high, fault toleant [48] • Ability to design easily for higher number of levels 	<ul style="list-style-type: none"> • Every Cell has individual DC source [37] • Voltage is not balance among all phases of inverter

Table 3. Effect of current polarity and switching States [43]

Voltage Level	Switching State	Current Polarity	State of Capacitor	State of Capacitor
1/2 Vdc	1100	Ia > 0	S1, S2	Unchanged
		Ia < 0	D1, D2	Unchanged
	1010	Ia > 0	S1, D1, C3	Charges C1
		Ia < 0	S1, C1, D1	Discharges C1
-1/2 Vdc	101	Ia > 0	D4, C1, S2	Discharges C1
		Ia < 0	S2, C1, D2	Charges C1
	11	Ia > 0	D3, D4	Unchanged

2.3. Cascaded H-bridge multilevel inverter

A Cascaded H-bridge multilevel inverter (CHB-MLI) is made by connecting the many H-bridge inverters in such a way that the output of every H-bridge sums up with other to make the stair case waveform at the output. Every H-bridge, usually called a cell, has a separate DC source as shown in Figure 3 [38]. Different output is usually been generated by this type of inverter like Vdc, 0 and -Vdc. To get the output of Vdc S1 and S4 are switched on and for -Vdc S2 and S3 are turned on. Since the output voltage of the CHB-MLI is the sum of all the h-bridges as given in (5). The number of levels from this type of inverter can be calculated by $n = 2S+1$ where S is the number of DC sources [47].

$$V_a = V_1 + V_2 + V_3 + V_4 \tag{5}$$

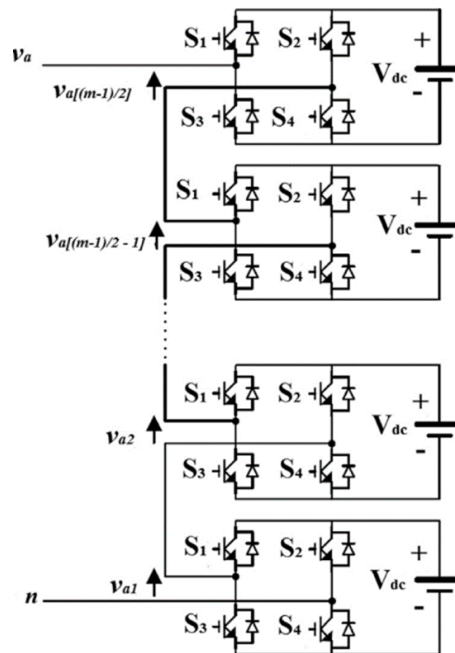

Figure 3. Cascaded H-bridge multilevel inverter [37]

Advantages of CHB-MLI has been stated in [8] that includes lesser components, simple structure, and easy switching strategy. The output voltage of this inverter can easily be adjusted by increasing and decreasing the number of H-bridges. As the output voltage levels are calculated by $n = 2S+1$, that is far more than DC source. Therefore, this type of inverter makes the manufacturing process more clear and cheaper. In other words, CHB-MLI is far better than NPC-MLI and FC-MLI in terms of reliability and best fault tolerance capability. These advantages assist the inverter to perform better under lower DC input voltage [48]. Multilevel inverters that have been mentioned in this paper has several advantages and disadvantages. These pros and cons of these inverters plays a significant role in its development. The NPC-MLI can be used to integrate it with the grid. But due to its increment in semiconductor devices, it is not considered as a good approach for grid connected power systems. Similar concerns apply for FC-MLI, to control the capacitor charging and discharging will be much difficult to design it for higher number of levels. This problem has

been addressed in [48] to balance the capacitor voltage in every individual cell. Method presented in [48] has been tested for NPC-MLI and CHB systems. The results obtained from this method prove that it is applicable for medium and high-power applications. On the contrary a third harmonic injection pulse width modulation (THIPWM) for seven level has been tested and finds out that THIPWM is better than sinusoidal pulse width modulation (SPWM). THIPWM has lesser harmonics in the output of MLI and highest output power quality. The idea proposed in [8] uses particle swarm optimization (PSO) to find out the optimal switching angles for CHB-MLI. From this study it is concluded that optimization methods give much better results than SPWM. Thus, the new scheme proposed after this is called the selective harmonic elimination pulse width modulation (SHEPWM) in which the selected harmonics are minimized using optimization methods.

3. EFFECT OF LOAD VARIATION IN HARMONICS ELIMINATION

Harmonics in multilevel inverters plays a significant role in efficiency and reliability of overall system. Most important factors depending on the harmonics are due to non-linearity of loads, in-efficient switching angles for insulated gate bi-polar transistors (IGBT), pulse width waveform for generating the required output and variation in reactance of output load. The effect of load variation in harmonic elimination section further divides into four subsections, section one describes the effect of non-linear loads on harmonics, section two briefly explain the implementation of real-time calculation and implementation of switching angles while handling the IEEE 519 standard for THD, section three describes the selective harmonic elimination using pulse width modulation technique whereas last section describes the significance of switching angles for harmonics minimization in multilevel inverter.

3.1. Non-linear loads

Load variation plays a significant role in harmonics generation, as mentioned in [29], online elimination of harmonics has been done using modified PSO while the load varies. Nonlinearity in the system arises when the voltage applied across its terminals has changed. When the load varies, it changes the impedance that enables the non-linearity in the system no matter it is connected to a pure sinusoidal voltage source [49]. These non-linearities contains the harmonics that relate with the impedance of the inverter and the grid that is connected to it [51]. Unwanted harmonics becoming the major issue as they are leading due to increment in power quality related issues. Fifth and seventh harmonics elimination has been done in [52] using a new control strategy in the output voltage of stator. Non-linearity in loads also arises when an inverter is connected to a distributed grid. The idea proposed in [52] provides an additional filtering for harmonics in non-linear loads. This idea can be applied for multilevel inverter or to any other renewable energy sources. Validation of these techniques are done by implementing a three-level neutral point clamped inverter that connect a grid having a non-linear load. As the non-linear loads continuously generates harmonics that effects the performance therefore, real-time harmonic elimination is necessary to improve the system performance and stability.

3.2. Real-time

As described in the above section, harmonics changes as the non-linearity in the load exist. Such as a three-phase or single-phase motor varies it speed and reactance with respect to a load, non-linearity in a system exist and it changes with respect to time. Closed-loop devices control the harmonics much better than open as mentioned in [53]. Modulation index dependent having closed loop controlling has been done for CHB multilevel inverter. PSO is used in this paper to eliminate the harmonics by having the modulation index as a feedback input. While in real-time scenario not only the non-linearity effects the harmonics, DC input voltage also plays a significant role on the stability of the output voltage of an inverter. This issue has been solved by [54] to maintain the THD for 5th, 7th, 9th, and 11th order harmonics in seven-level inverter. State table has been made to generate the optimum switching angles again with the help of a microcontroller. Re-optimization has been done in this paper for 12% reduction in THD during fault scenario. Artificial neural networks (ANN) are also used for real-time implementation of switching angles. PSO and ANN both has been utilized in [55] to find out the best solution set for the known input voltages and unknown switching angles. The method proposed in [55] has been validated in MATLAB/SIMULINK.

3.3. Selectie harmonic elimination

Through SHE-PWM method unwanted harmonics can be removed easily from the output of multilevel inverter [56]. A transcendental equation is used to minimize the switching angles to minimize the harmonics from the output [57]. However, Sine and Cosine functions contains important roles and convergence to the optimum explanation is difficult to attain. To discover the utmost switching angles to minimize the unwanted harmonics, diverse mathematical models have been presented like Gorbner basis

theory and symmetric polynomials. As these mathematical models compute initial guesses, sometimes these guesses are not accurately nominated that surge the complexity cost. High-level inverters are not able to perform much efficiently using these mathematical methods [24]-[26]. To overcome these issues optimization methods directly using Artificial Intelligence techniques has been used. The main point of utilizing these algorithms are they are not wide-ranging and not depends on early suppositions hence decreases computational cost. Furthermore, these optimization methods can easily work on low cost DSP, however there are many other procedures in which some of the bio-inspired algorithms are PSO, GA, bee algorithm (BA) and differential evolution (DE) [49]. Nonlinearity in Low order harmonics equations can be found out with the help of objective functions. Usually researchers use different objective functions to lessen the harmonics. Diverse procedures have been suggested to clarify the harmonic elimination problem. The waveform at the output voltage of multilevel inverter using Fourier series in SHE-PWM is given by (6).

$$f_{N(t)} = \frac{a_0}{2} + \sum_{n=1}^N \left(A_n \cos \frac{2\pi n t}{T} + V_n \sin \frac{2\pi n t}{T} \right) \tag{6}$$

where a_0 is the dc factor, V_n characterizes odd harmonics and denotes even harmonics. The designs of Multilevel voltage source inverter depend on the assembly of the output waveform, i.e., single switching per level and multi switching per level as shown in Figure 4.

Category-a waveform gives the output voltage but having switching frequency minimum. Whereas category-b uses high switching frequency. (s-1) limits the low order unwanted harmonics, where s is the number of DC supply that are the input side of the inverter. By increasing the number of levels, quality of output waveform also increases. But this increases the complexity and cost of the system that turn out to be more complex. Whereas in category-b without increasing the number of levels can give the better output without increasing the cost and complexity of the system [28]. Quarter symmetrical waveform is shown in Figure 4 with all the consequent DC sources in this way even harmonics becomes the zero, therefore the equation for the type a waveform can be given as.

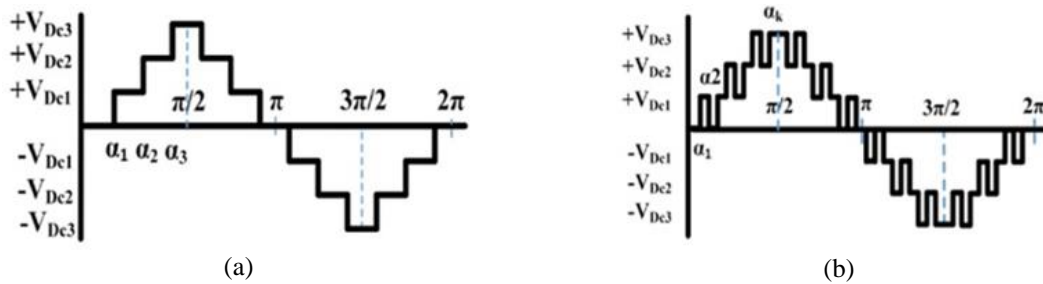

Figure 4. Staircase output voltage waveform of seven-level Multilevel Inverter, (a) single switching per level, (b) multi-switching per level

$$f(t) = V \sin(n\theta) \tag{7}$$

where V_n is the Fourier coefficient, and can be articulated as (8);

$$v_n = \frac{4v_{DC}}{n\pi} \sum_{i=1}^s K_i \cos(n\theta_i) \tag{8}$$

where,

- VDC : is DC voltage,
- i : is the voltage source and
- n : is the harmonic order

The waveform in Figure 4 describes that all angles should be less than 90 degree and must be in an ascending order as mentioned in (9).

$$\theta_1 < \theta_2 < \theta_3 < \theta_4 < \theta_5 < 90^\circ \tag{9}$$

The selective harmonic equations to eliminate nth order harmonics can be further expanded as the set of equation shown as (10):

$$\begin{aligned}
 \cos(\theta_1) + \cos(\theta_2) + \cos(\theta_3) \dots \dots \cos(\theta_n) &= M \\
 \cos(3\theta_1) + \cos(3\theta_2) + \cos(3\theta_3) \dots \dots \cos(3\theta_n) &= 0 \\
 + \cos(5\theta_2) + \cos(5\theta_3) \dots \dots \cos(5\theta_n) &= 0 \\
 \cos(n\theta_1) + \cos(n\theta_2) + \cos(n\theta_3) \dots \dots \cos(n\theta_n) &= 0
 \end{aligned}
 \tag{10}$$

where n is the number of harmonic order and M is the modulation index that defines the pulse width ratio of the switching waveform for IGBTs of the inverter.

3.4. Switching angles

Switching angles plays a significant role for generating waveform for IGBT/MOSFETs. Optimal calculation of switching angles reduces the harmonics from the output of multilevel inverter [29]. Selected lower order harmonics are eliminated in [29] and the overall total harmonic distortion (THD) is reduced by calculating the optimal switching angles. Also, the sudden changes in the harmonics are minimized in [29] by getting the optimum switching angles from the lookup tables. To improve the online application of this single-phase multilevel inverter, author has pre-calculated the switching angles at varying modulation indexes from 0 to 1. 5th, 7th and 11th order harmonics are reduced by [30] in three phase hybrid cascaded multilevel inverter. These harmonics has been reduced by finding the optimal switching angles using modified particle swarm optimization (MPSO) method. Harmonics are also minimized in [58] by finding optimal switching angles using PSO and GA, in which PSO is found better than GA. Hardware and simulation analysis has been done to compare both results. Determination of switching angles has also done in [59] with the help of PSO for harmonics minimization in three phase five level multilevel inverter by solving the transcendental equations. Another comparison of three optimization methods like [58] has been done for selective harmonic minimization in [56]. In this paper comparison of newton raphson (NR), PSO and GA has been done and PSO found better than the other two algorithms. Harmonics elimination is not only done in multilevel inverter, it has also eliminated in [59] through modular multilevel inverter using stair-case modulation strategy with the help of PSO. Switching losses and the stress on device has also reduced in this paper for high-power energy conversion applications by reducing dv/dt losses. From figure 4 pulses of switching pattern can be visualized. Switch s1 and s2 will work for the second half cycle where as s5 and s6 are switched on for positive half cycle rest all switches are high and low for a certain time period to make a nearly sinusoidal waveform at the output as shown in Figure 5.

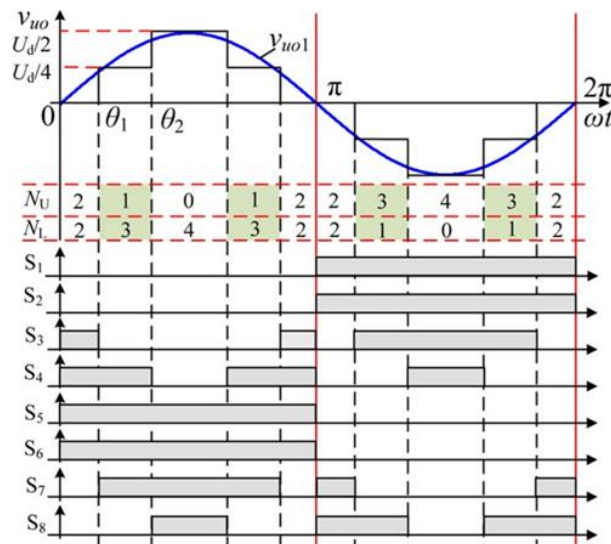

Figure 5. Switching pulses of stair-case multilevel inverter [56]

4. PARTICLE SWARM OPTIMIZATION (PSO)

This section provides the brief overview of multilevel inverter efficiency and its reliability by reducing the harmonics using optimization algorithm PSO. Firing angles or switching angles for the

IGBTs/MOSFETs plays an important role to generate the nearly sinusoidal output waveform at the output of a multilevel inverter. The switching losses are also dependent on the firing angles. These firing angles can be calculated using mathematical techniques or bio-inspired intelligent algorithms. Optimization methods like PSO has been most widely used algorithm for minimizing the harmonics in multilevel inverter. Harmonics also generated due to non-linearity in the load. This non-linearity is because of the reactive and variation in the load. Uncontrollable and non-linear load produces the harmonics that effects the inverter stability and its efficiency. Harmonics produces by the load can be reduced by re-optimizing the switching angles. Real-time calculation of switching angles becomes necessary to increase the inverter efficiency and its reliability. As the computation time of PSO is much higher, therefore scholars have pre-stored the values of switching angles at various modulation indexes in look-up tables. The pseudocode of PSO can be shown in Figure 6. Its computational time depends on the number of iterations and search space like in the initial stage this algorithm initializes its acceleration parameters c_1 , c_2 and W_{max} and W_{min} . The movement of a particle is calculated by (11).

$$v_{ij}^{t+1} = v_{ij}^t \times w^{t+1} + [c_1 \times r_{1j}^t \times (P_{Bestxij}^t - x_{ij}^t)] + [c_2 \times r_{2j}^t \times (G_{Best}^t - x_{ij}^t)] \quad (11)$$

$$x_{ij}^{t+1} = x_{ij}^t + v_{ij}^{t+1} \quad (12)$$

where, w^{t+1} is the inertia weight and it is given by (13):

$$w^{t+1} = W_{max} - \left[\frac{W_{max} - W_{min}}{TNI} \right] \times CI \quad (13)$$

The particle which finds the best position as compared to others personal best after updating the position and velocity, that particle will store its position at PBest. The updating process will continue until the particles reaches at the end point of the iteration. In [61] PSO algorithm is proposed for harmonic elimination in multilevel inverters using the objective function given in (14). The method proposed in this paper is usually used for large variable frequency drives (VFDs), uninterruptable power supplies (UPS) and grid connected renewable energy system. Method proposed in [50] mainly focuses on computational time and require less time to reach to global minimum. Same objective function which is used in [61], is utilized by [61] to reduce the harmonics using modular multilevel converter. In [61] modular multilevel converter is proposed for high power applications and mainly focuses on eliminating the harmonics with unequal input of DC sources. The technique presented in this paper is also able to simplify the switching angles with the help of angle rotation scheme. The initial values of particles to solve the set of non-linear transcendental equations is calculated by newton raphsons (NR) method. Further the switching angles has been optimized by PSO.

$$F(\theta_1, \theta_2, \theta_3) = [\sum_{n=1}^s V_1 \cos(\theta_n - m)]^2 + [\sum_{n=1}^s V_2 \cos(3\theta_n - m)]^2 + \dots + [\sum_{n=1}^s V_s \cos((2s-1)\theta_s)]^2 \quad (14)$$

Total harmonic distortion is the significant concern for the scholars, therefore the formula of THD has been utilized by researchers as an objective function in [52]. Harmonics order number 5th, 7th, 11th and 13th are being eliminated in [50]. The angles calculated from the objective function given in (15) are implemented in microcontroller for experimental and validation purposes. Same objective function has been used in [51] to further minimize the harmonic on different load conditions. The technique presented in [103] has been store in lookup table which makes it possible for real time harmonic minimization. Outcome of this paper has been validated via simulations and experiments.

$$THD = \left[\frac{1}{a_1^2} \sum (an)^2 \right]^{\frac{1}{2}} \times 100 \quad (15)$$

$$f = |3 \cdot 28M - v_1|^4 + |v_5|^2 + |v_7|^2 \quad (16)$$

In [62] a detailed comparative study of Newton Raphson method, Genetic Algorithm and PSO has been done for harmonic minimization in multilevel inverter. As Selective harmonic elimination is considered as a low switching frequency method. PSO is found much better in [62] by utilizing the objective function given in (16). Same objective function with some modifications in modulation index is utilized by [59] for voltage harmonic elimination and a combination of PSO with mesh adaptive direct search technique has been implemented in this paper to further improve the convergence rate of the proposed algorithm. In this paper three phase seven level CHB is simulated in MATLAB /SIMULINK and experimental analysis has

been done using microcontroller AT90CAN128 with combination of Altera's Cyclone II FPGA. The proposed technique in [59] assumes that the DC input source is same throughout the experiment.

Particle Swarm Optimization

1. Objective function $f(x)$
2. Initialize parameters $c_1, c_2, w_{max}, w_{min}$, and population $nPop$
3. Generate an initial population of particles
4. Evaluate the fitness of each particle and set all initial positions as $P_{best_{x_i}}$
5. **while** ($t < MaxGeneration$) or (! *stop criterion*)
6. select the Gbest particle in swarm, which has the minimum fitness value
7. **for** $i = 1: nPop$
8. Calculate the velocity of particle x_i
9. Update the position of particle x_i
10. **end for** i
11. **for** $i = 1: nPop$
12. evaluate the fitness of updated particle x_i
13. **if** $f(x) < f(P_{best_{x_i}})$,
14. then set current position as $P_{best_{x_i}}$
15. **end if**
16. **end for** i
17. find the best particle.
18. **end while**

Figure 6. Pseudocode of PSO [50]

5. CONCLUSION

Efficiency and reliability are the main concerns specially for multilevel inverters. Harmonic at the output of multilevel inverter plays an important role for its reliability and efficiency. Unwanted harmonics that are generated due to inefficient switching angles and nonlinearity in loads are the main concern for the scholars. This study briefly explains the best category of multilevel inverter by telling the advantages and disadvantages of each category. As compared to NPC and FC, CHB is more reliable and effective design as it also consists of lesser number of components. For switching angles minimization, SHEPWM is effective for harmonic elimination. The set of non-linear equations formed by SHEPWM can be easily solved by optimization method like PSO. This paper concludes that for harmonic elimination in multilevel inverter, CHB technique is better than NPC and FC, for switching purposes the SHEPWM technique is better and to solve the set of nonlinear transcendental equations, PSO gives promising result. The multiple objective functions that has recently used by other scholars has been discussed and its advantages has been presented in this paper. While for real time applications it can be concluded from other papers that the optimum switching angles that has been calculated can be stored in a look-up table for better harmonic minimization.

REFERENCES

- [1] Strasser T., et al., "A review of architectures and concepts for intelligence in future electric energy systems," *IEEE Transactions on Industrial Electronics*, vol. 62, no. 4, pp. 2424-2438, 2015.
- [2] Kamal W. A., "Improving energy efficiency-the cost-effective way to mitigate global warming," *Energy Conversion and Management*, vol. 38, no. 1, pp. 39-59, 1997.
- [3] Demirbas M. F., Balat M., "Recent advances on the production and utilization trends of biofuels: a global perspective," *Energy Conversion and Management*, vol. 47, no. 15-16, pp. 2371-2381, 2006.
- [4] Yuksel I., Kaygusuz K., "Renewable energy sources for clean and sustainable energy policies in Turkey," *Renewable and Sustainable Energy Reviews*, vol. 15, no. 8, pp. 4132-4144, 2011.
- [5] AbuBakr S., Bahaj A. S., "Generating electricity from the oceans," *Renewable and Sustainable Energy Reviews*, vol. 15, no. 7, pp. 3399-3416, 2011.
- [6] Kouro S, Malinowski M., "Recent advances and industrial applications of multilevel converters," *IEEE Transactions on Industrial Electronics*, vol. 57, no. 8, pp. 2553-2580, 2010.
- [7] Malinowski M., Gopakumar K., Rodriguez J., Perez M. A., "A survey on cascaded multilevel inverters," *IEEE Transactions on Industrial Electronics*, vol. 57, no. 7, pp. 2197-2206, 2010.
- [8] Rodríguez J., Lai J. S., Peng F. Z., "Multilevel inverters: a survey of topologies, controls, and applications *IEEE Transactions on Industrial Electronics*, vol. 49, no. 4, pp. 724-738, 2002.
- [9] Rodríguez J., et al., "Multilevel voltage-source-converter topologies for industrial medium-voltage drives," *IEEE Transactions on Industrial Electronics*, vol. 54, no. 6, pp. 2930-2945, 2007.
- [10] Colak I., Kabalci E., Bayindir R., "Review of multilevel voltage source inverter topologies and control schemes," *Energy Conversion and Management*, vol. 52, no. 2, pp. 1114-1128, 2011.

- [11] Venkataramanaiah J., Suresh Y., Kumar A., "A review on symmetric, asymmetric, hybrid and single DC sources based multilevel inverter topologies," *Renewable and Sustainable Energy Reviews*, vol. 76, pp. 788-812, 2017.
- [12] Hasan N. S., Rosmin N., Musta H., "Reviews on multilevel converter and modulation techniques," *Renewable and Sustainable Energy Reviews*, vol. 80, pp. 163-174, 2017.
- [13] Hasan N. S., Hassan M. Y., Majid M. S., Rahman H. A., "Review of storage schemes for wind energy systems," *Renewable and Sustainable Energy Reviews*, vol. 21, pp. 237-247, 2013.
- [14] Kaldellis J. K., Kavadias K. A., Koronakis P. S., "Comparing wind and photovoltaic standalone power systems used for the electrification of remote consumers," *Renewable and Sustainable Energy Reviews*, vol. 11, no. 1, pp. 57-77, 2007.
- [15] Bernal-Agustín J. L., Dufo-López R., "Simulation and optimization of stand-alone hybrid renewable energy systems," *Renewable and Sustainable Energy Reviews*, vol. 13, no. 8, pp. 2111-2118, 2009.
- [16] Lidula N. W. A., Rajapakse A. D., "Microgrids research: a review of experimental microgrids and test systems," *Renewable and Sustainable Energy Reviews*, vol. 15, no. 1, pp. 186-202, 2011.
- [17] Etesami M. H., Farokhnia N., Fathi S. H., "Colonial competitive algorithm development toward harmonic minimization in multilevel inverters," *IEEE Transactions on Industrial Informatics*, vol. 11, no. 2, pp. 459-466, 2015.
- [18] Khan N., Abas N., "Comparative study of energy saving light sources," *Renewable and Sustainable Energy Reviews*, vol. 15, no. 1, pp. 296-309, 2011.
- [19] Saidur R., Mekhilef S., Ali M. B., Safari A., Mohammed H. A., "Applications of variable speed drive (VSD) in electrical motors energy savings," *Renewable and Sustainable Energy Reviews*, vol. 16, no. 1, pp. 543-550, 2012.
- [20] Bhutto A. W., Bazmi A. A., Zahedi G., "Greener energy: issues and challenges for Pakistan-wind power prospective," *Renewable and Sustainable Energy Reviews*, vol. 20, pp. 519-538, 2013.
- [21] Balasubramonian M., Rajamani V., "Design and real-time implementation of SHEPWM in single-phase inverter using generalized Hopfield neural network," *IEEE Transactions on Industrial Electronics*, vol. 61, no. 11, pp. 6327-6336, 2014.
- [22] Salas V., Ollas E., Alonso M., Chenlo F., "Overview of the legislation of DC injection in the network for low voltage small grid-connected PV systems in Spain and other countries," *Renewable and Sustainable Energy Reviews*, vol. 12, no. 2, pp. 575-583, 2008.
- [23] Basak P., Chowdhury S., Halder Nee Dey S., Chowdhury S. P., "A literature review on integration of distributed energy resources in the perspective of control, protection and stability of microgrid," *Renewable and Sustainable Energy Reviews*, vol. 16, no. 8, pp. 5545-5556, 2012.
- [24] Salas V., Ollas E., "An analysis of the technical exigencies and CE marking relative to low voltage (less than 5 kW) photovoltaic inverters marketed in Spain," *Renewable and Sustainable Energy Reviews*, vol. 13, no. 6-7, pp. 1635-1640, 2009.
- [25] Abdelaziz E. A., Saidur R., Mekhilef S., "A review on energy saving strategies in industrial sector," *Renewable and Sustainable Energy Reviews*, vol. 15, no. 1, pp. 150-168, 2011.
- [26] Meral M. E., Diner F., "A review of the factors affecting operation and efficiency of photovoltaic based electricity generation systems," *Renewable and Sustainable Energy Reviews*, vol. 15, no. 5, pp. 2176-2184, 2011.
- [27] Goh H. S., Armstrong M., Zahawi B., "The effect of grid operating conditions on the current controller performance of grid connected photovoltaic inverters," *2009 13th European Conference on Power Electronics and Applications*, Barcelona, 2009, pp. 1-8.
- [28] Dahidah M. S. A., Konstantinou G., Agelidis V. G., "A review of multilevel selective harmonic elimination PWM: formulations, solving algorithms, implementation and applications," *IEEE Transactions on Power Electronics*, vol. 30, no. 8, pp. 4091-4106, 2015.
- [29] N. Mittal, B. Singh, S. P. Singh, R. Dixit and D. Komar, "Multi-level inverter: a literature survey on topologies and control strategies," *2012 2nd International Conference on Power, Control and Embedded Systems*, Allahabad, 2012, pp. 1-11.
- [30] M. G. H. Aghdam, S. S. Fathi and A. Ghasemi, "The analysis of conduction and switching losses in three phase OHSW multilevel inverter using switching functions," *2005 International Conference on Power Electronics and Drives Systems*, Kuala Lumpur, 2005, pp. 209-218.
- [31] Nabae, A., Takahashi, I., & Akagi, H., "A new neutral-point-clamped PWM inverter," *IEEE Transactions on industry applications*, vol. IA-17, no. 5, pp. 518-523, 1981.
- [32] Xu, L., & Agelidis, V. G., "Active capacitor voltage control of flying capacitor multilevel converters," *IEE Proceedings-Electric Power Applications*, vol. 151, no. 3, pp. 313-320, 2004.
- [33] Taleb, R., Benyoucef, D., Helaimi, M., Boudjemaa, Z., & Saidi, H., "Cascaded H-bridge asymmetrical seven-level inverter using THIPWM for high power induction motor," *Energy Procedia*, vol. 74, pp. 844-853, 2015.
- [34] Gao, C., Jiang, J., Yang, X., Xie, L., & Cao, K., "A novel topology and control strategy of modular multilevel converter (MMC)," *2011 International Conference on Electrical and Control Engineering*, Yichang, 2011, pp. 967-971.
- [35] Zhang, L., Sun, K., Feng, L., Wu, H., & Xing, Y., "A family of neutral point clamped full-bridge topologies for transformerless photovoltaic grid-tied inverters," *IEEE Transactions on Power Electronics*, vol. 28, no. 2, pp. 730-739, 2012.
- [36] Abu-Rub, H., Holtz, J., Rodriguez, J., & Baoming, G., "Medium-voltage multilevel converters-State of the art, challenges, and requirements in industrial applications," *IEEE Transactions on Industrial Electronics*, vol. 57, no. 8, pp. 2581-2596, 2010.
- [37] Wang, M., Hu, Y., Zhao, W., Wang, Y., & Chen, G., "Application of modular multilevel converter in medium voltage high power permanent magnet synchronous generator wind energy conversion systems," *IET Renewable Power Generation*, vol. 10, no. 6, pp. 824-833, 2016.

- [38] Merahi, F., & Berkouk, E. M., "Back-to-back five-level converters for wind energy conversion system with DC-bus imbalance minimization," *Renewable Energy*, vol. 60, pp. 137-149, 2013.
- [39] Pou, J., Boroyevich, D., & Pindado, R., "Effects of imbalances and nonlinear loads on the voltage balance of a neutral-point-clamped inverter," *IEEE Transactions on power electronics*, vol. 20, no. 1, pp. 123-131, 2015.
- [40] Tallam, R. M., Naik, R., & Nondahl, T. A., "A carrier-based PWM scheme for neutral-point voltage balancing in three-level inverters," *IEEE Transactions on Industry Applications*, vol. 41, no. 6, pp. 1734-1743, 2005.
- [41] Mohzani, Z., McGrath, B. P., & Holmes, D. G., "The balancing properties of DC link compensation for 3-phase Neutral Point Clamped (NPC) Converter," *Proceedings of The 7th International Power Electronics and Motion Control Conference*, Harbin, 2012, pp. 574-579.
- [42] Narimani, M., Wu, B., & Zargari, N. R., "A novel five-level voltage source inverter with sinusoidal pulse width modulator for medium-voltage applications," *IEEE Transactions on Power Electronics*, vol. 31, no. 3, pp. 1959-1967, 2016.
- [43] Adam, G. P., Anaya-Lara, O., Burt, G. M., Finney, S. J., Williams, B. W., & McDonald, J. R., "Comparison between flying capacitor and modular multilevel inverter," *In IECON 2009, the 35th Annual Conference of the IEEE Industrial Electronics Society and ICELIE 2009, the 3rd IEEE International Conference on E-Learning in Industrial Electronics*, pp. 1-6, 2009.
- [44] Chen, D., & Xie, S., "Review of the control strategies applied to active power filters," *2004 IEEE International Conference on Electric Utility Deregulation, Restructuring and Power Technologies. Proceedings*, Hong Kong, China, 2004, pp. 666-670, vol. 2.
- [45] Kala, P., & Arora, S., "A comprehensive study of classical and hybrid multilevel inverter topologies for renewable energy applications," *Renewable and Sustainable Energy Reviews*, vol. 76, pp. 905-931, 2017.
- [46] Meynard, T. A., Foch, H., Thomas, P., Courault, J., Jakob, R., & Nahrstaedt, M., "Multicell converters: basic concepts and industry applications," *IEEE transactions on industrial electronics*, vol. 49, no. 5, pp. 955-964, 2001.
- [47] Sumithira, T. R., & Nirmal Kumar, A., "Elimination of harmonics in multilevel inverters connected to solar photovoltaic systems using ANFIS: an experimental case study," *Journal of applied research and technology*, vol. 11, no. 1, pp. 124-132, 2013.
- [48] Rahim, N. A., Elias, M. F. M., & Hew, W. P., "Transistor-clamped H-bridge based cascaded multilevel inverter with new method of capacitor voltage balancing," *IEEE Transactions on Industrial Electronics*, vol. 60, no. 8, pp. 2943-2956, 2012.
- [49] Sallama, A., Abbod, M., & Khan, S. M., "Applying sequential particle swarm optimization algorithm to improve power generation quality," *International Journal of Engineering and Technology Innovation*, vol. 4, no. 4, pp. 223-233, 2014.
- [50] Memon, M. A., Mekhilef, S., Mubin, M., & Aamir, M., "Selective harmonic elimination in inverters using bio-inspired intelligent algorithms for renewable energy conversion applications: A review," *Renewable and Sustainable Energy Reviews*, vol. 82, pp. 2235-2253, 2018.
- [51] Ray R. N., Chatterjee D., Goswami S. K., "An application of PSO technique for harmonic elimination in a PWM inverter," *Applied Soft Computing*, vol. 9, no. 4, pp. 1315-1320, 2009.
- [52] Ray R. N., Chatterjee D., Goswami S. K., "A PSO based optimal switching technique for voltage harmonic reduction of multilevel inverter," *Expert Systems with Applications*, vol. 37, no. 12, pp. 7796-7801, 2010.
- [53] Sanchez Reinoso C. R., De Paula M., Milone D. H., Buitrago R. H., "Photovoltaic inverters optimization," *Energy Procedia*, vol. 14, no. 2011, pp. 1484-1489, 2012.
- [54] Routray, A., kumar Singh, R., & Mahanty, R., "Harmonic Minimization in Three-Phase Hybrid Cascaded Multilevel Inverter Using Modified Particle Swarm Optimization," *IEEE Transactions on Industrial Informatics*, vol. 15, no. 8, pp. 4407-4417, 2019.
- [55] Yaqoob, M. T., Shahid, Z., Rahmat, M. K., Alam, M. M., & Su'ud, M. M., "Selective Harmonic Elimination in Cascaded H-Bridge Multilevel Inverters using Particle Swarm Optimization: A review," *2019 13th International Conference on Mathematics, Actuarial Science, Computer Science and Statistics (MACS)*, Karachi, Pakistan, 2019, pp. 1-5.
- [56] Zhai, J., Ye, J., Wang, L., Feng, E., Yin, H., & Xiu, Z., "Pathway identification using parallel optimization for a complex metabolic system in microbial continuous culture," *Nonlinear Analysis: Real World Applications*, vol. 12, no. 5, pp. 2730-2741, 2011.
- [57] Buccella, C., Cecati, C., Cimatorini, M. G., Kulothungan, G., Edpuganti, A., & Rathore, A. K., "A selective harmonic elimination method for five-level converters for distributed generation," *IEEE Journal of Emerging and Selected Topics in Power Electronics*, vol. 5, no. 2, pp. 775-783, 2017.
- [58] Selvaraj J., Rahim N. A., "Multilevel inverter for grid-connected PV system employing digital PI controller," *IEEE Transactions on Industrial Electronics*, vol. 56, no. 1, pp. 149-158, 2009.
- [59] Alamri, B., Sallama, A., & Darwish, M., "Optimum SHE for cascaded H-bridge multilevel inverters using: NR-GA-PSO," *11th IET International Conference on AC and DC Power Transmission*, Birmingham, 2015, pp. 1-10.
- [60] Al-Othman, A. K., & Abdelhamid, T. H., "Elimination of harmonics in multilevel inverters with non-equal dc sources using PSO," *2008 13th International Power Electronics and Motion Control Conference*, Poznan, 2008, pp. 606-613.
- [61] Shen, K., Zhao, D., Mei, J., Tolbert, L. M., Wang, J., Ban, M., et al., "Elimination of harmonics in a modular multilevel converter using particle swarm optimization-based staircase modulation strategy," *IEEE Transactions on Industrial Electronics*, vol. 61, no. 10, pp. 5311-5322, .
- [62] Kumle, A. N., Fathi, S. H., & Yazdi, S. H., "A novel memetic algorithm approach for selective harmonic elimination in multi-level inverters," *The 5th Annual International Power Electronics, Drive Systems and Technologies Conference (PEDSTC 2014)*, Tehran, 2014, pp. 205-210.

BIOGRAPHIES OF AUTHORS



Muhammad Tayyab Yaqoob received the B.E. degree in electrical engineering from Bahria University Karachi, Pakistan, in 2010, the M.E. degree in electronic engineering from NED University of Engineering & technology, and he is currently pursuing the Ph.D. degree in electrical and electronic engineering from Universiti Kuala Lumpur, Malaysia. His research interest includes with a focus on power electronics devices like multilevel inverters using bio inspired intelligent algorithms.



Ir. Dr. Mohd. Khairil is the Principal Researcher of Universiti Kuala Lumpur's Renewable Energy Research Laboratory (RENERAL) He has obtained his PhD. and MSc. in Electrical Power Engineering from University of Strathclyde, UK and BEng degree from University of Southampton, UK. He also has obtained MBA (Marketing) from Universiti Putra Malaysia. His research interest includes reliability study of electrical power systems, renewable energy and energy efficiency management. He has published many articles and research findings in journals and has presented in many international conferences. Prior to joining the higher education industry, he has involved in various design, installation, testing and commissioning of electrical systems mainly in the integrated electrical back-up power supply systems. He has worked with engineers and technical personnel at various levels in the United Kingdom, Australia, New Zealand, the Philippines, Singapore and Malaysia. He is a Professional Engineer with the Board of Engineers Malaysia (BEM), and a Chartered Engineer (CEng) with the Institution of Engineering and Technology (IET), UK.



Dr. Siti Marwangi Mohamad Maharum is a Senior Lecturer from Electronics Technology Section of Universiti Kuala Lumpur British Malaysian Institute. She received a Bachelor Degree of Engineering in Electrical-Telecommunication from Universiti Teknologi Malaysia in 2010 and later completed her PhD in Electrical Engineering from the same university in 2015. Her research interest is in resource allocation and spectrum management in wireless communication systems. Besides that, she is now active in the research area of crosstalk for 5G applications. She is now appointed as the Principal Investigator for crosstalk characterization evaluation in millimeter wave (mmWave) and successfully delivered the output for two grants in radio resource allocation and access node selection and bandwidth allocation. Her active participation in academia profession had been translated in numerous publications in conferences and journals as well as securing awards winning in innovation competitions.



Mazliham Mohd Su'ud, President, UniKL DSAP, SAP PhD in Computational Intelligence & Decision, University De La Rochelle, France Post Master Degree in Electronics, University De Montpellier II France Master in Electronics Electrotechnics and Automation, Bachelor in Electronics Electrotechnics and Automation, University De Montpellier II France, Diploma in Science, University De Montpellier II, France. Mazliham Mohd Su'Ud received the Ph.D. in computer engineering from the Université de La Rochelle, in 2007, and the master's degree in electrical and electronics engineering from the University of Montpellier, in 1993. Since 2013, he has been the President/CEO of the Universiti Kuala Lumpur, Malaysia