

AC-DC UPF charging circuit for two-wheeler electric vehicle application

Swathi Karike¹, Sudha Rani Donepudi², Kuthuri Narasimha Raju¹

¹Department of Electrical and Electronics Engineering, Koneru Lakshmaiah Education Foundation, Vaddeswaram, India

²Department of Electrical and Electronics Engineering, Sri Vasavi Engineering College, Tadepalligudem, India

Article Info

Article history:

Received Jun 1, 2022

Revised Sep 23, 2022

Accepted Oct 7, 2022

Keywords:

AC-DC

Battery

Charging

Electric vehicle

Unity power factor

ABSTRACT

Extinction and the emission of greenhouse gases from fossil fuels led the field of energy studied took a revolutionary turn towards non-conventional natural sources achieving zero-pollution power. Electric vehicles (EVs) are trending in this new era to reduce the global warming. Due to limitations in storage systems, electric vehicles are not much popular but to reduce the pollution from vehicles, EVs are in must condition and recommended for (public/personal) transportation. EV (battery) is charged through a DC source (converting the available AC supply to DC). The conversion process diminishes the input source power factor and is a worrying factor. This paper addresses the power factor issue while charging the battery of EVs. The paper focuses on maintaining the unity power factor on the source side while charging the battery of the EV from AC-DC conversion. The model is developed and the results are discussed (for three different battery levels) using MATLAB/Simulink software.

This is an open access article under the [CC BY-SA](#) license.

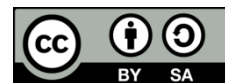

Corresponding Author:

Kuthuri Narsimha Raju

Department of Electrical and Electronics Engineering, Koneru Lakshmaiah Education Foundation

Vaddeswaram, India

Email: Narsimharaju_eee@kluniversity.in

1. INTRODUCTION

The emission of carbon gases leads to global warming depleting the ozone layer and creating a harmful environment for living species. Vehicles using IC engines with crude oil products as fuel are one major system that contributes to depleting the ozone layer and raising the Earth's temperature [1]. With the transition of vehicle systems using sustainable sources like PV-solar system, stability in human-involved climatic conditions can be achieved. The use of electric vehicles (EVs) [2]–[5] shows a progressive move toward controlling global environmental issues. Solar-powered electric vehicles [6] are also becoming popular. Using EVs over gasoline engine vehicles can reduce the running cost significantly while saving environmental energy. The main constraint of using EVs is their range of operation. The use of advanced battery technology and converter technology can help increase the range of EVs and their efficiency.

EVs are vehicles that run purely on electrical appliances and converter technology where the wheel of the EV is driven by an electric motor through a gear system. The charging system placed onboard [7] is trending these days for EVs, which is made possible because of growing technology in power electronics in the automotive sector. The battery system which is installed on the board of EV is charged [8], [9] from the grid (AC) source after being converted to DC type through an AC-DC converter. The battery supplies the power to the motor and the mechanical output of the motor through the gear system is connected to the wheel of the EV. A review of the issues related to the power quality that occurred while interfacing electric vehicles to the distribution system and various techniques to mitigate these problems have been done in [10]. In a grid reactive voltage regulation technique has been proposed that reduces the power losses enhances the stability

of voltage and optimizes the system to reduce the charging cost of EVs [11]. A low weight, size and cost single stage power conversion based single phase multifunctional integrated converter for EVs has been proposed in [12] with a power factor and total harmonic distortion of 0.9999 and 2.16% respectively. A hierarchical control design for frequency regulation of multi-area EV to grid application has been proposed in [13] and found that the V2G operation affected the primary control period more than the secondary control period. A battery management system based on automotive drive cycle measurements for lithium-ion batteries used in EVs has been proposed [14]. A new energy regeneration system for BLDC motor-driven electric vehicles has been proposed in [15] and found to increase the efficiency of the EV motor drives. Optimal scheduling of smart micro grids considering electric vehicle battery swapping stations has been proposed in [16] that reduces the overall cost of the system to 72 %. Salado *et al.* [17] proposed an electronic platform to include multiple energy harvesting devices in a fuel-cell hybrid electric vehicle was presented together with a multiple MPPT-EMS. Kalyanasundaram [18] proposed a two-stage battery charger for EV application has been proposed and validated in MATLAB simulation and compared with the existing model and found to have higher efficiency than traditional models. A new optimal scheduling methodology for micro-grid considering the battery energy storage systems, EVs and demand response-based teaching-learning-based optimization (TLBO) algorithm [19]. An efficient, cost-effective and sustainable grid-connected electric vehicles (EVs) battery charger based on a buck converter to reduce the harmonics injected into the mains power line has been proposed with an 88.1 % efficient charging prototype and a resultant sending-end power factor of 0.89 [20], [21]. The AC-DC conversion for EV application can be done by using a simple diode bridge rectifier as a front-end converter. To obtain refined DC output from the diode bridge rectifier, the capacitor is connected to the output terminals of the diode bridge rectifier. The use of an output capacitor causes power factor concerns creating the phase angle difference between the input source voltage and current. The conversion process diminishes the input source power factor which is a worrying factor and insists on power factor correction converter [22]–[26]. Poor power factor at the input of the charging system leads to over-sizing of electrical equipment, increase in conductor size and cost, poor voltage regulation and poor efficiency.

This paper addresses the power factor issue while charging the battery of EVs. The paper focuses on maintaining the unity power factor on the source side while charging the battery of the EV from AC-DC conversion. The model is developed and the results are discussed (for three different battery levels) using MATLAB/Simulink software.

2. ELECTRICAL VEHICLE CHARGING SYSTEM

The proposed design model of electric vehicle charging system is shown in Figure 1. The generally available source of electrical power is AC type and is the main source for EV as well. The available AC type of power supply is converted to a DC type to charge a battery of EVs. The onboard socket is provided for charging purposes. The AC type is tapped through the onboard socket to the diode bridge rectifier (DBR). DBR converts AC to DC type and to obtain refined DC output, a capacitor is connected at the output terminals of DBR. The capacitor output is fed to a DC-DC converter to regulate the voltage according to the requirement of the EV system as shown in Figure 1. The output of the DC-DC converter charges the battery of the EV.

Extinction and emission of carbon gases make conventional fuels limited in usage and give scope for research to look for alternative sources. Gasoline engine-based modes of transportation are the major constraint in the emission of greenhouse gases. Electric vehicles emitting zero pollution are a viable option for conventional engine vehicles. The trend illustrates that EVs replaces conventional engine vehicles in the mere future.

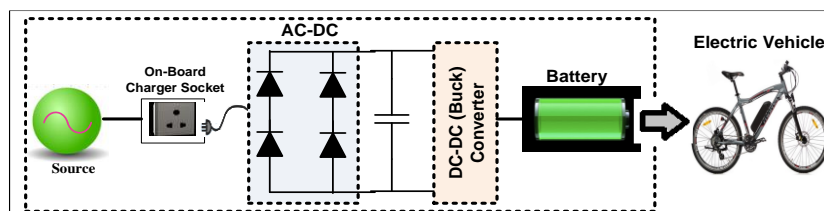

Figure 1. Proposed design model of electric vehicle charging system

3. BUCK DC-DC CONVERTER FOR BATTERY CHARGING

A buck converter is a simple DC-DC converter which gives out the reduced output voltage compared to the input voltage. Figure 2 shows the buck converter which consists of a switch, diode inductor

and a capacitor. Switching (buck) converter gives more efficiency than linear regulators. During the switch ON time of the buck converter, as shown in Figure 3(a), the switch is ON and the diode becomes reverse biased. The inductor is charged up to the input source level and the voltage across the inductor is given by (1). The current circulates from the input source to load through the inductor.

$$V_L = V_{out} - V_{in} \tag{1}$$

During the switch OFF time of the buck converter, as shown in Figure 3(b), the switch is OFF and the diode becomes forward biased. The input source is completely isolated since the switch opens and the stored energy in the inductor (1) is discharged to the load.

The duty cycle of the buck converter (in continuous mode) is given by (2).

$$V_{out} = D * V_{in} \tag{2}$$

The duty cycle formulation illustrates that as the duty cycle varies from 0 to 1, the maximum output that can be obtained will be equal to that of the input voltage or will be less than the input voltage.

Closed-loop circuit of the buck converter for the generation of control gate pulses for the power transistor is shown in Figure 4. The output actual voltage is compared to the reference voltage level and the error is fed to the PI controller to obtain the reference voltage signal which is then operated along with the carrier signal through a comparator to obtain controlled gate pulses to the power transistor in buck converter.

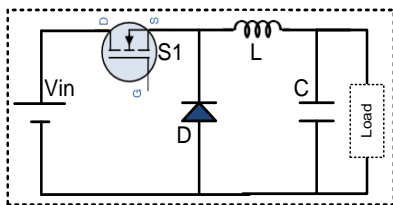

Figure 2. Buck converter

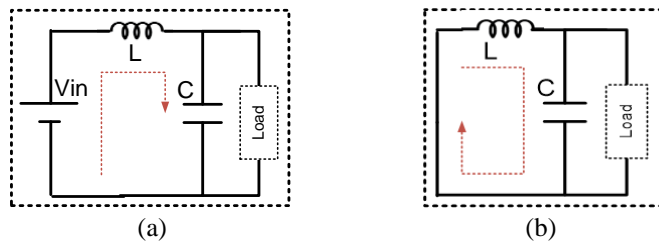

Figure 3. Buck converter switch at (a) ON condition and (b) OFF condition

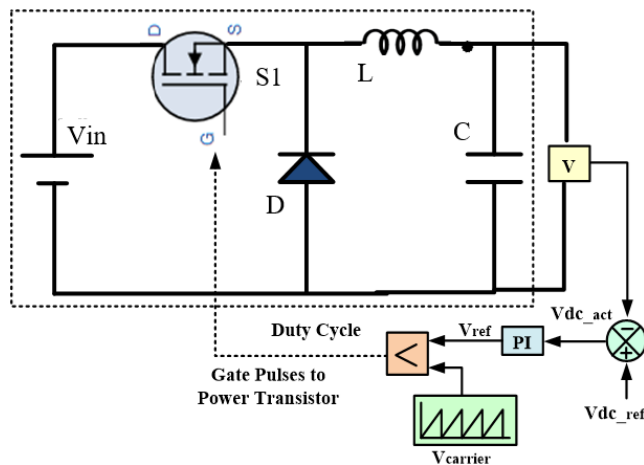

Figure 4. Closed-loop buck converter

4. AC-DC UNITY POWER FACTOR CHARGING FOR EV

The generally available source of electrical power is AC type and is the main source for EV as well. The available AC type of power supply is converted to a DC type to charge a battery of EVs. The onboard socket is provided for charging purposes. The AC type is tapped through the onboard socket to the diode bridge rectifier (DBR). DBR converts AC to DC type and to obtain refined DC output, a capacitor is connected at the output terminals of DBR.

As the presence of DBR deteriorates the source side power factor the control methodology to correct the source side power factor is shown in Figure 5. Battery actual voltage is compared with the reference value and the error signal is fed to the PI controller which gives out the current magnitude (input source side) signal. AC input source shape is sensed and is multiplied with the current magnitude signal to obtain the current reference signal. The current reference signal is compared with the actual current (from buck output) and the net signal is fed to Hysteresis current controller to generate the gate pulses to the power transistor in the buck converter. This process corrects the input current shape and hence maintains the input source side power factor unity.

The overall EV battery charging system with unity power factor correction is shown in Figure 6. The output of the DC-DC converter charges the battery of the EV. Closed-loop buck converter while regulating the voltage, also regulates the current signal and accordingly gate pulses are generated. Hence input (on the AC side) source power factor is corrected yielding a unity power factor.

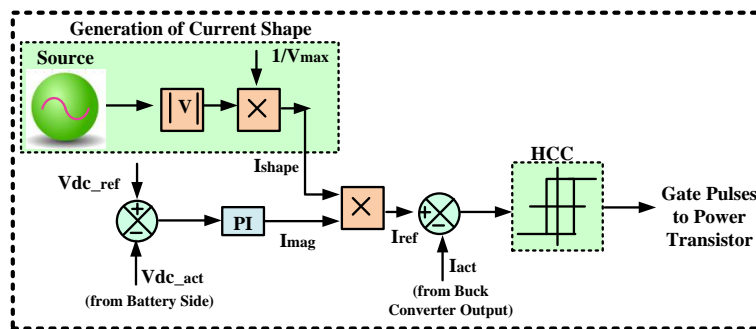

Figure 5. Control for unity power factor in EV battery charging system

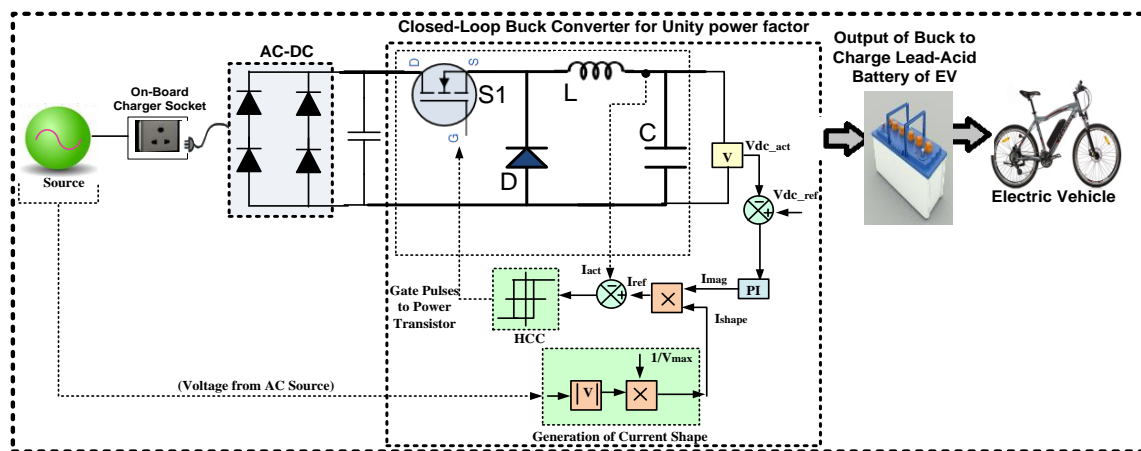

Figure 6. Overall EV battery charging system with power factor correction

5. RESULT ANALYSIS

Table 1 illustrates the system parameters used for simulation analysis. The different parametric values of the circuit used in the simulation of the AC-DC UPF charging circuit for two-wheeler electric vehicle application are described. A lead-acid type battery is used in the analysis for electric vehicle applications. The analysis is carried out for three different charging conditions of Lead-acid batteries for EV application.

Figure 7 represents the MATLAB simulation model in which the ac source is first converted to DC through an AC-DC converter using the above-mentioned switching strategy. The EV and battery are connected to a DC-DC buck converter with the proposed switching scheme which is connected to the AC-DC converter. The power flows from the AC source to the destination DC-DC converter that facilitates the charging of the battery connected to the EV. The simulation model has been designed in MATLAB 2015a for discrete variable steps with a sample time of 50e-6 and an ode45 solver.

Table 1. System parameters

Parameter	Value
AC source	1- \emptyset , 230V, 50Hz
Buck inductor	1mH
Buck capacitor	4500 μ F
Battery type	Lead-acid type
Battery rating	Nominal voltage (64V, 120V, 200V), 200Ah
Battery nominal discharge current	40 A
Battery SoC (%)	80 %
Battery response time	30 Sec

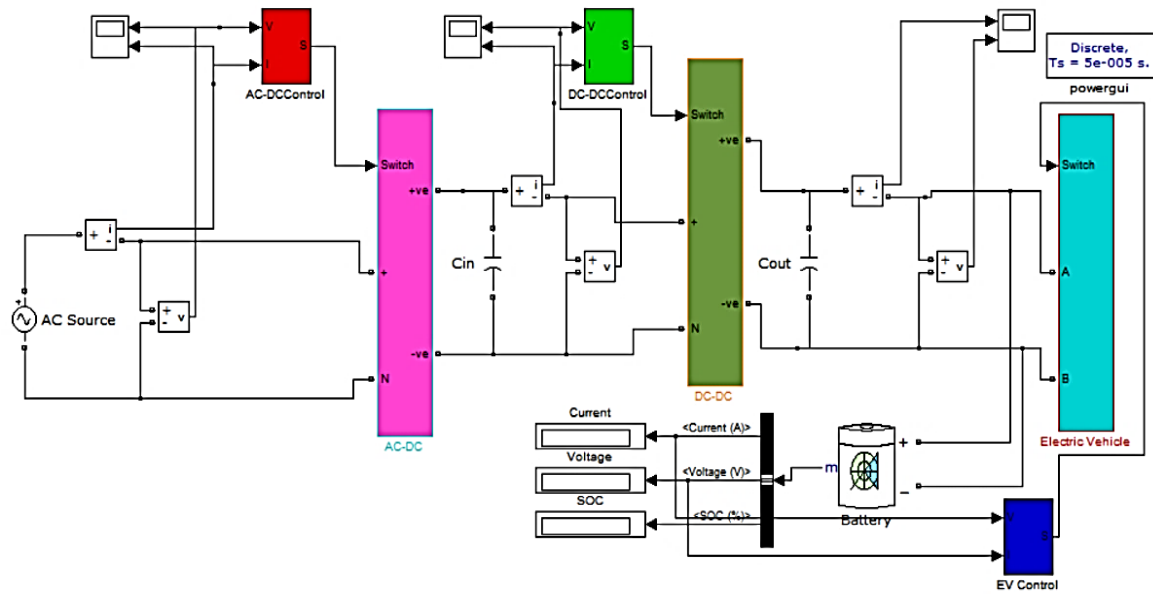

Figure 7. Simulation model of the proposed system

5.1. AC-DC unity power factor charging for 64 V battery

Figures 8 and 9 show the input source voltage and current on the AC side. The voltage is with 320 V peak amplitude and current with 2.75 A amplitude. Figure 10 shows the AC input source power factor. The input source voltage and current are in phase and yield a unity power factor. Figure 11 illustrates the FFT window of AC input source current and the AC source is distorted by 1.20% to fundamental. Figure 12 shows the state of charging (%) of the battery (charging for 64 V condition). The charging percentage is close to 80 % over the period. Figures 13 and 14 show the output voltage and output current of the battery. The battery output voltage is 61 V (full charge condition) and the current is negative 14.1 A in magnitude illustrating the battery is in charging mode.

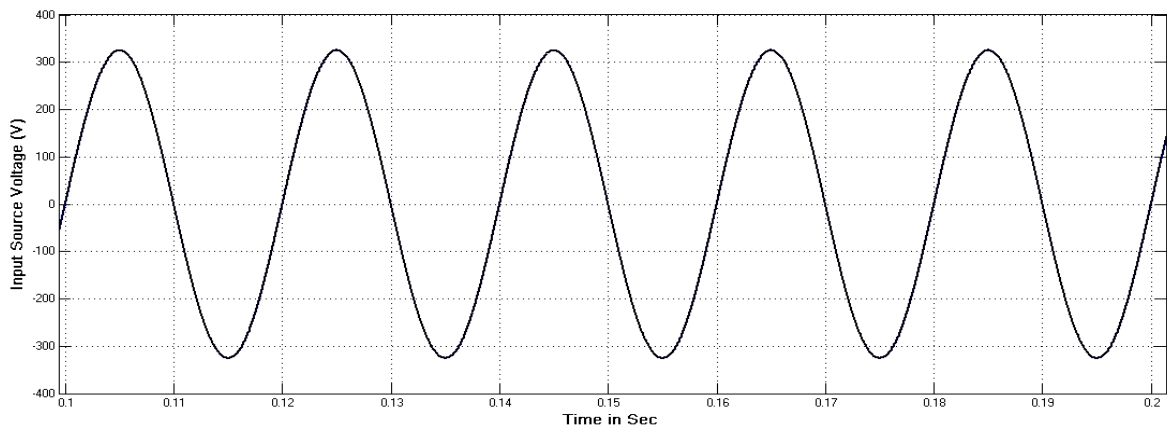

Figure 8. Input source voltage

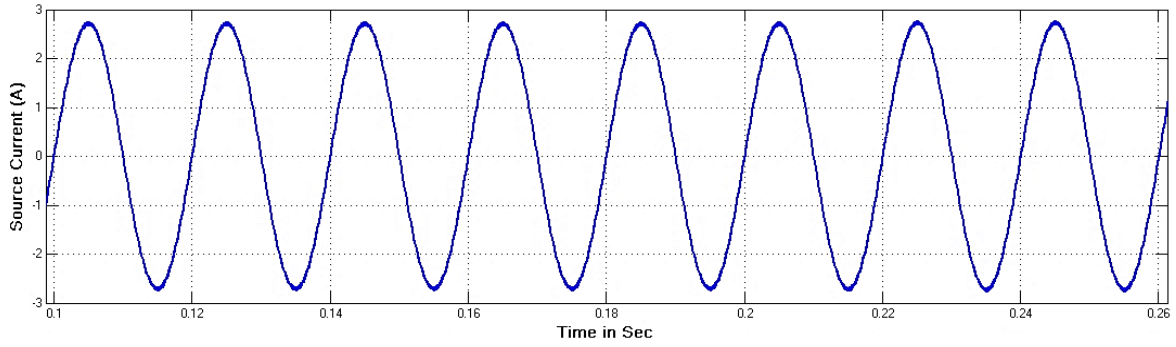

Figure 9. Input source current

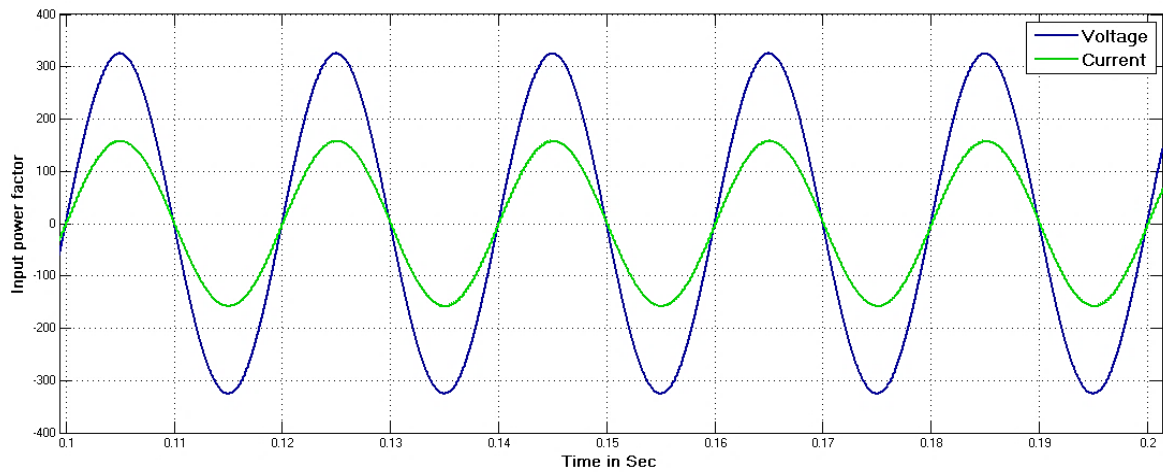

Figure 10. Input source side power factor

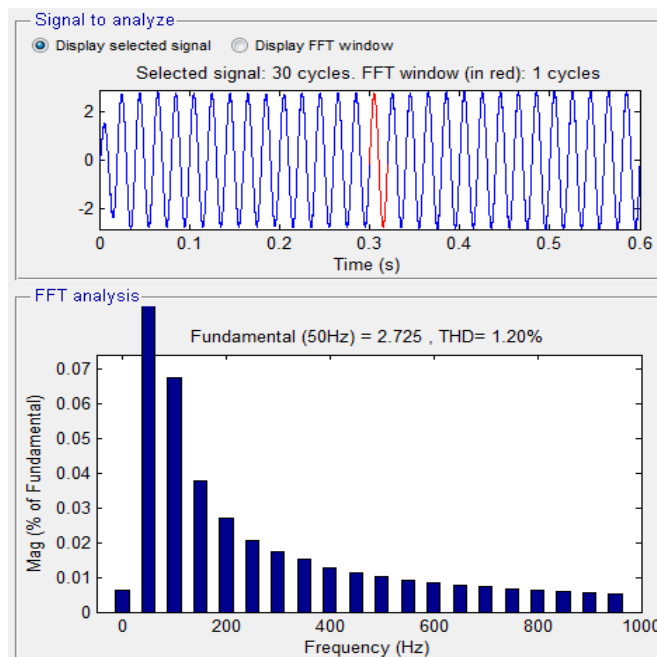

Figure 11. Input source current THD

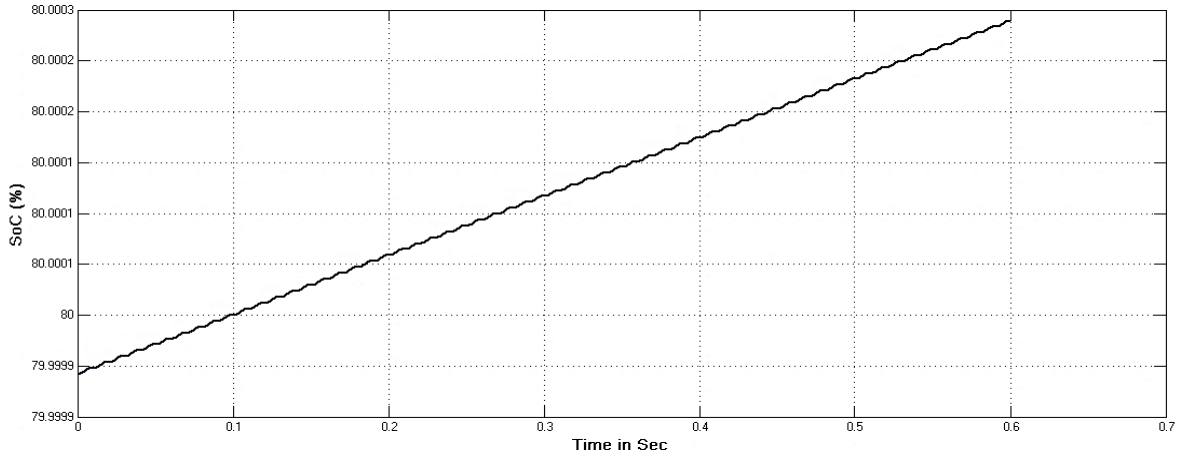

Figure 12. Battery state of charging (%)

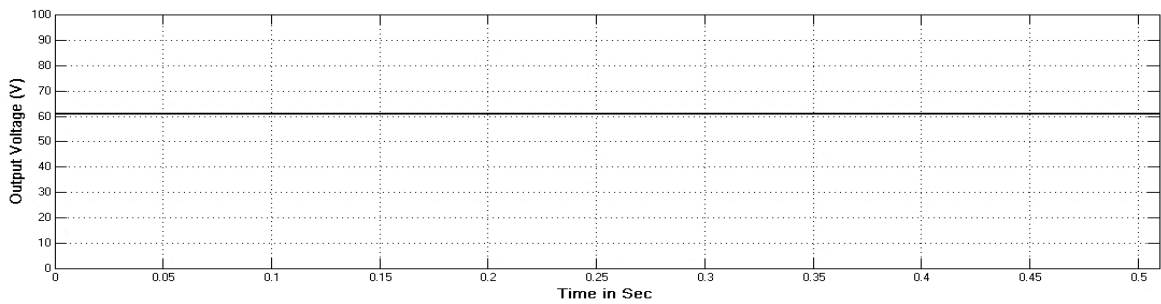

Figure 13. Output voltage of the battery

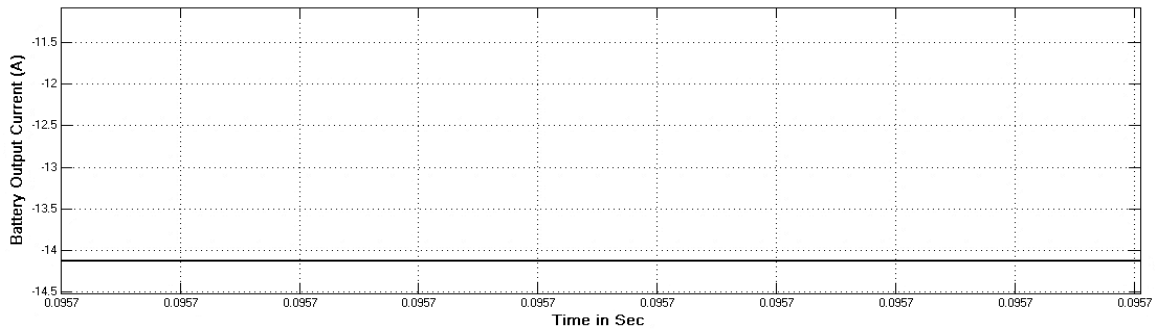

Figure 14. Output current of the battery

5.2. AC-DC unity power factor charging for 120 V battery

Figures 15 and 16 show the input source voltage and current on the AC side. The voltage is with 320V peak amplitude and current with 4 A amplitude. Figure 17 shows the AC input source power factor. The input source voltage and current are in phase and yield a unity power factor. Figure 18 illustrates the FFT window of AC input source current and the AC source is distorted by 0.85% to fundamental. Figure 19 shows the state of charging (%) of the battery (charging for 120 V condition). The charging percentage is close to 80% over the time.

Figures 20 and 21 show the output voltage and output current of the battery. The battery output voltage is 117 V (full charge condition) and the battery output current is negative 10.7 A in magnitude illustrating the battery is in charging mode.

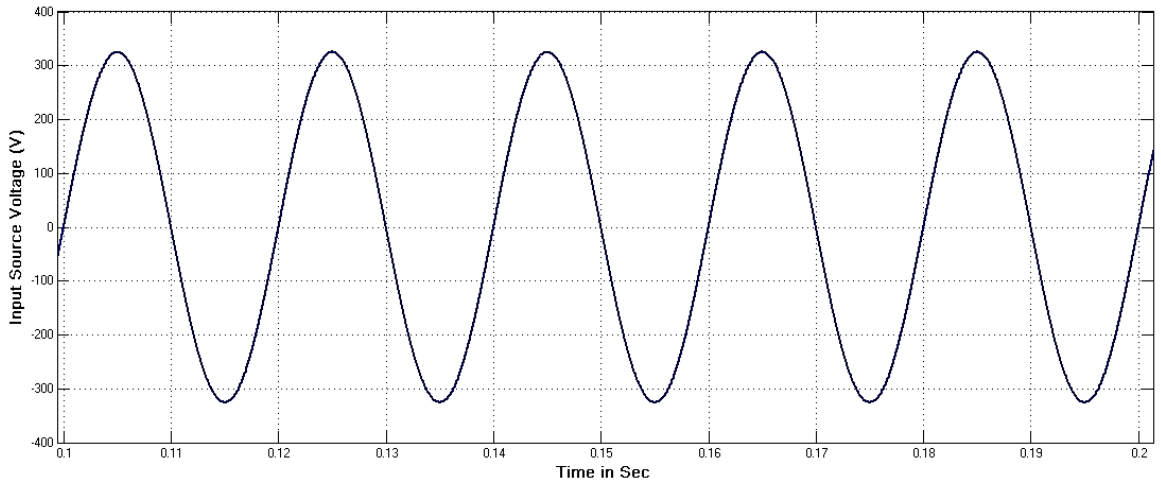

Figure 15. Input source voltage

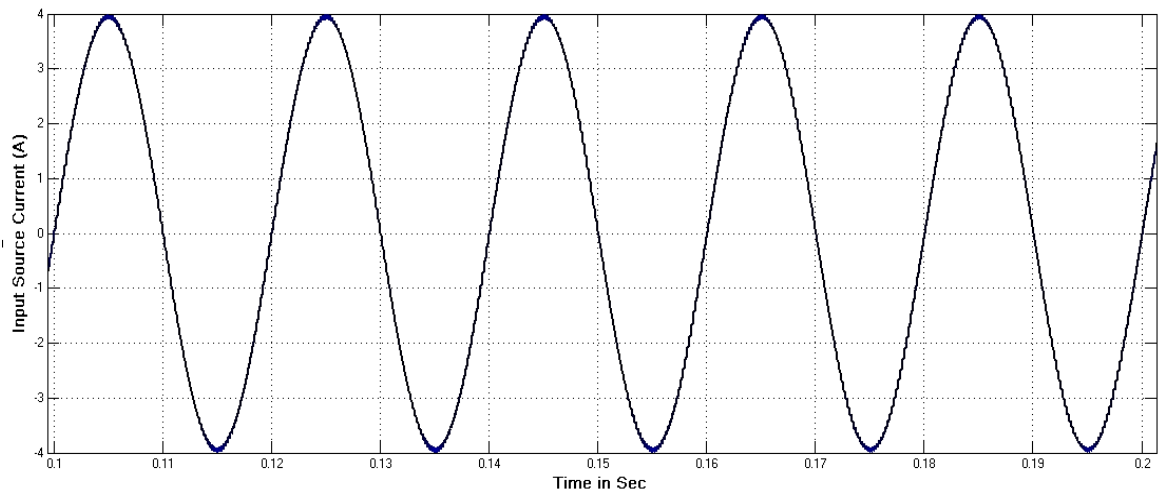

Figure 16. Input source current

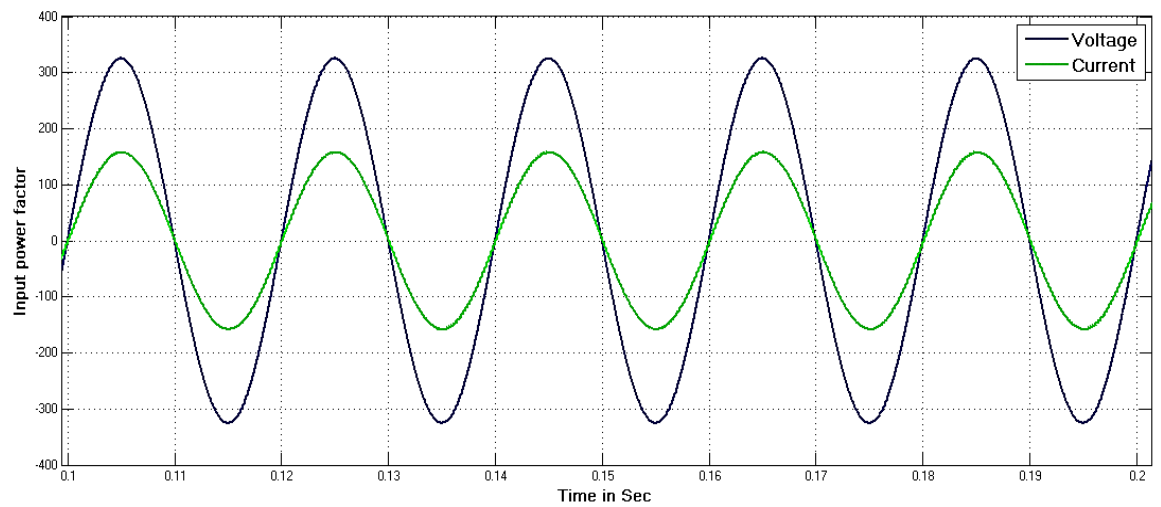

Figure 17. Input source power factor

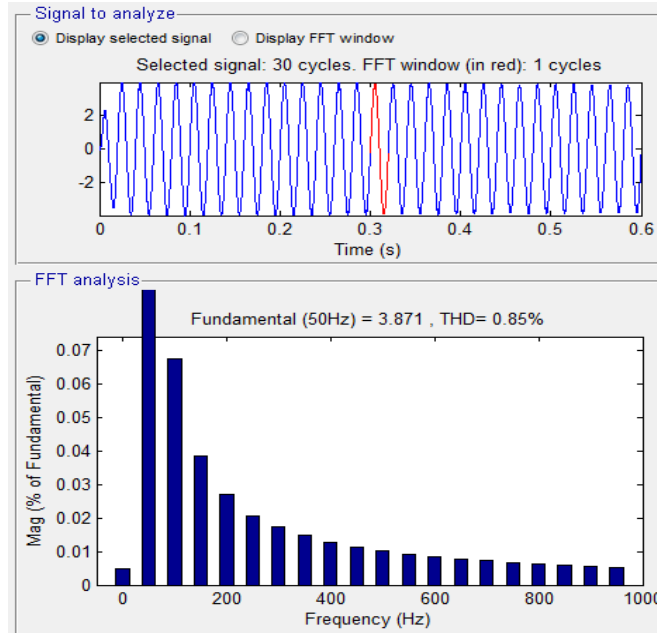

Figure 18. Input source current THD

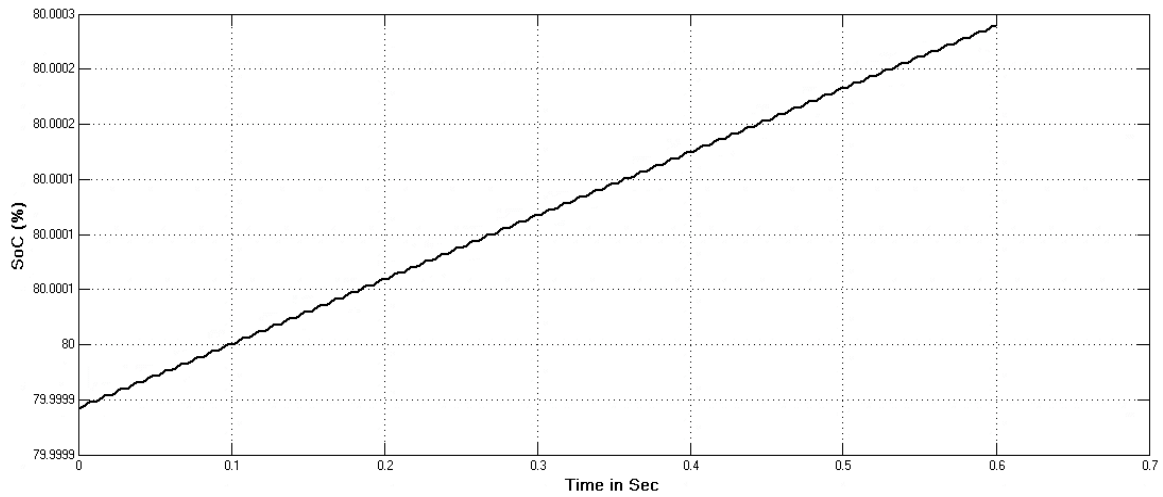

Figure 19. Battery state of charging (%)

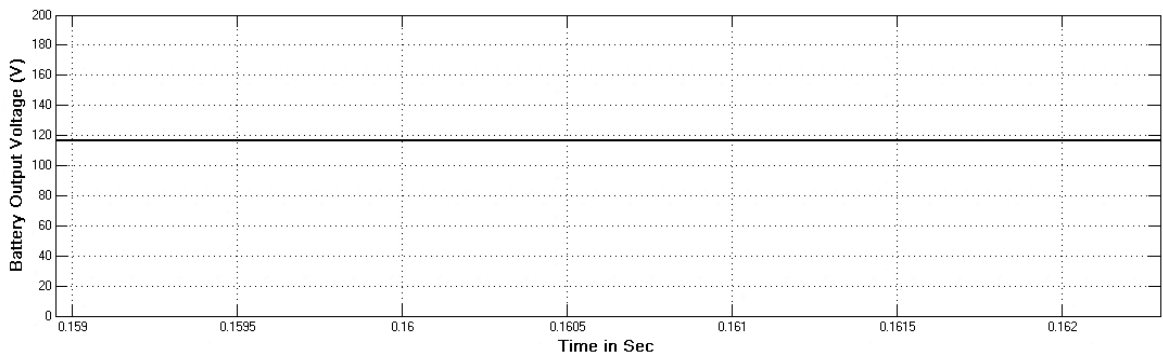

Figure 20. Output voltage of the battery

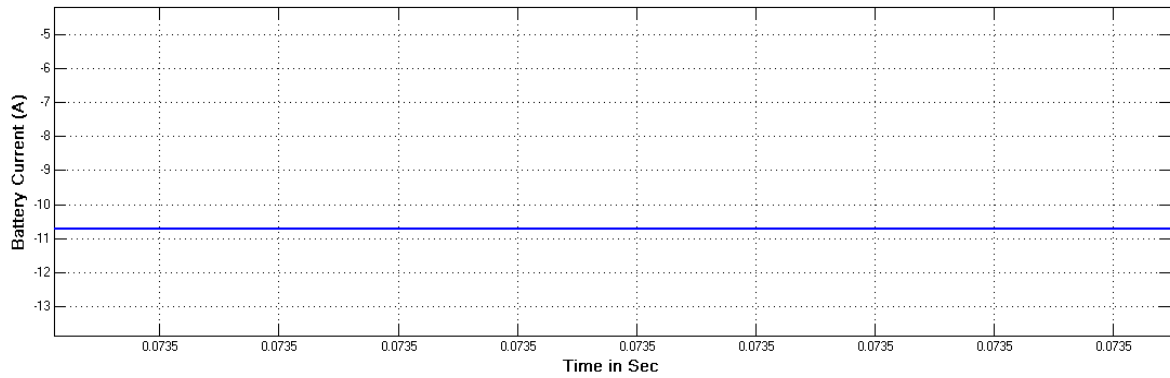

Figure 21. Output current of the battery

5.3. AC-DC unity power factor charging for 200 V battery

Figures 22 and 23 shows the input source voltage and current on the AC side. The voltage is with 320V peak amplitude and current with 2.5 A amplitude. Figure 24 shows the AC input source power factor. The input source voltage and current are in phase and yield a unity power factor. Figure 25 illustrates the FFT window of AC input source current and the AC source is distorted by 1.33% to fundamental. Figure 26 shows the state of charging (%) of the battery (charging for 200 V condition). The charging percentage is close to 80% over time.

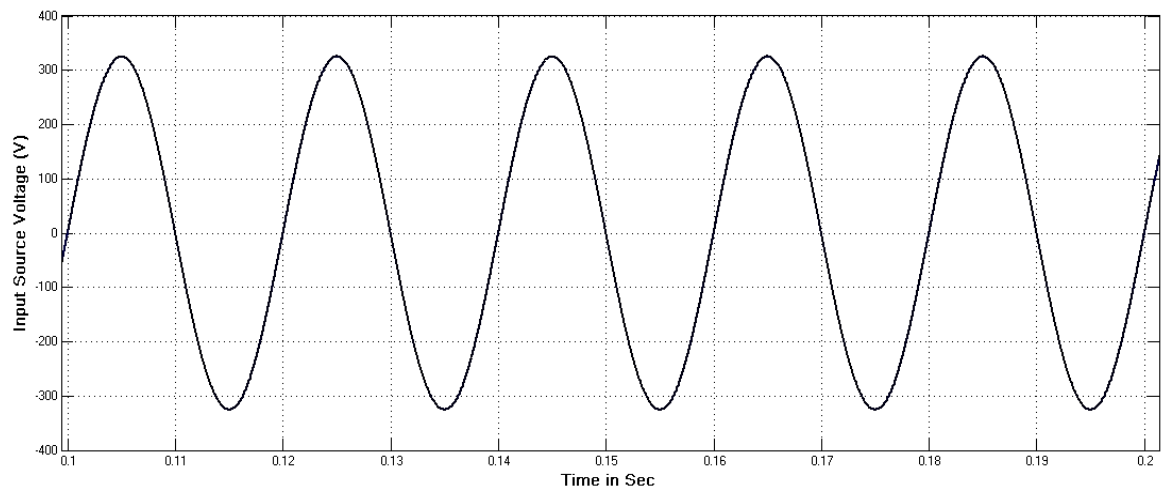

Figure 22. Input source voltage

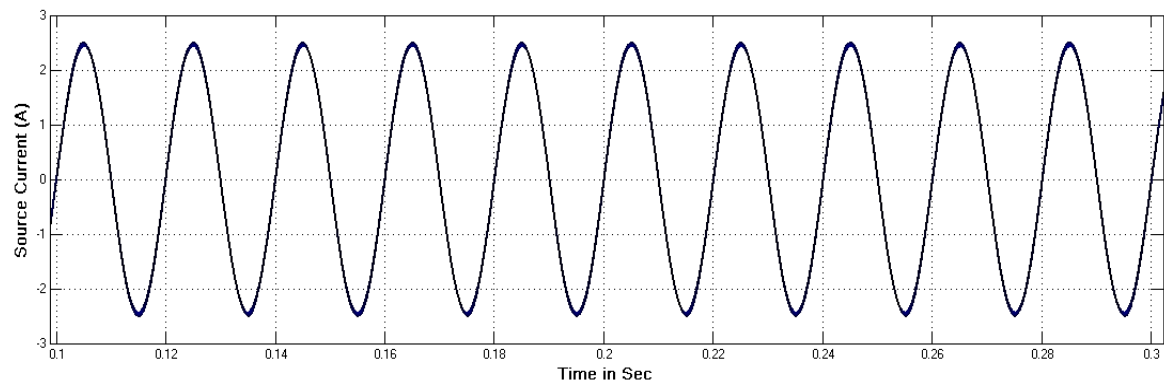

Figure 23. Input source current

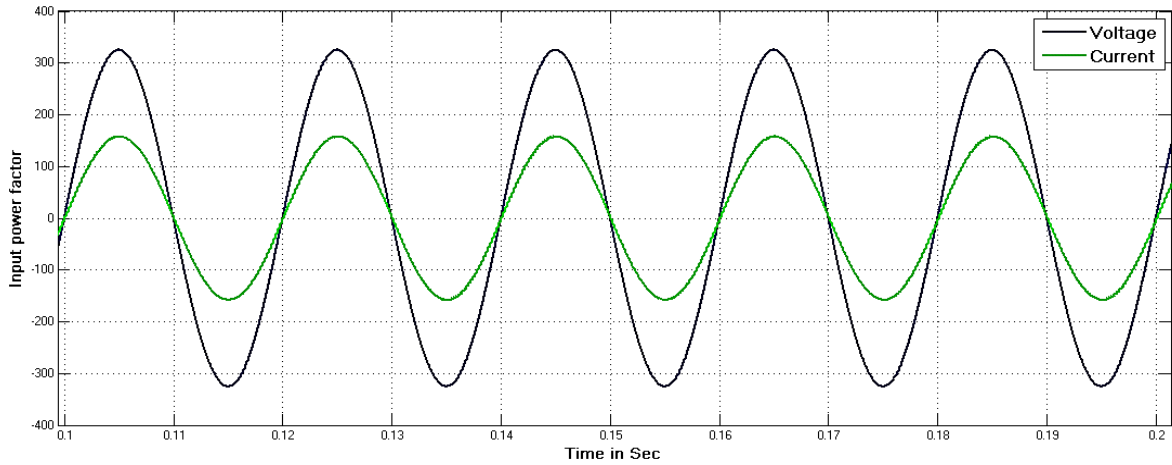

Figure 24. Input source power factor

Figures 27 and 28 show the output voltage and output current of the battery. The battery output voltage is 198 V (full charge condition) and the battery output current is negative 4.85 A in magnitude illustrating the battery is in charging mode. Table 2 describes the harmonic distortion in input source current for different battery conditions. In all three charging conditions of the battery, the input source current distortion is maintained within standard limits (less than 5%) illustrating the input source power factor will be unity.

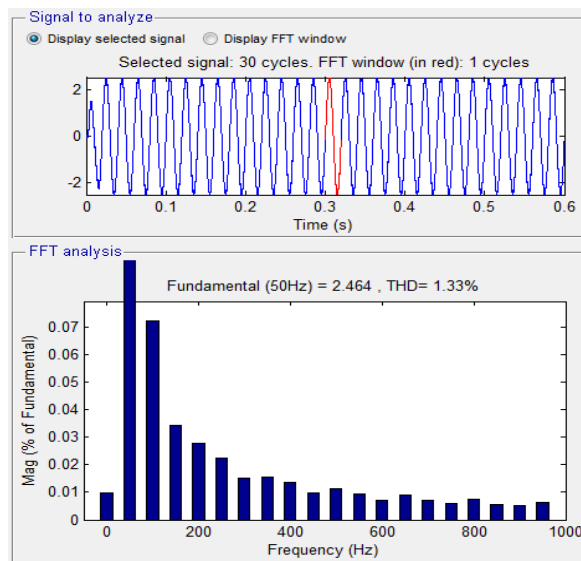

Figure 25. Input source current THD

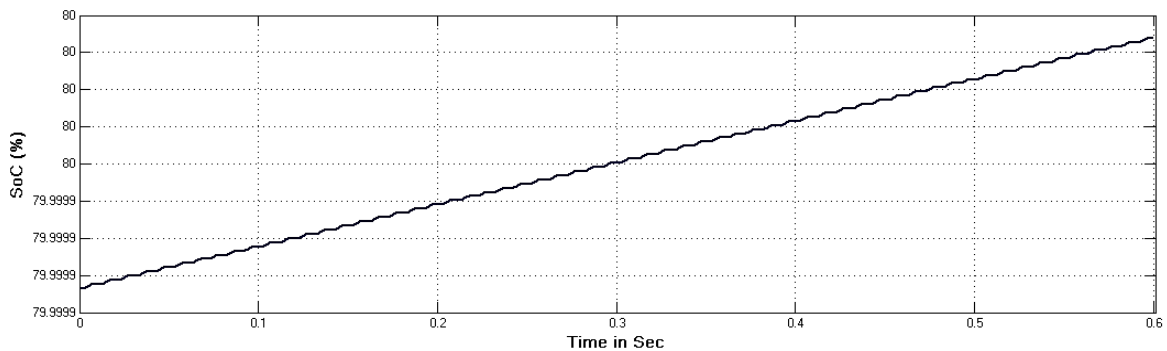

Figure 26. Battery state of charging (%)

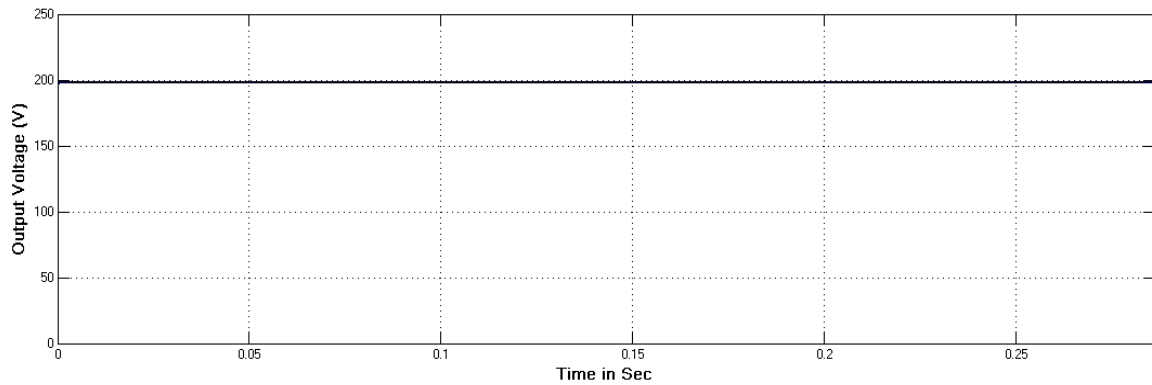

Figure 27. Output voltage of the battery

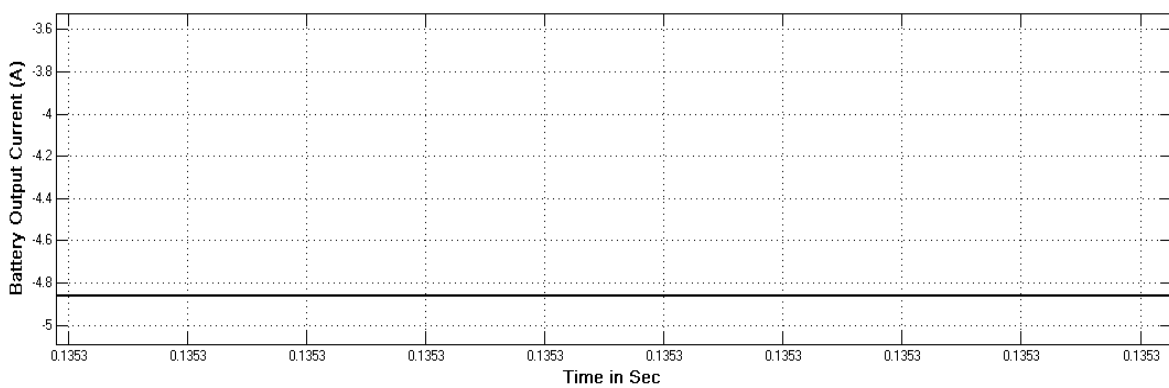

Figure 28. Output current of the battery

Table 2. THD in input source current

Battery condition	THD in source current
64 V	1.20%
120 V	0.85%
200 V	13%

6. CONCLUSION



Electric vehicles are trending these days replacing conventional gasoline engine vehicles. Gasoline engine vehicles emit greenhouse gases which deteriorate the environmental conditions and lead to global warming which is dangerous for living species. Charging technology and range of performance are the key factors in EV technology. Battery-driven EVs take AC supply and convert them to DC for charging the battery of the EV. During this process of conversion for battery charging, the input source current is distorted and goes out of phase to input source voltage diminishing the power factor. This paper addresses the battery charging system of EVs with a unity source power factor. THD in input source current is tabulated and the power factor for three different battery charging conditions is shown which illustrates that the power factor is almost unity on the source side. The AC power after converting to DC is fed to the battery for charging through the buck converter. The controlled buck converter improves the input source power factor and charges the battery for the EV.

REFERENCES



- [1] J. Y. Yong, V. K. Ramachandaramurthy, K. M. Tan, N. Mithulananthan, "A review on the state-of-the-art technologies of electric vehicle, its impacts and prospects," *Renewable and Sustainable Energy Reviews*, vol. 49, pp. 365–385, 2015, doi: 10.1016/j.rser.2015.04.130.
- [2] M. Yilmaz and P. T. Krein, "Review of Battery Charger Topologies, Charging Power Levels, and Infrastructure for Plug-In Electric and Hybrid Vehicles," *IEEE Transactions on Power Electronics*, vol. 28, no. 5, pp. 2151–2169, 2013, doi: 10.1109/TPEL.2012.2212917.

- [3] A. V. J. S. Praneeth and S. S. Williamson, "A review of front end AC-DC TOPOLOGIES IN UNIVERSAL BATTERY CHARGER FOR ELECTRIC TRANSPORTATION," *IEEE Transportation Electrification Conference and Expo (ITEC)*, 2018, pp. 293–298, doi: 10.1109/ITEC.2018.8450186.
- [4] S. S. Williamson, A. K. Rathore and F. Musavi, "Industrial electronics for electric transportation: current state-of-the-art and future challenges," *IEEE Transactions on Industrial Electronics*, vol. 62, no. 5, pp. 3021–3032, 2015, doi: 10.1109/TIE.2015.2409052.
- [5] W. M. S. W. Bukhari, S. F. Toha, R. A. Hanifah and N. A. Kamisan, "Speed analysis of motorcycle's wheel drive in various road conditions," *International Journal of Power Electronics and Drive Systems*, vol. 13, no. 1, pp. 30–38, 2022, doi: 10.11591/ijpeds.v13.i1.pp30-38.
- [6] M. Nivas, R. K. P. R. Naidu, D. P. Mishra and S. R. Salkuti, "Modeling and analysis of solar-powered electric vehicles," *International Journal of Power Electronics and Drive Systems*, vol. 13, no. 1, pp. 480–487, 2022, doi: 10.11591/ijpeds.v13.i1.pp480-487.
- [7] Z. Geng, T. Thiringer, Y. Olofsson, J. Groot and M. West, "On-board impedance diagnostics method of li-ion traction batteries using pseudo-random binary sequences," *20th European Conference on Power Electronics and Applications (EPE'18 ECCE Europe)*, 2018, pp. P.1-P.9.
- [8] J. Zhang, H. Yan, N. Ding, J. Zhang, T. Li and S. Su, "Electric vehicle charging network development characteristics and policy suggestions," *International Symposium on Computer, Consumer and Control (IS3C)*, 2018, pp. 469–472, doi: 10.1109/IS3C.2018.00124.
- [9] J. Zhang *et al.*, "A non-cooperative game based charging power dispatch in electric vehicle charging station and charging effect analysis," *2nd IEEE Conference on Energy Internet and Energy System Integration (EI2)*, 2018, pp. 1–6, doi: 10.1109/EI2.2018.8582445.
- [10] A. Tavakoli, S. Saha, M. T. Arif, M. E. Haque, N. Mendis, and N. Mendis, "Impacts of grid integration of solar PV and electric vehicle on grid stability, power quality and energy economics: A review," *IET Energy Systems Integration*, vol. 2, no. 3, pp. 243–260, 2020, doi: 10.1049/iet-esi.2019.0047.
- [11] C. Cao, Z. Wu and B. Chen, "Electric vehicle–Grid integration with voltage regulation in radial distribution networks," *Energies*, vol. 13, no. 7, pp. pp. 1–18, 2020, doi: 10.3390/en13071802.
- [12] K. S. Reddy nad S. B. Veeranna, "Single phase multifunctional integrated converter for electric vehicles," *Indonesian Journal of Electrical Engineering and Computer Science*, vol. 24, no. 3, pp. 1342–1353, 2021, doi: 10.11591/ijeecs.v24.i3.pp1342-1353.
- [13] P. Wirasanti and S. Premrudeepreechacharn, "Frequency regulation service of multiple-areas vehicle to grid application in hierarchical control architecture," *International Journal of Electrical & Computer Engineering*, vol. 11, no. 6, pp. 4597–4609, 2021, doi: 10.11591/ijece.v11i6.pp4597-4609.
- [14] J. Khalifi, N. Boumaaz, A. Soulmani, and E. M. Laadissi, "An electric circuit model for a lithium-ion battery cell based on automotive drive cycles measurements," *International Journal of Electrical and Computer Engineering*, vol. 11, no. 4, pp. 2798–2810, 2021, doi: 10.11591/ijece.v11i4.pp2798-2810.
- [15] R. Palanisamy, R. Sahasrabudhe, M. K. Hiteshkumar and J. A. Puranik, "A new energy regeneration system for A BLDC motor driven electric vehicle," *International Journal of Electrical and Computer Engineering*, vol. 11, no. 4, pp. 2986–2993, 2021, doi: 10.11591/ijece.v11i4.pp2986-2993.
- [16] J. G. Guarin, W. Infante, J. Ma, D. Alvarez and S. Rivera, "Optimal scheduling of smart micro grids considering electric vehicle battery swapping stations," *International Journal of Electrical and Computer Engineering*, vol. 10, no. 5, pp. 5093–5107, 2020, doi: 10.11591/ijece.v10i5.pp5093-5107.
- [17] J. G. P. Salado, L. F. G. Cárdenas, M. A. R. Licea, F. J. P. Pinal, "Harvesting in electric vehicles: Combining multiple power tracking and fuel-cells," *International Journal of Electrical and Computer Engineering*, vol. 10, no. 5, pp. 5058–5073, 2020, doi: 10.11591/ijece.v10i5.pp5058-5073.
- [18] V. Kalyanasundaram, G. S Fernandez, K. Vijayakumar, and S. Vidyasagar, "A two stage battery charger for EV charging applications," *Indonesian Journal of Electrical Engineering and Computer Science*, vol. 19, no. 2, pp. 593–599, 2020, doi: 10.11591/ijeecs.v19.i2.pp593-599.
- [19] S. R. Salkuti, "Solving optimal generation scheduling problem of Microgrid using teaching learning based optimization algorithm," *Indonesian Journal of Electrical Engineering and Computer Science*, vol. 17, no. 3, pp. 1632–1638, 2020, doi: DOI: <http://doi.org/10.11591/ijeecs.v17.i3.pp1632-1638>.
- [20] S. Das, K. M. Salim, D. Chowdhury, M. M. Hasan, "Inverse sinusoidal pulse width modulation switched electric vehicles' battery charger," *International Journal of Electrical & Computer Engineering*, vol. 9, no. 5, pp. 3344–3358, 2019, doi: 10.11591/ijece.v9i5.pp3344-3358.
- [21] P. Bhowmik, P. R. Satpathy, S. B. Thanikanti and N. Jana, "A novel virtual inertia emulation technique for the single phase electric vehicle charging topology," *Computers and Electrical Engineering*, vol. 101, 2022, doi: 10.1016/j.compeleceng.2022.108114.
- [22] T. Nussbaumer, K. Raggl and J. W. Kolar, "Design guidelines for interleaved single-phase boost PFC circuits," *IEEE Transactions on Industrial Electronics*, vol. 56, no. 7, pp. 2559–2573, 2009, doi: 10.1109/TIE.2009.2020073.
- [23] M. Pahlevaninezhad, P. Das, J. Drobnik, P. K. Jain and A. Bakhshai, "A ZVS Interleaved Boost AC/DC Converter Used in Plug-in Electric Vehicles," *IEEE Transactions on Power Electronics*, vol. 27, no. 8, pp. 3513–3529, 2012, doi: 10.1109/TPEL.2012.2186320.
- [24] U. Anwar, R. Erickson, D. Maksimović and K. K. Afridi, "A control architecture for low current distortion in bridgeless boost power factor correction rectifiers," *IEEE Applied Power Electronics Conference and Exposition (APEC)*, 2017, pp. 82–87, doi: 10.1109/APEC.2017.7930676.
- [25] F. Musavi, W. Eberle and W. G. Dunford, "A phase-shifted gating technique with simplified current sensing for the semi-bridgeless AC–DC converter," *IEEE Transactions on Vehicular Technology*, vol. 62, no. 4, pp. 1568–1576, 2013, doi: 10.1109/TVT.2012.2231709.
- [26] Y. S. Babu and K. C. Sekhar, "Five-phase induction motor drive for electric vehicle with high gain switched-inductor quasi impedance source inverter," *International Journal of Power Electronics and Drive Systems*, vol. 13, no. 1, pp. 411–422, 2022, doi: 10.11591/ijpeds.v13.i1.pp411-422.



BIOGRAPHIES OF AUTHORS

Swathi Karike    received B. Tech degree in Electrical and Electronics Engineering from JNTU Hyderabad in 2008, M.Tech degree in Power Electronics and Electric Drives from JNTU Hyderabad in 2012 and currently pursuing PhD in Electric Vehicles Charging Station area from Koneru Lakshmaiah Education Foundation, Vaddeswaram, Guntur. Her areas of interest include the field of power electronics, Application of Optimization in Power Electronics, Electrical Vehicles motor drives, industrial applications, and industrial electronics. She can be contacted at email: swathikarikephd@gmail.com.



Sudha Rani Donepudi    received B. Tech degree in Electrical and Electronics Engineering from JNTU Hyderabad in 2006, M.E. degree from Andhra University in 2008, Visakhapatnam, and Doctoral degree from National Institute of Technology Warangal in 2016. Currently working as Professor in Sri Vasavi Engineering College, West Godavari, Andhra Pradesh. Her areas of interest are Power System Automation, Smart Grid, Application of Optimization in Power Systems, and Electrical Vehicles. She can be contacted at email: lakshmisudha124@gmail.com.



Kuthuri Narasimha Raju    has done his BTech from Acharya Nagarjuna University in 2002, MTech in Power Electronics and Industrial Drives from JNTUH in 2012 and PhD from K L Deemed University in 2018. Presently working as Professor of EEE Department and Associate Dean IQAC (Internal Quality Assurance Cell) at K L deemed University. He was the former Head of the Department. He has published 20 Scopus indexed journals and presented papers in 10 international conferences including, TENCON 2015 at Macau China. His research interests include PWM techniques for Switched mode converters, Novel Multilevel inverter topologies, DC-Microgrid and Algorithms for determination of SOC, SOH and SOL for Energy storage devices used in Electric Vehicles and power systems. Presently he is guiding 8 Research Scholars and has successfully supervised 8 PG thesis. He has been presented with Uttam Acharya Award for the year 2019 by Indian servers and received Best teacher award for Academic years 2012–2013 and 2016–2017 at K L Deemed University. He can be contacted at email: Narsimharaju_eee@kluniversity.in.