

Novel control of PV-wind-battery powered standalone power supply system based LSTM based ANN

Yerragolla Hazarathaiyah^{1,2}, B. Venkata Rami Reddy²

¹Department of Electrical Engineering, JNTUA College of Engineering, Ananthapuramu, India

²Department of Electrical and Electronics Engineering, G. Pullaiah College of Engineering and Technology, Kurnool, India

Article Info

Article history:

Received Jun 16, 2023

Revised Nov 21, 2023

Accepted Dec 7, 2023

Keywords:

MPPT

Photovoltaic

Power quality

Standalone system

Wind

ABSTRACT

Integrated wind-photovoltaic (PV) based standalone electric power supply systems are widely used for various applications. A battery storage system is needed to provide continuous power supply to loads despite changes in loads, wind speed, and solar irradiance. Power quality is crucial in these hybrid systems, as the battery needs to charge from surplus power when generation exceeds the load and discharge to meet load demand. A bidirectional DC to DC converter is used to connect the battery to the network, and maximum power point tracking devices with proper algorithms are incorporated for optimal utilization of PV and wind turbines. Multiple PV systems and wind turbines are considered for proper power supply system ratings. Long short-term memory (LSTM) based artificial neural network (ANN) controllers are implemented for various control units in the hybrid standalone power system. The proposed control techniques improve power quality under various situations. Results are presented using MATLAB/Simulink to evaluate the performance of the proposed method.

This is an open access article under the [CC BY-SA](https://creativecommons.org/licenses/by-sa/4.0/) license.



Corresponding Author:

Yerragolla Hazarathaiyah

Department of Electrical Engineering, JNTUA College of Engineering

Ananthapuramu, India

Email: hazarathaiyahpcet2015@gmail.com

1. INTRODUCTION

Renewable energy sources powered standalone power supply systems are increasing day by day to reduce pollution [1]–[3]. Integrating of a greater number of renewable sources can make system more reliable. Generation of electricity from wind and solar energy is the best procedure to make eco-friendly nature. Generally photovoltaic (PV) modules are required for converting solar energy into electricity and wind turbines are used to produce mechanical power from wind velocity. Permanent magnet synchronous generators (PMSGs) are using to convert this mechanical force to electrical power in medium power applications. Hence, a locally placed hybrid PV-wind energy based standalone power supply system is more popular worldwide [4], [5]. Even the integration of PMSG based wind and PV systems can make system more reliable but energy storage system must be used in standalone systems to maintain power balance as well as to supply stable power to consumers under variations in wind speed, solar irradiance, and load [4], [5]. Despite the fact that there are numerous energy storage devices, batteries are the best since they respond quickly throughout the charging and discharging processes [4]. Therefore, a battery bank is considered in this paper to make system more reliable and stable during various operating conditions. Further a DC-to-DC bidirectional converter is used to maintain charging and discharging process of the battery depending on power difference between generation and load.

Generally maximum power point tracking (MPPT) converters along with proper algorithms needs to be used on both wind turbines and PV panels to achieve their best utilizations [5]–[7]. Hence, boost converters are integrated at appropriate places in the hybrid standalone power generation system to use as MPPT converters. The energy balance between generation and load is achieved by regulating voltage at DC-link through the bidirectional DC to DC converter. An inverter with proper controlling mechanism is required to operate AC loads from DC-link. Moreover, single phase loads are operating in distribution system which leads unbalanced voltages at three phase terminals [4]–[7]. Available surplus power will be dumped into batteries; hence the battery voltage should be maintained less than the voltage at DC-link for making fastest charging process. Similar way, battery bank needs to be discharge for satisfying deficiency of power from generation when connected more load. Therefore, a boost operation is required while discharging the battery.

Variations in voltage at DC-link can be reflected from power difference between generation and load [7]. Therefore, the control of bidirectional DC to DC converter is designed to maintain power balance by compensating the power difference through battery. The inverter can able to regulate voltage at AC bus once maintained stable voltage at DC-link. However, always consumers required quality power from supply, hence proper control of inverter is required to provide quality supply at load bus. A stable AC voltage needs to be maintained at point of common coupling (PCC) under unbalanced load, sudden changes in the load and random changes of irradiance as well as wind velocity.

Generally conventional proportional-integral (PI) controllers cannot perform well during rapid changes in the power system due to design them with fixed gains. Hence, artificial neural network (ANN) based controllers needs to be adopted while designing the control techniques for converters used in the standalone system. However, long short-term memory (LSTM) based ANN system can provide better response with less time during unknown interference signals. Therefore, LSTM based deep learning algorithm is developed while designing ANN controllers for controlling techniques for various converters in this paper. The designed ANN controllers are adopted in controlling techniques to regulate both the voltages at DC-link as well as AC bus.

Further organization of this paper is arranged by: i) Providing system description in section 2; ii) Proposed control schemes by using LSTM based ANN controllers are explained in section 3; iii) In section 4, many findings are displayed with the aid of the MATLAB software; and iv) Section 5 contains the conclusion, which is condensed with system ratings.

2. SYSTEM DESCRIPTION

A single wind system and a single PV array are not sufficient to produce required power with stable voltage for long term. Number of PV modules needs to be arranged in the combination of series and parallel to maintain sufficient voltage and power rating of the PV system. Each wind turbine is employed with PMSG system to generate electricity. A diode rectifier is used to converter power generated from PMSG to DC power. A boost converter with proper controlling algorithm is associated after diode rectifier to connect the wind system to common DC-link. Numbers of wind systems are considered based on requirement of power rating. Parameters of a single wind system as well as PV module are provided in Table 1. Every PV group consists of their own MPPT device to obtain more energy. Similar to this, each wind system has its own MPPT converters embedded into it. A bidirectional DC to DC converter connects the battery bank to DC-link in order to keep the voltage there stable. Since each MPPT converter is uniquely connected to the DC-link using its own control method. Therefore, all MPPT devices are working for extract maximum energy irrespective of wind velocity and solar irradiance. This situation can give a chance to DC-to-DC bidirectional convert for regulating voltage at DC-link.

The DC power is converted to AC power for AC load through an inverter and filter is also considered between inverter and load bus. Combination of single, three phase loads with the nature of nonlinear are usually operated at AC bus [7]. Therefore, a four-wire system is considered in this paper to satisfy various loads. Figure 1 depicts the model configuration of a freestanding hybrid PV-wind-battery-based power supply system [8]–[10]. The implementation of modelling for wind turbines, PMSGs, batteries, PV modules, and filters is found [11]–[13]. Numerous researchers have proposed and carried out similar types of research in a variety of settings; only a handful of them are covered in this section. A hybrid PV, wind, and battery based standalone power supply system is implemented by Malla *et al.* [1]. Habib *et al.* [3] implement the ideal site for a system of energy management. Pradhan *et al.* [4] created a brand-new MPPT approach that allows PV systems to function in hybrid standalone power supply systems with partial shade.

Malla *et al.* [12] presented a freestanding PV-based power system but did not take wind power into consideration. Although Takagi-Sugeno (TS)-fuzzy based controller for PV-diesel-battery system hybrid system was proposed by Malla and Bhende [8], there is a diesel generator that is harmful to the environment. Bhagiya and Patel [13] created a double loop PI controller for a freestanding PV-based DC to DC converter.

Manisha *et al.* [14] propose a comparative analysis on nonlinear controller in PV-based standalone system. However, authors are not considered multiple power generations systems to establish common DC-link and also not implemented LSTM based ANN controllers. In general, nonlinear loads are connected to PCCs, which might introduce harmonics into other loads. In order to lessen the impact of nonlinear loads, active power filters and DSTATCOMs are required [15], [16]. Narayanan *et al.* [17] create a smart grid while taking into account a variety of renewable energy sources.

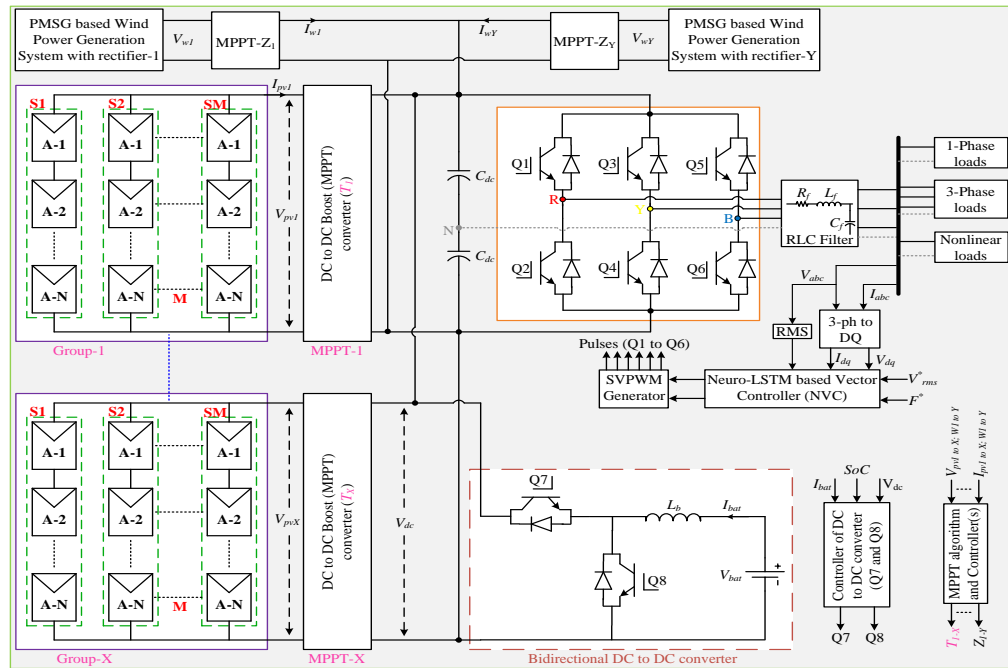

Figure 1. PV-wind-battery based standalone power supply system

3. CONTROL OF VOLTAGE AT DC-LINK AND INVERTER

Due to non-uniform of irradiances are received by PV groups, the converters for MPPTs cannot produce same voltage at output terminals. In the similar manner, all wind turbines cannot operate at same wind speed. Hence boost converter type MPPT converters can help to make common DC-link by connecting all MPPTs. However, the voltage at DC-link will be controlled by DC to DC converter by managing charging and discharging process of the batteries. Generally, ANN based controllers can exhibit superior performance than PI controllers during rapid changes in the system. Hence, LSTM based ANN controllers are designed in this paper to use in control schemes of voltages at both DC and AC bus. Further a deep learning algorithm is introduced to update all weights of the ANN controllers. The LSTM designed model is depicted in Figure 2. The complete design of LSTM based ANN controller is shown in Figure 3.

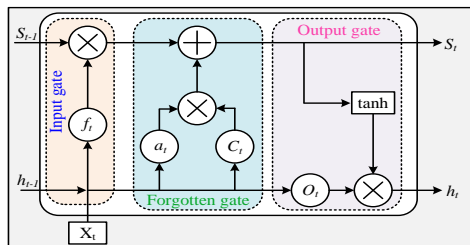

Figure 2. LSTM layout with memory cell

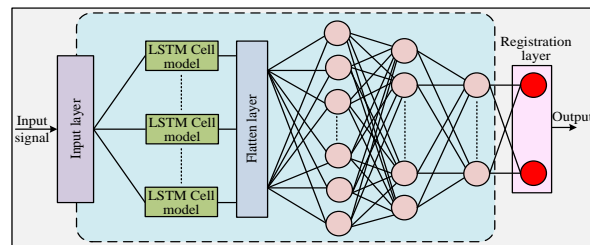

Figure 3. LSTM based ANN controller

The equations of the parameters $a_t, f_t, O_t, \hat{C}_t, s_t$ and h_t finding by using the (1)-(6). Major loads operated at AC bus are single phase consumptions as well as nonlinear in nature. These kinds of loads will

create unbalance in three phases as well as impose ‘ 2ω ’ frequency oscillations into the voltage at DC-link [17]. These oscillations will create shaking affect in wind turbines as well as can causes to produce heat at the terminals across PV panels. Hence, in order to minimize the effect from oscillations in DC-link, the DC-link control method is proposed in such a manner that those oscillations should be circulated through DC to DC converter and battery [18]. He proposed control method of the DC to DC converter is presented in Figure 4 [19].

$$a_t = \sigma(b_a + h_{t-1} \times w_{ah} + X_t \times w_{ax}) \tag{1}$$

$$f_t = \sigma(b_f + h_{t-1} \times w_{fh} + X_t \times w_{fx}) \tag{2}$$

$$O_t = \sigma(b_o + h_{t-1} \times w_{oh} + X_t \times w_{ox}) \tag{3}$$

$$\hat{C}_t = \tanh(b_c + h_{t-1} \times w_{ch} + X_t \times w_{cx}) \tag{4}$$

$$s_t = f_t \otimes s_{t-1} + \hat{C}_t \times a_t \tag{5}$$

$$h_t = \tanh(s_t) \otimes O_t \tag{6}$$

Variations will occur in DC-link when there is mismatch between generation power and load power [20], [21]. Based on this principal, the control scheme of DC-to-DC converter is developed by considering constant reference signal of DC-link voltage [22]. In Figure 4, the error signal between voltage at DC-link and its references is given to LSTM based ANN controller to generate battery reference current. Oscillating component (i.e., ‘ 2ω ’ oscillations) in voltage at DC-link is obtained by using low pass filter (LPF) and compared with zero to suppress it from DC-link through proposed controller. The reference battery current is further compared with actual battery current to generate required pulses through hysteresis loop. Therefore, the proposed control method is help to circulate ‘ 2ω ’ component through DC to DC converter. Further, the state of charge (SOC) is included in the design of control scheme to protect the battery from over charging and discharging. An inverter with proper control scheme is required to convert DC to AC [23]. The modulation index of the PWM can be decided the output voltage of the inverter once stabilized the voltage at DC-link. LSTM-ANN controllers based proposed control scheme is depicted in Figure 5 [18]. The frequency should be maintained in standalone system. Significant variations in active power mismatch can reflect on frequency of the AC output. As a result, the LSTM-ANN controller generates the reference component of the direct axis current using the frequency error signal from its reference [24]. Similarly, the root mean square (RMS) voltage is also compared to its reference for generating reactive component of current [25]. Required signals for switches are generating through a space vector pulse width modulation (SVPWM) process as depicted in Figure 6.

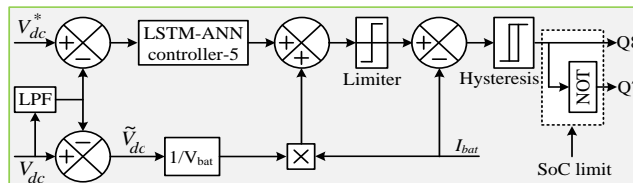

Figure 4. Proposed control system

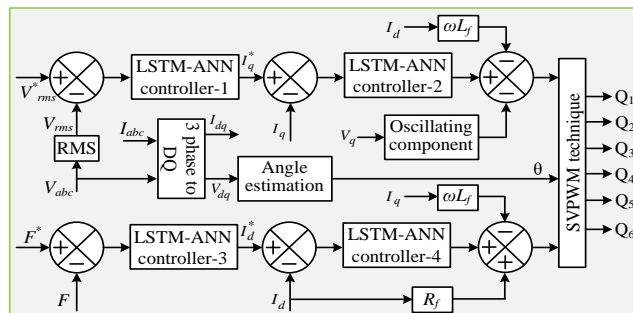

Figure 5. LSTM-ANN controller based proposed control scheme for inverter

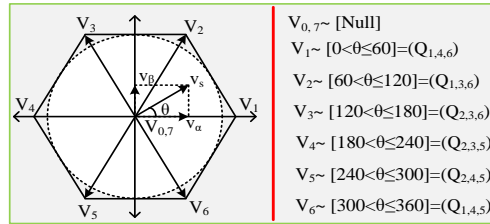

Figure 6. SVPWM technique

4. RESULTS AND DISCUSSION

MATLAB package is generally used to simulate power system models which can exhibits similar performance of real time systems. The PV system is modeled y connecting number of modules in the combination of series and parallel with the help of basic mathematical modeling. Similarly, 100 wind systems are considered to present the results in this section. Major components are collected from Simulink library functional blocks. The system is designed in discrete mode version with sample time of 20e-6. Various scopes are connected to obtain corresponding results. The designed model in MATLAB/Simulink is results obtained from the model are listed in below case studies.

4.1. Case-1: Performance under changes in generation and load

Total power of all PV systems is added to represent a single PV power while presenting the results. Similarly, total power of all wind systems is represented by wind power. Changes in powers of PV and Wind systems are reported in Figure 7(a) along with changes of power demanded by loads at AC bus. According to power mismatch between load and total generation, battery bank will act as compensator to maintain power balance in the system. Negative power of battery represents the process of charging and positive indicates the discharging action of the battery to make counter compensation towards load. Figure 7(b) illustrates the corresponding voltage across the dc-terminals (i.e., DC-link) that the battery can control. Due to variations in the load power, there are significant dips and spikes in voltage at DC-link; however, these are relatively nominal in comparison to its reference (i.e., 720 V). Under this scenario, respective RMS voltages of 3-phase is depicted in Figure 7(c). The stable responses are obtained by proposed control methods by using LSTM-ANN. However, instantaneous currents can give more realistic picture for the performance of the proposed control methods, hence 3-phase instantaneous load currents are provided in Figure 8.

4.2. Case-2: Performance under operation of unbalanced load

Most of the loads operated in home which are connected in distribution system are single phase. Hence it will lead unbalanced load operation in three phase power supply system. Due this issue, voltages at AC bus become unbalanced. The profile of three phase unbalanced load which is considered in this case is depicted in Figure 9(a). The worst scenario of load profile is considered to test the performance of proposed inverter controller in this case. The proposed control of inverter needs to be maintained constant three phase voltages at load bus to improve power quality. Corresponding phase RMS voltages at AC bus are shown in Figure 9(b). During sudden changes at load bus reflected sudden changes in load current slightly and becoming constant at its reference voltage (231 V).

If the Table 1 is the details about parameters of 0.5MW PV system. Table 2 show the parameters of two mass drive train (parameters of single wind-PMSG system) [19]-[20]. Table 3 show the parameters of PMSG system. By considering proper rating of voltage and power, the ratings of batteries are designed and the numerical calculations are given for a simple example in this section. The operating time period for discharging of the battery is considered as primary aspect to identify the rating f battery. In this paper, considered 480.0 V of battery bank and designed it for backup of 72.0 hours with an average load of 0.5 MW at PCC. The current rating (Ah) of batteries is estimated from below expression at 0.6 SoC.

$$I_{bat} = \frac{5,00,000 \times 72}{480 \times 0.6} = 125 \text{ kAh}$$

Table1. Parameters of 0.5 MW PV system

S.No	Parameter(s)	Rating	S.No	Parameter(s)	Rating
1	Current when short-circuit	8.01 A	Combinations for series and parallel of 0.5 MW		
2	Open-circuit terminal voltage	36.9 V	5	'N' in string	21
3	Voltage at MPP (V_{mpp})	30.3 V	6	'M' in group	7
4	Current at V_{mpp}	7.10 A	7	'X' in PV system	16

Table 2. Parameters of two mass drive train

Table 3. Parameters of PMSG system

S.No	Parameter(s)	Parameter(s)	Ratings	Parameter(s)	Ratings
H_t	4s	Number of poles	10	Stator inductance (L_s)	8.4 mH
H_g	$0.1H_t$	Rated speed	153 rad/s	Rated torque	40 Nm
K_{sh}	0.3 p.u./el.rad	Armature resistance (R_s)	0.425 Ω	Rated power	6.4 kW
D_t	0.7 p.u.s/el.rad	Magnetic flux linkage	0.433 Wb		

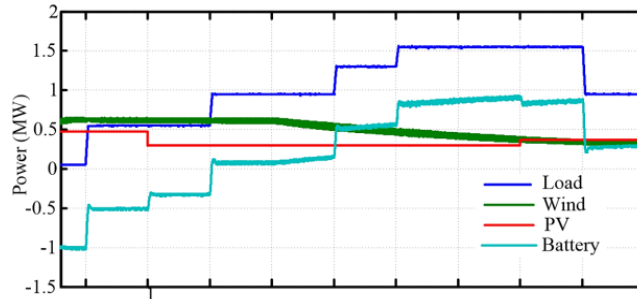

(a)

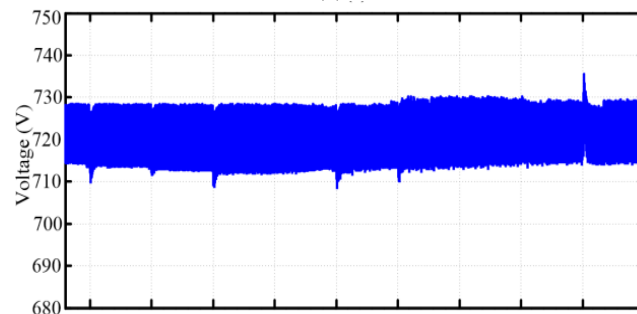

(b)

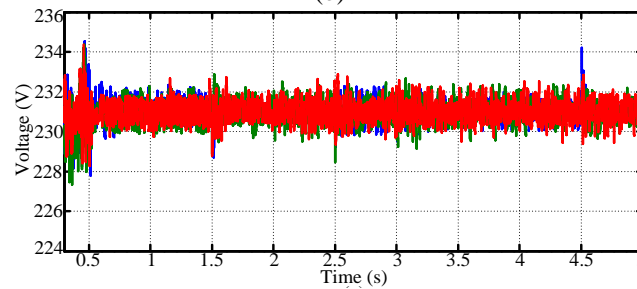

(c)

Figure 7. Performance under changes in generation and load: (a) various powers, (b) voltage at DC-link, and (c) phase-RMS voltages

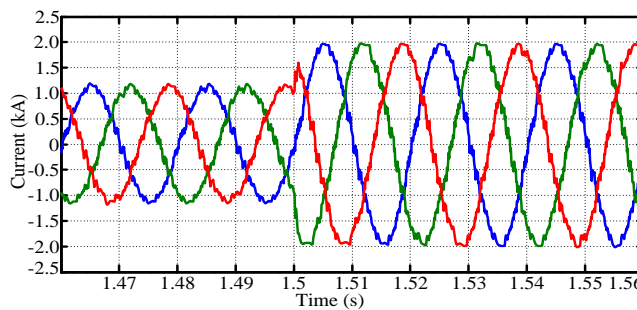

Figure 8. Instantaneous load bus currents

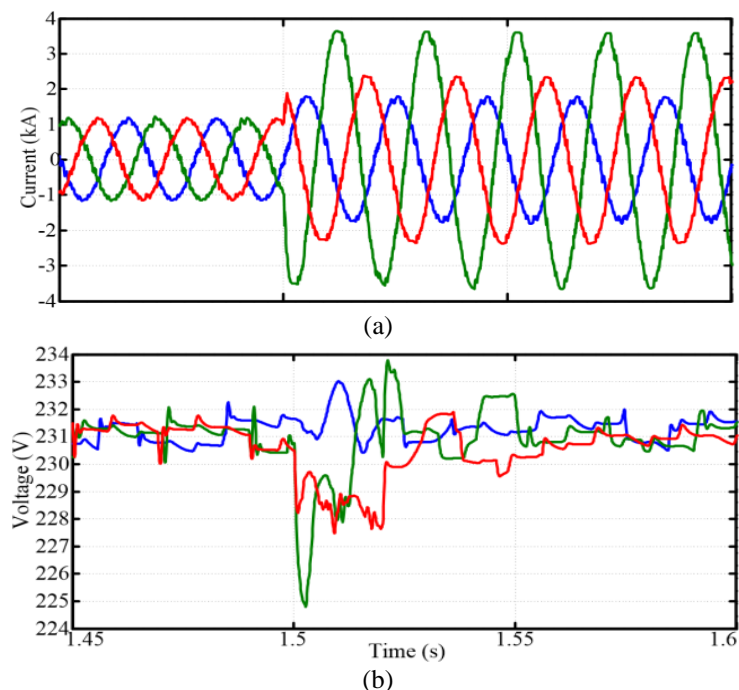

Figure 9. Performance under operation of unbalanced load: (a) current in unbalanced and (b) balanced RMS-phase voltages

5. CONCLUSION

LSTM based ANN controllers are designed for control methods of DC to DC converter and inverter in hybrid renewable energy sources powered standalone power supply system. The battery controller is designed to maintain power balanced between total generation and load. Novel inverter control scheme is developed to maintain constant voltage at AC bus during all possible conditions including variations in load, solar irradiance, and wind speed. Wind system, PV, and battery are integrated to supply reliable and stable at load bus. To achieve the realistic responses of the proposed control methods, hardware in the loop (HIL) is implemented with help of OPAL-RT modules. A balanced three phase voltages can maintain at load bus under the operation of unbalanced load by using proposed inverter control. The significant power quality is improved by proposed control schemes of inverter and DC to DC converter during all possible operating conditions.



REFERENCES

- [1] S. G. Malla *et al.*, "Coordinated power management and control of renewable energy sources based smart grid," *International Journal of Emerging Electric Power Systems*, vol. 23, no. 2, pp. 261–276, 2021, doi: 10.1515/ijeeps-2021-0113.
- [2] A. Dash, D. P. Bagarty, P. K. Hota, R. K. Behera, U. R. Muduli, and K. Al Hosani, "DC-Offset Compensation for Three-Phase Grid-Tied SPV-DSTATCOM Under Partial Shading Condition With Improved PR Controller," *Institute of Electrical and Electronics Engineers (IEEE)*, vol. 9, pp. 132215–132224, 2021, doi: 10.1109/access.2021.3115122.
- [3] H. U. R. Habib *et al.*, "Optimal Planning and EMS Design of PV Based Standalone Rural Microgrids," *Institute of Electrical and Electronics Engineers (IEEE)*, vol. 9, pp. 32908–32930, 2021, doi: 10.1109/access.2021.3060031.
- [4] C. Pradhan, M. K. Senapati, S. G. Malla, P. K. Nayak, and T. Gjengedal, "Coordinated Power Management and Control of Standalone PV-Hybrid System With Modified IWO-Based MPPT," *IEEE Systems Journal*, vol. 15, no. 3, pp. 3585–3596, 2021, doi: 10.1109/jsyst.2020.3020275.
- [5] D. Bhule, S. Jain, and S. Ghosh, "Control Strategy for Photovoltaic-Battery Based Standalone System," in *2020 IEEE First International Conference on Smart Technologies for Power, Energy and Control (STPEC)*, 2020, doi: 10.1109/stpec49749.2020.9297685.
- [6] S. G. Malla, C. N. Bhende, and S. Mishra, "Photovoltaic based water pumping system," in *2011 International Conference on Energy, Automation and Signal*, 2011, doi: 10.1109/iceas.2011.6147148.
- [7] S. G. Malla and C. N. Bhende, "Voltage control of stand-alone wind and solar energy system," *International Journal of Electrical Power & Energy Systems*, vol. 56, pp. 361–373, 2014, doi: 10.1016/j.ijepes.2013.11.030.
- [8] S. G. Malla and C. N. Bhende, "Enhanced operation of stand-alone 'Photovoltaic-Diesel Generator-Battery' system," *Electric Power Systems Research*, vol. 107, pp. 250–257, 2014, doi: 10.1016/j.epr.2013.10.009.
- [9] J. Cervantes, W. Yu, S. Salazar, and I. Chairez, "Takagi-Sugeno Dynamic Neuro-Fuzzy Controller of Uncertain Nonlinear Systems," *IEEE Transactions on Fuzzy Systems*, vol. 25, no. 6, pp. 1601–1615, 2017, doi: 10.1109/tfuzz.2016.2612697.
- [10] M. Landin, R. C. Rowe, and P. York, "Advantages of neurofuzzy logic against conventional experimental design and statistical analysis in studying and developing direct compression formulations," *European Journal of Pharmaceutical Sciences*, vol. 38, no. 4, pp. 325–331, 2009, doi: 10.1016/j.ejps.2009.08.004.



- [11] U. R. Muduli, K. Al Jaafari, K. Al Hosani, R. K. Behera, R. R. Khusnutdinov, and A. R. Safin, "Cell Balancing of Li-ion Battery Pack with Adaptive Generalised Extended State Observers for Electric Vehicle Applications," in *2021 IEEE Energy Conversion Congress and Exposition (ECCE)*, 2021. doi: 10.1109/ecce47101.2021.9595601.
- [12] P. Malla, S. G. Malla, and R. K. Calay, "Voltage control of standalone photovoltaic – electrolyzer- fuel cell-battery energy system," *International Journal of Emerging Electric Power Systems*, vol. 24, no. 5, pp. 649–658, 2022, doi: 10.1515/ijeeps-2022-0047.
- [13] R. D. Bhagiya and R. M. Patel, "PWM based Double loop PI Control of a Bidirectional DC-DC Converter in a Standalone PV/Battery DC Power System," in *2019 IEEE 16th India Council International Conference (INDICON)*, 2019. doi: 10.1109/indicon47234.2019.9028974.
- [14] Manisha, M. D. M. Masoom, and N. Kumar, "Comparative Study of Nonlinear Controllers for Standalone PV System," in *2021 Second International Conference on Electronics and Sustainable Communication Systems (ICESC)*, 2021. doi: 10.1109/icesc51422.2021.9532701.
- [15] U. R. Muduli and K. Ragavan, "Dynamic modeling and control of shunt active power filter," in *2014 Eighteenth National Power Systems Conference (NPSC)*, 2014. doi: 10.1109/npsc.2014.7103893.
- [16] A. Dash, D. P. Bagarty, P. K. Hota, U. R. Muduli, K. Al Hosani, and R. K. Behera, "Performance Evaluation of Three-Phase Grid-Tied SPV-DSTATCOM With DC-Offset Compensation Under Dynamic Load Condition," *Institute of Electrical and Electronics Engineers (IEEE)*, vol. 9, pp. 161395–161406, 2021, doi: 10.1109/access.2021.3132549.
- [17] V. Narayanan, S. Kewat, and B. Singh, "Solar PV-BES Based Microgrid System With Multifunctional VSC," *IEEE Transactions on Industry Applications*, vol. 56, no. 3, pp. 2957–2967, 2020, doi: 10.1109/tia.2020.2979151.
- [18] X. Song, Y. Zhao, J. Zhou, and Z. Weng, "Reliability Varying Characteristics of PV-ESS-Based Standalone Microgrid," *IEEE Access*, vol. 7, pp. 120872–120883, 2019, doi: 10.1109/access.2019.2937623.
- [19] K. Deepak, Y. Hazarathaiiah, U. Chaithanya, N. A. Charan, C. M. Awaise, and P. Sinjith, "Novel Control of Standalone Hybrid Wind-PV-Battery System for Improving Power Quality," in *2023 Second International Conference on Electronics and Renewable Systems (ICEARS)*, 2023. doi: 10.1109/icears56392.2023.10084981.
- [20] K. Deepak, M. Bhagya Lakshmi, A. D. Dheeraj, K. A. Kumar, C. Mohammed Ashraf, and G. Madhu Sudhan, "Novel Energy Management of Hybrid Wind-PV-Battery Supplied DC Microgrid," *2023 International Conference on Self Sustainable Artificial Intelligence Systems (ICSSAS)*. IEEE, 2023. doi: 10.1109/icssas57918.2023.10331662.
- [21] K. Deepak, R. K. Mandal, and V. Verma, "Super Twisting Sliding Mode Control of Small Scale Hybrid Renewable Energy Sources based Power Supply System," in *2023 International Conference on Computer, Electronics & Electrical Engineering & their Applications (IC2E3)*, 2023. doi: 10.1109/ic2e357697.2023.10262667.
- [22] K. Deepak, R. K. Mandal, and V. Verma, "Improving Power Quality in Hybrid PV - Wind Operated Standalone System with Dual Inverters by Using TSK Fuzzy Controllers," in *2023 International Conference on Computer, Electronics & Electrical Engineering & their Applications (IC2E3)*, 2023. doi: 10.1109/ic2e357697.2023.10262760.
- [23] K. Deepak, R. K. Mandal, and V. Verma, "Improvement of power quality by using novel controller for hybrid renewable energy sources based microgrid," *International Journal of Emerging Electric Power Systems*, vol. 0, no. 0, 2023, doi: 10.1515/ijeeps-2023-0020.
- [24] K. Deepak, R. K. Mandal, and V. Verma, "Novel aggregated controller of wind and PV based grid connected charging station for electric vehicle," *International Journal of Power Electronics and Drive Systems (IJPEDS)*, vol. 14, no. 4, p. 2319, 2023, doi: 10.11591/ijped.v14.i4.pp2319-2327.
- [25] K. Deepak, R. K. Mandal, and V. Verma, "Power Quality Improvement of a Hybrid Renewable Energy Sources Based Standalone System Using Neuro-Fuzzy Controllers," *Distributed Generation & Alternative Energy Journal*, 2023, doi: 10.13052/jwe1540-9589.2022.

BIOGRAPHIES OF AUTHORS



Yerragolla Hazarathaiiah    is currently research scholar of JNTU Ananthapuram and assistant professor of Electrical and Electronics Engineering of G. Pullaiah College of Engineering and Technology, Kurnool. He has about 12 years of experience in teaching. He has published several research papers in journals of both international and national repute. He holds M. Tech. degree from Sri Kottam Tulasi Reddy Memorial College of Engineering, JNTUH, Hyderabad in the field of electrical power systems. His research interests include the field of digital design, industrial applications, industrial electronics, industrial informatics, power electronics, motor drives, and renewable energy. He can be contacted at email: y lucky2008@gmail.com.



B. Venkata Rami Reddy    is currently professor of Electrical and Electronics Engineering of G. Pullaiah College of Engineering and Technology, Kurnool. He has about 18 years of experience in teaching and research. He has published several research papers in journals of both international and national repute. He holds B. Tech. and M. Tech. degree from JNTU, Hyderabad and Ph.D. from JNTUA, Ananthapuram. His research interests include the field of digital design, industrial applications, industrial electronics, industrial informatics, power electronics, motor drives, and renewable energy. He can be contacted at email: ramireddybv@gmail.com.