

# Optimizing resilience in large-scale integration of renewable energy sources: Exploring the role of STATCOM device

Chelladurai Chandarahasnan, Edwin Sheeba Percis

Department of Electrical and Electronics Engineering, Dr. M.G.R. Educational and Research Institute, Chennai, India

## Article Info

### Article history:

Received Oct 23, 2023

Revised Mar 12, 2024

Accepted Mar 28, 2024

### Keywords:

Grid optimization

Reactive power

Renewable energy sources

Solar

STATCOM

Transient stability

Wind

## ABSTRACT

Modern power grids in regions with high renewable energy sources face unique challenges. Incorporating renewable energy, like wind and solar, can cause voltage, frequency, and power fluctuations, leading to instability. This study focuses on Tamil Nadu's extra high voltage transmission system, which has significant wind generation. It explores the impact of large-scale renewable energy integration and proposes the use of static synchronous compensators (STATCOM), a part of flexible alternating current transmission systems (FACTS). STATCOM actively monitors and controls the grid, ensuring stability under unpredictable conditions. It is observed that the system maintains the grid stability with base rotor angle and voltage of 1.0 per unit during sudden loss 120 MW generator. Also, during the sudden loss of all renewable resources, the grid maintains the stability with rotor angle of 60 degree (base value). The findings provide insights into challenges and solutions, fortifying grid stability for accommodating more renewable energy without compromising reliability or efficiency.

This is an open access article under the [CC BY-SA](https://creativecommons.org/licenses/by-sa/4.0/) license.



## Corresponding Author:

Chelladurai Chandarahasnan

Department of Electrical and Electronics Engineering, Dr. M.G.R. Educational and Research Institute

Chennai, India

Email: chella.chandar@gmail.com

## 1. INTRODUCTION

The demand for electricity is rising worldwide, driven by the rapid growth of population and technological advancements, which contribute to environmental pollution conditions [1], [2]. In particular, power generation relying on fossil fuels contributes to the escalation of greenhouse gas emissions, leading to adverse effects on climatic conditions attributable to pollution particles [3], [4]. This underscores the growing importance of integrating renewable energy sources, particularly solar and wind, into the extra high voltage (EHV) grids. Tamil Nadu's EHV grid, managed by the Tamil Nadu Transmission Corporation Limited, plays a crucial role in this transition. However, the influx of renewables poses challenges to grid stability. This research investigates the impact of renewable energy on Tamil Nadu's EHV grid, aiming to identify current issues and potential solutions to facilitate smooth integration. Tamil Nadu stands out as a major energy producer in India, with an energy mix spanning from traditional thermal to renewable sources like wind and solar. By 2023, its installed capacity exceeds 38,000 MW [5], as show in Figure 1.

Tamil Nadu aims to significantly increase its reliance on green energy, targeting 50% of its grid to be powered by renewables by 2030, as per the 2023-2024 government budgets [6]. This ambition coincides with a surge in energy consumption, reaching around 18,000 MW. To meet this growing demand, Tamil Nadu plans to boost its installed power generation capacity by an impressive 33,000 MW by 2030, primarily through renewable sources. The plan involves harnessing the state's substantial renewable potential, including 20 GW from solar energy, 70 GW from onshore wind energy, and 30 GW from offshore wind energy.

Wind energy-a driving force: Tamil Nadu's landscape is a testament to its remarkable wind energy potential, especially in the Western Ghats. This region benefits from consistently high wind speeds, averaging between 6.5 to 7.5 meters per second at a 100 m hub height. Areas like Shencottah, Aralvaimozhi, Cumbum, and Palghat consistently experience strong winds, as shown in Figure 2 [7]. Tamil Nadu's installed wind power capacity is a significant contributor to India's total wind energy production. To achieve its ambitious goal of 70 GW from wind energy, the state plans to introduce a new policy focused on re-powering existing windmills to maximize the region's wind resources.

Exploring offshore wind-a game changer: beyond onshore wind potential, Tamil Nadu's extensive coastline presents substantial offshore wind energy prospects [8]. These untapped offshore wind resources represent a frontier of opportunity for realizing the green grid vision. Leveraging offshore wind can enhance energy generation and diversify the renewable energy mix, ensuring grid resilience. With its strong wind profile, Tamil Nadu has the potential to generate several gigawatts of offshore wind energy capacity. However, ensuring the reliability of the network is increasingly challenging, especially concerning the planning and operation aspects [9], [10].

Solar parks illuminating the future: Tamil Nadu's solar energy potential is equally compelling, thanks to its equatorial location. The state receives approximately 5-6 kWh/m<sup>2</sup>/day of solar insolation on average. This abundant solar resource can be harnessed through the installation of solar photovoltaic (PV) panels on various surfaces, including ground-mounted solar farms, rooftops, and industrial facilities. Regions like Kamuthi, Vellore, Sivaganga, Madurai, Ramnad, and Tirunelveli benefit from ample sunshine, making them ideal for large-scale solar installations [11]. Solar parks in these areas not only capture solar power but also support energy self-sufficiency and align with the state's clean energy goals.

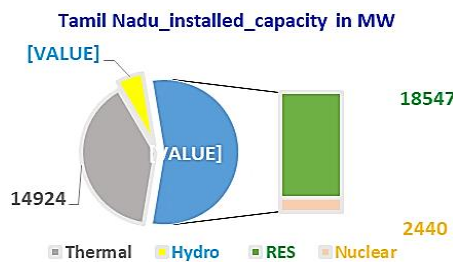

Figure 1. Tamil Nadu's generation installed capacity as of August 2023

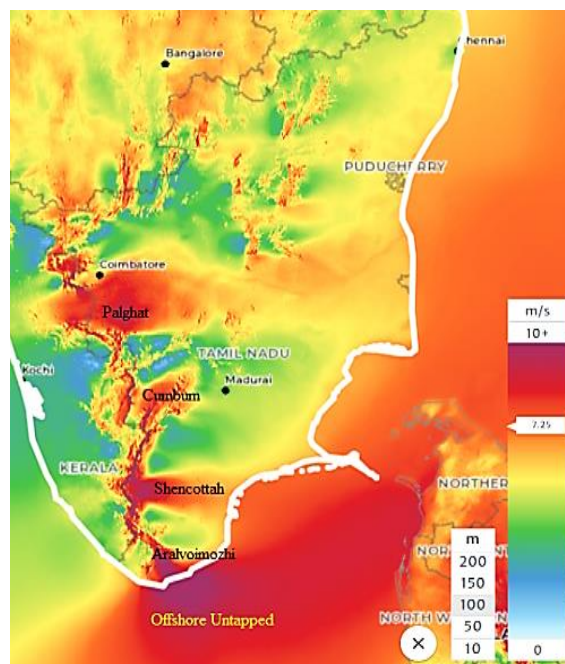

Figure 2. Key wind passes in Tamil Nadu (Global Wind Atlas – September 2023)

Integrating substantial renewable energy requires detailed planning, stability analysis, and contingencies assessment to ensure grid resilience and reliability. These analyses identify challenges and develop strategies for a smooth transition, minimizing disruptions. However, these challenges also bring opportunities, such as job creation, reduced water consumption, enhanced energy security, and alignment with climate goals. Strategic investments in renewable energy infrastructure, power evacuation, and grid balancing are essential. Tamil Nadu's commitment to a 50% green grid by 2030 reflects its dedication to climate mitigation and environmental stewardship. This endeavor extends beyond regional boundaries, serving as an example in the global fight against climate change by reducing emissions and fossil fuel reliance, aligning with international climate agreements, and inspiring other regions to follow suit.

Based on the introduction, the motivations of this work are listed: i) Recognizing issues in power grids with high renewable energy integration, including voltage, frequency, and power fluctuations that lead to instability; ii) Concentrating on the specific challenges and dynamics of Tamil Nadu's extra high voltage transmission system, which features significant wind generation; iii) Investigating the consequences of integrating large-scale renewable energy sources, with a particular emphasis on wind and solar, to understand their effects on grid stability; and iv) Proposing the implementation of static synchronous compensators (STATCOM), a FACTS technology, to actively monitor and control the grid and ensure stability under unpredictable renewable energy conditions. The remaining of the article is organized as: i) Robust literature survey attesting the scope of research and key findings is given in section 2; ii) Modelling of the test case is illustrated in section 3; iii) Results and discussions describing the core outcomes is illustrated in section 4; finally; and iv) Based on the attained outcomes, conclusions are given in section 5.

## 2. REVIEW OF EXISTING LITERATURE

In this section, the author presents a comprehensive overview of recent scholarly works as detailed in Table 1 (see in Appendix). These works examine Tamil Nadu's renewable energy potential and address global challenges associated with integrating substantial and fluctuating renewable energy into the power grid. This literature survey emphasizes STATCOM devices and FACTS in enhancing power system resilience during large-scale renewable energy integration. STATCOMs excel in reactive power compensation, voltage regulation, and grid stability, supporting modern power grid reliability. Inverter-based resources reduce reliance on traditional frequency control mechanisms, aligning with the dynamic nature of renewable energy sources (RES) integration. Advanced control strategies, hybrid systems, and strategic FACTS device placement strengthen grid stability. The research focuses on optimizing resilience in large-scale RES integration, with a specialized emphasis on STATCOM devices, chosen over other FACTS due to superior technical and economic factors.

## 3. METHODOLOGY

The research focuses on Tamil Nadu's 400 kV Kayathar pooling substation, a pivotal RES integration hub. Utilizing real-world wind data, the model was developed with "Power World" software. The substation includes 8×400 kV, 11×230 kV, and 3×110 kV feeders, along with two 315MVA Auto-transformers for the 230 kV network and one 200 MVA unit for the 110 kV side. The system incorporates an 820 MW wind generation capacity from seven wind farms and a 50 MW solar plant connected to the 230 kV and 110 kV buses, as show in Figure 3 (see in Appendix). Wind farm feeders employ the induction generator model, capturing real-world variability and responses. The 400 kV feeders serve as a key link to the wider power grid, facilitating the study of transient behaviors. The model includes the connection of 5×210 MW generators from the Tuticorin thermal power station to the 230 kV bus. System metrics, encompassing fault levels, system characteristics, synchronous generators, transformers, and feeder specifications, draw from field survey data, ensuring realism, and accuracy.

## 4. RESULTS AND DISCUSSIONS

In power system analysis, the PowerWorld Simulator is an essential tool. For this research, an electrical network model was meticulously developed using the simulator, with a base power of 100 MVA. This approach ensured that system metrics like voltages, currents, and power were consistently expressed in per unit (p.u.) values, simplifying analysis and maintaining component consistency. PowerWorld's user-friendly graphical interface and comprehensive features are valuable for various system studies, with strong capabilities in transient analysis to simulate rapid system changes under diverse disturbances. Within the PowerWorld Simulator, the SVSM03 block plays a crucial role in modeling and simulating STATCOM operation.

#### 4.1. Observation of load flow analysis

The base caseload flow closely reflects real-time power flow and considers 100% RES generation alongside 100% from 5×210 MW synchronous generators. Adhering to voltage limits as recommended by the Indian grid code, ensures the 400 kV, 230 kV, and 110 kV buses operate within permissible levels. Reactive power compensation is applied as needed. This load flow case, emphasizing maximum synchronous generator contribution and prevalent RES, aids in practical stability analysis of the network. Details of sources and load demand can be found in Tables 2 and 3. The total power generation in this selected scenario is 1917 MW, comprising 1050 MW from conventional sources, 817 MW from wind generation, and 50MW from the solar park. This collectively represents the full capacity of the installed RES.

In this scenario, the pooling station efficiently manages maximum RES generation, reducing the demand on synchronous generators and fulfilling 230 kV load requirements. This shift minimizes reliance on conventional generation, creating a greener, and more efficient power system while optimizing renewable sources. Load flow analysis yields crucial insights into the steady-state operation of the 400 kV pooling substation. The introduction of renewable sources with variable generation patterns induces voltage fluctuations, especially in highly renewable energy areas. Identifying these regions is vital for effective voltage support strategies and grid stability within defined limits.

Table 2. Details of sources accounted for the study case

Generation details Power grid	Rating (max)	MW accounted	% Gen	Line type	Line distance in KM
SynGen-5x210 MW	1050 MW	1050.0	100	Zebra	56.24
230kV VLUCY#	107 MW	107.0	50	Zebra	20.13
230kV WELSPAN#	50 MW	50.0	50	Zebra	5.56
230kV VLPNRI#	200 MW	200.0	50	Zebra	11.5
230kV SNGPN#1	150 MW	150.0	50	Zebra	26.3
230kV SNGPN#2	150 MW	150.0	50	Zebra	26.3
110kV KLVRNM#	40 MW	40.0	50	Panther	35
110kV AYNR#1	70 MW	70.0	50	Panther	2
110kV AYNR#2	100 MW	100.0	50	Panther	2
Total		1917.0			

Table 3. Details of load demand accounted for the subject study case

Load details	Line type	per kM impedance	Distance in KM	MW	MVA <sub>r</sub>
230kV ANUPM#	Zebra	0.08+0.4i	65	100	48
230kV MDU#	Zebra	0.08+0.4i	125	81	38
230kV TMPPT#	Zebra	0.08+0.4i	22	51	25
230kV KYTH#1	Zebra	0.08+0.4i	12	60	29
230kV KYTH#2	Zebra	0.08+0.4i	12	60	29
230kV TTN#	Zebra	0.08+0.4i	56.24	1200	506
Total				1552	675

#### 4.2. Assessment of transient stability-base case vs STATCOM

The study examines the stability of the 400 kV Kayathar pooling substation, assessing the impact of combining 5×210 MW synchronous generators with maximum renewable energy generation. It aims to gauge STATCOM's effectiveness in grid stabilization during contingencies. Various contingencies were assessed with a transient analysis simulation time of 15 seconds and a 2-second contingency simulation.

##### 4.2.1. Shutdown of 1×210 MW synchronous generator-1

To evaluate system stability, the deactivation of 1×210 MW synchronous generator-1 after 2 seconds was simulated. The impact on reference generator II and the roles of both STATCOM devices in managing this major contingency were analyzed. Figures 4 and 5 depict the results of this comparison, specifically focusing on rotor angle assessment for generator II.

In the base case, system disturbances were observed when a significant generator was shut down. However, integrating STATCOM greatly enhanced system stability. STATCOM, known for its quick response, provided robust support for voltage and reactive power, effectively damping system oscillations. To offset the loss of the key generator, the remaining generators and the exciter system increased their outputs, leading to noticeable fluctuations in both active and reactive power. Eventually, the system reached a new operational equilibrium.

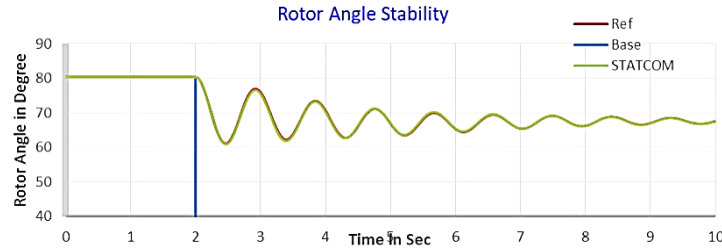

Figure 4. Plot of rotor angle stability of synchronous generators–1 & 2 for base case vs STATCOM

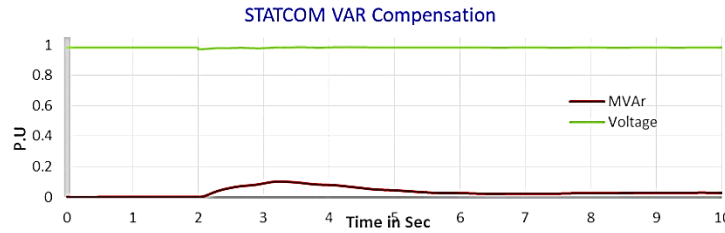

Figure 5. Plot of STATCOM dynamic VAR compensation

**4.2.2. Loss of all RES sources**

During the system's stability evaluation, an unexpected disconnection of all RES from the system occurred after 2 seconds. This event resulted in a decline in generation by approximately 867 MW including Solar Park. The efficiency of the STATCOM device in countering this significant disruption was investigated, with the findings showcased in Figures 6 and 7.

Disturbances in this scenario were more pronounced than in 4.2.1. The abrupt disconnection of all RES generators led to an immediate, sharp reduction in both active and reactive power. STATCOM quickly stepped in to compensate for the reactive power deficit, minimizing the dip in bus voltage and regulating the increasing voltage angle. Meanwhile, existing generators increased their outputs, resulting in noticeable fluctuations in both active and reactive power. With collective efforts from the remaining systems and the stabilizing role of STATCOM, the system eventually achieved a new stable operational equilibrium.

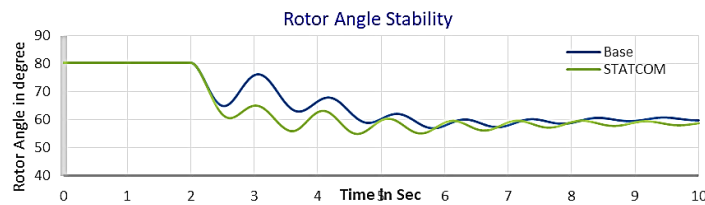

Figure 6. Plot of rotor angle synchronous generators–1 for base case vs STATCOM

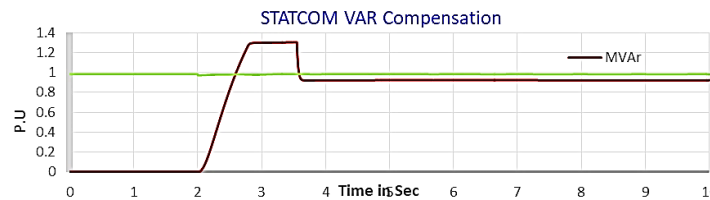

Figure 7. Plot of STATCOM dynamic VAR compensation

**4.2.3. Three-phase fault simulated in 230 kV Feeder#1**

The system's resilience was tested by simulating a 3-phase fault on the 230 kV Feeder #1 with a 100 MW load for 100ms, initiated two seconds into the simulation. The evaluation aimed to assess the system's responses and analyze how the STATCOM device reacted to this significant disturbance. Figures 8 and 9 provide the results of this extensive study.

The charts depict the system's response to a 3-phase fault on 230 kV Feeder #1. At the fault's onset, there is a notable voltage drop at the 230 kV reference bus, accompanied by significant changes in the rotor angle of the reference synchronous generator. These changes result in fluctuations in both active and reactive power, impacting the generator's speed. Without STATCOM, these fluctuations render the system unstable. However, with STATCOM in place, it promptly supplies the necessary reactive power, stabilizing the voltage. This rapid STATCOM action prevents substantial voltage drops and reduces fluctuations, and restoring system stability. After resolving the fault, the system returns to its pre-fault state, highlighting the effectiveness of the exciter system and STATCOM in maintaining stability during significant issues.

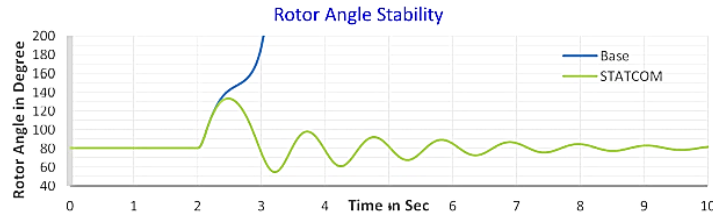

Figure 8. Plot of rotor angle stability of synchronous generators–1 for base case vs STATCOM

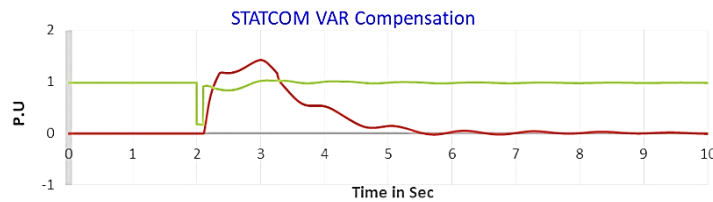

Figure 9. Plot of STATCOM dynamic VAR compensation

**4.2.4. Three-phase fault at remote end wind farm bus**

To assess the system's resilience, a simulation introduced a three-phase fault at the remote terminal of the wind farm bus, which was contributing a significant 200 MW to the grid. This perturbation was initiated 2 seconds into the simulation and persisted for a mere 100 ms. The core aim of this analysis was to elucidate the system's response in light of such disturbances. A comprehensive examination further spotlighted the contrasting performance dynamics of STATCOM during this significant disruption. Detailed observations from this exercise are captured in Figures 10 and 11.

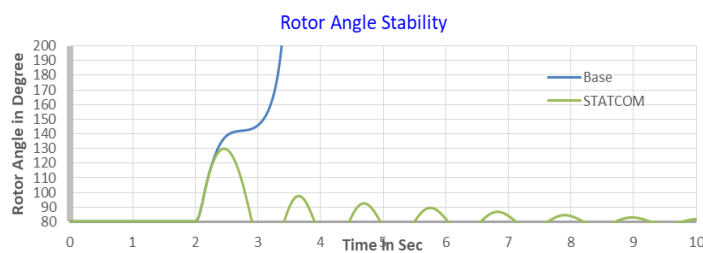

Figure 10. Plot of rotor angle stability of synchronous generators–1 for base case vs STATCOM

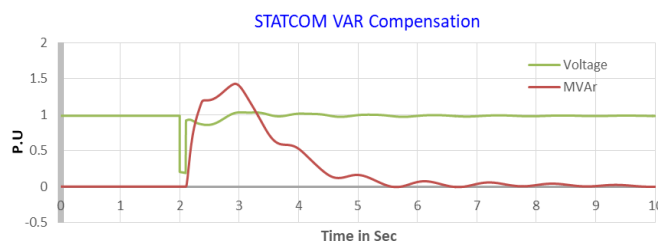

Figure 11. Plot of STATCOM dynamic VAR compensation

In this case, the plots elucidate the system's behavior in the presence of a three-phase fault at the remote terminal of the wind farm bus. Following the initiation of this disturbance, there's a significant reduction in voltage at the wind farm bus, accompanied by a pronounced deviation in the rotor angle of the primary generator. As a consequence, both active and reactive power levels exhibit notable fluctuations, influencing the operational speed of the generator. In the absence of STATCOM, the system demonstrates instability. However, with STATCOM integrated, it responds promptly, supplying the requisite reactive power to maintain voltage stability. Due to STATCOM's intervention, severe voltage reductions are mitigated and the system's stability is restored. Once the fault is rectified, system parameters revert to their baseline levels, underscoring the indispensable roles of both STATCOM and the exciter system in managing such disruptions. This comprehensive stability analysis enhances our understanding of system behavior during critical disturbances. STATCOM's introduction significantly improves the power system's resilience by rapidly injecting reactive power during contingencies, maintaining voltage levels within desired limits, dampening oscillations, and providing dynamic support during transient events. These capabilities ensure the system's return to stability after disruptions, underscoring STATCOM's effectiveness in strengthening grid stability and addressing identified vulnerabilities. The summarized results are in Table 4.

This work introduces several novel aspects in addressing the challenges posed by high renewable energy integration in modern power grids, with a particular focus on the extra high voltage transmission system in Tamil Nadu. By tailoring the investigation to this specific regional context, the research underscores the importance of developing region-specific strategies to effectively manage the complexities associated with renewable energy sources. A key contribution is the implementation of static synchronous compensators (STATCOM) as part of flexible alternating current transmission systems (FACTS). This dynamic technology actively monitors and controls the grid, offering a novel approach to ensuring stability under the unpredictable conditions associated with renewable energy. Furthermore, the study pioneers a comprehensive impact assessment, emphasizing the dynamics of large-scale integration of renewable sources, especially wind and solar. Resilience testing under diverse scenarios, including sudden losses of significant power generators or the entire renewable energy supply, provides a unique perspective on the system's robustness. Additionally, the research introduces a real-time monitoring and control approach to maintain grid stability, addressing uncertainties inherent in renewable energy sources. Overall, the study proposes a novel framework that strives to balance sustainability and reliability, fortifying grid stability while accommodating increased renewable energy without compromising efficiency or dependability.

Table 4. Base case vs STATCOM: transient stability observations

Case	Contingencies simulated		Transient stability observations	
			Base case	STATCOM
i	Shutdown of 1x210 synchronous generator-1	MW	Stable – System vulnerabilities surfaced during a major generator shutdown, causing fluctuations in both active and reactive power before stabilizing at a new operational equilibrium.	Enhanced stability - With STATCOM, rapid injection of reactive power significantly improved system damping and expeditiously restored stability.
ii	Interruption of all RES generators		Stable - Disconnecting all RES generators caused a sharp drop in both active and reactive power. The system eventually stabilized at a new equilibrium but with noticeable power fluctuations.	Swift reactive power compensation-STATCOM promptly compensated for the reactive power deficit, ensuring voltage stability and a quick return to a stable operational state.
iii	Three-phase fault simulated in Feeder #1	230kV	Unstable - The system's response to a 3-phase fault on 230kV Feeder #1 included voltage and rotor angle fluctuations, leading to instability.	Dynamic VAR support - STATCOM adjusted its output, preserving voltage levels, and aiding swift system recovery, mitigating the instability caused by the fault.
iv	Three-phase fault at remote end wind farm bus		Unstable - Following a three-phase fault at the remote terminal of the wind farm bus, the system experienced instability, marked by significant voltage reductions and power fluctuations.	Stabilizing impact - STATCOM, when integrated, efficiently restored system stability by rapidly supplying reactive power support, mitigating severe voltage reductions, and facilitating a swift return to stable system operation post-fault.

## 5. CONCLUSION

The simulations in various scenarios emphasize STATCOM's crucial role in enhancing power system stability. In each case, STATCOM significantly improved system resilience, whether by swiftly compensating for reactive power loss after a generator failure or providing dynamic voltage support during a fault. Notably, in highly disruptive events like three-phase faults, STATCOM transformed potentially unstable scenarios into stable ones. Its integration into power grids with substantial renewable energy is indispensable. Looking ahead, further research can explore advanced control strategies for devices like STATCOM in renewable-rich grids.

Analyzing STATCOM's synergy with other compensatory devices and assessing both technical and economic dimensions are essential for developing adaptable and efficient power grids to meet evolving energy demands.

## APPENDIX

Table 1. Overview of previous literature papers

Ref. no	Scope of research	Authors	Key findings
[12]	Grid stability with large-scale renewable energy integration	Chandarahasan and Percis	Integrating a FACTS device into Tamil Nadu's EHV network can enhance stability, facilitating greater renewable energy sources (RES) integration. This highlights the importance of effective monitoring, control and mitigation strategies to accommodate variable large-scale RES generation.
[13]	Pathways for Tamil Nadu's electric power sector: 2020-2030	Rose <i>et al.</i>	By 2030, substantial changes in Tamil Nadu's electricity supply are projected, driven by investments in wind, solar, and battery energy storage systems (BESS), while reducing coal, hydropower, and nuclear capacity. Emphasizing the necessity of policy, regulatory frameworks long-term planning to meet state and national renewable energy deployment goals.
[14]	Grid stability with large wind power integration	Sreedevi <i>et al.</i>	Extensive wind power integration impacts grid stability. The TANGEDCO system can accommodate up to 29.3% wind generation without stability issues. Highlighting the importance of grid codes and wind generator ride-through capabilities to sustain grid stability.
[15]	Stability analysis of green energy corridors	Percis <i>et al.</i>	Focusing on optimizing thermal generation, unit commitment decisions, and economical dispatch in the presence of RES. Emphasizing the need for an optimized network with spinning reserves and storage to manage RES variability.
[16]	Greening the grid: integrating 175 GW of renewable energy	Palchak <i>et al.</i>	Discusses the feasibility of integrating 100 GW solar and 60 GW wind into India's power grid. Highlights that with planned transmission and generation capacity expansion, minimal renewable energy (RE) curtailment can be achieved. Stressing the importance of regulations, operational rules, and market mechanisms in unlocking power system flexibility for RE integration.
[17]	FACTS devices for reactive power compensation and power flow control	Chorghade <i>et al.</i>	Modern FACTS devices offer advantages in controlling both active and reactive power flow in transmission lines, primarily focusing on reactive power compensation.
[18]	Inertia and the power grid: a guide without the spin	Denholm <i>et al.</i>	Inverter-based resources can replace synchronous generators in power grids, offering faster response times and reducing the need for traditional inertia-based frequency control.
[19]	Dynamic stability analysis by a selection of the optimal location of STATCOM	Dhal	Optimal STATCOM location and tuning via particle swarm optimization significantly enhance dynamic stability in power systems.
[20]	Evaluation of technical solutions to improve transient stability in power systems with wind power generation	Marco Tina <i>et al.</i>	Wind power can decrease system stability, but additional wind turbines and fast-acting exciters can improve rotor angle and frequency stability. SVC and STATCOM devices are effective for frequency control.
[21]	Transient stability of power systems integrated with inverter-based generation	He <i>et al.</i>	Inverter-based generation impacts power system stability by constraining power angles, affecting transient stability margin, and critical clearing time (CCT).
[22]	Hybrid control of a multi-area multi-machine power system with FACTS devices	Therattil <i>et al.</i>	The proposed hybrid unified power flow controller (UPFC) controller effectively dampens inter-area oscillations in multi-machine power systems.
[23]	Modified WOA-based battery-STATCOM	Singh and Saini	A novel controller is introduced to optimally fine-tune the parameters of the battery-STATCOM. The optimal tuning of the Battery-STATCOM controller is achieved through the utilization of a rule-based modified WOA.
[24]	Reactive power compensation for wind farms based on STATCOM	Lan and Du	To counter potential voltage instability from system disturbances, a STATCOM device is crucial for supplying reactive power, ensuring enhanced stability in the wind power system, as evidenced by simulation results in this study.
[25]	Modelling, control, stability, optimal location, integration, application, and installation	Sharma <i>et al.</i>	The paper comprehensively explores diverse aspects of STATCOM, encompassing models, test systems, and findings from various research endeavors. It delves into the modeling, control technology, stability, optimal placement, applications, and installation of STATCOM.



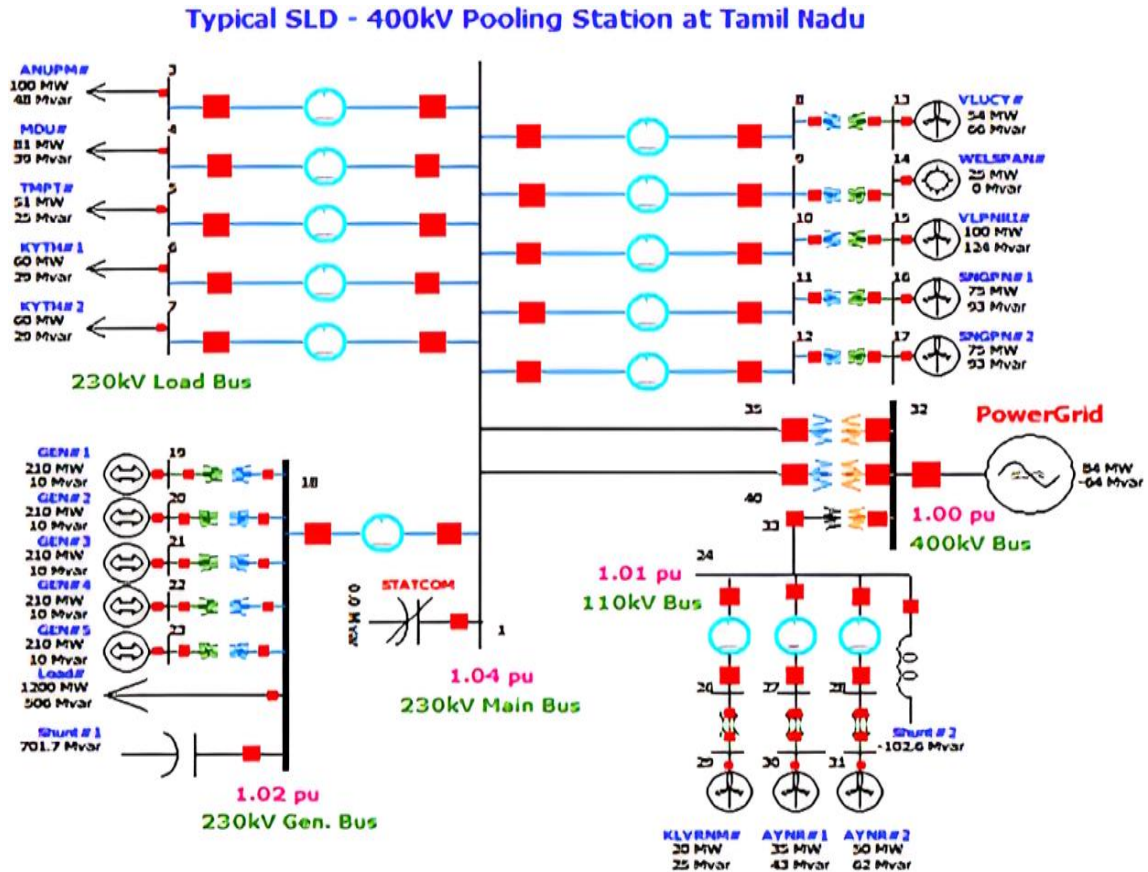

Figure 3. Typical SLD-400kV RES pooling substation



## REFERENCES

- [1] C. Venkatesan, R. Kannadasan, M. H. Alsharif, M.-K. Kim, and J. Nebhen, "Assessment and integration of renewable energy resources installations with reactive power compensator in indian utility power system network," *Electronics*, vol. 10, no. 8, p. 912, Apr. 2021, doi: 10.3390/electronics10080912.
- [2] M. Rajalakshmi, S. Chandramohan, R. Kannadasan, M. H. Alsharif, M.-K. Kim, and J. Nebhen, "Design and validation of BAT algorithm-based photovoltaic system using simplified high gain quasi boost inverter," *Energies*, vol. 14, no. 4, p. 1086, Feb. 2021, doi: 10.3390/en14041086.
- [3] V. S. S. Balaguru, N. J. Swaroopan, K. Raju, M. H. Alsharif, and M.-K. Kim, "Techno-economic investigation of wind energy potential in selected sites with uncertainty factors," *Sustainability*, vol. 13, no. 4, p. 2182, Feb. 2021, doi: 10.3390/su13042182.
- [4] P. Pandiyan, S. Saravanan, K. Usha, R. Kannadasan, M. H. Alsharif, and M.-K. Kim, "Technological advancements toward smart energy management in smart cities," *Energy Reports*, vol. 10, pp. 648–677, Nov. 2023, doi: 10.1016/j.egy.2023.07.021.
- [5] Npp.gov.in, "Public reports capacity2 Southern 2023-08," 2023. <https://npp.gov.in/public-reports/cea/monthly/installcap/2023/AUG/capacity2-Southern-2023-08.pdf>
- [6] V. Senthilbalaji, "Policy note 2023 - 2024," *Minister for Electricity, Prohibition and Excise*, 2023. [https://cms.tn.gov.in/sites/default/files/documents/energy\\_e\\_pn\\_2023\\_24.pdf](https://cms.tn.gov.in/sites/default/files/documents/energy_e_pn_2023_24.pdf)
- [7] Energydata.info, "Global wind atlas," *globalwindatlas.info*, 2024. <https://globalwindatlas.info/en/area/India>
- [8] Fowind, "Feasibility study for offshore wind farm development in Tamil Nadu," India, 2018. [Online]. Available: <https://gwec.net/wp-content/uploads/2018/03/FEASIBILITY-STUDY-FOR-OFFSHORE-WIND-FARM-DEVELOPMENT-IN-TAMIL-NADU.pdf>
- [9] S. Ganesan, U. Subramaniam, A. A. Ghodke, R. M. Elavarasan, K. Raju, and M. S. Bhaskar, "Investigation on sizing of voltage source for a battery energy storage system in microgrid with renewable energy sources," *IEEE Access*, vol. 8, pp. 188861–188874, 2020, doi: 10.1109/ACCESS.2020.3030729.
- [10] D. Kucevic *et al.*, "Standard battery energy storage system profiles: Analysis of various applications for stationary energy storage systems using a holistic simulation framework," *Journal of Energy Storage*, vol. 28, p. 101077, Apr. 2020, doi: 10.1016/j.est.2019.101077.
- [11] Energydata.info, "Global solar atlas," *globalsolaratlas.info*, 2024. <https://globalsolaratlas.info/map?c=21.943046,82.661133,5&r=IND>
- [12] C. Chandarahasnan and E. Sheeba Percis, "The accessible large-scale renewable energy potential and its projected influence on Tamil Nadu's grid stability," *Indonesian Journal of Electrical Engineering and Computer Science*, vol. 31, no. 2, pp. 609–616, Aug. 2023, doi: 10.11591/ijeecs.v31.i2.pp609-616.
- [13] A. Rose, I. Chernyakhovskiy, D. Palchak, M. Schwarz, S. Koebrich, and M. Joshi, "Pathways for Tamil Nadu's electric power sector: 2020 - 2030," Golden, CO (United States), Jan. 2021. doi: 10.2172/1760656.



- [14] J. Sreedevi, M. K.S, N. C. P., S. Ravichandran, R. Santhanakumar, and T. Sumathi, "Grid stability with large wind power integration - a case study," in *2016 IEEE Region 10 Conference (TENCON)*, Nov. 2016, pp. 571–575. doi: 10.1109/TENCON.2016.7848065.
- [15] E. Sheeba Percis *et al.*, "Stability analysis of dedicated green energy corridors and enhancement of renewable energy evacuation," *IOP Conference Series: Materials Science and Engineering*, vol. 993, no. 1, p. 012071, Dec. 2020, doi: 10.1088/1757-899X/993/1/012071.
- [16] D. Palchak *et al.*, "Greening the grid: pathways to integrate 175 gigawatts of renewable energy into India's electric grid, Vol. I -- national study," Golden, CO (United States), Jun. 2017. doi: 10.2172/1369138.
- [17] A. Chorghade and V. A. Kulkarni Deodhar, "FACTS devices for reactive power compensation and power flow control – recent trends," in *2020 International Conference on Industry 4.0 Technology (I4Tech)*, Feb. 2020, pp. 217–221. doi: 10.1109/I4Tech48345.2020.9102640.
- [18] P. Denholm, T. Mai, R. Kenyon, B. Kroposki, and M. O'Malley, "Inertia and the power grid: a guide without the spin," Golden, CO (United States), May 2020. doi: 10.2172/1659820.
- [19] P. K. Dhal, "Dynamic stability analysis by selection of optimal location of STATCOM through power system stabilizer tuned by particle swarm optimization technique," in *2017 International Conference on Energy, Communication, Data Analytics and Soft Computing (ICECDS)*, Aug. 2017, pp. 3074–3079. doi: 10.1109/ICECDS.2017.8390021.
- [20] G. M. Tina, G. Maione, and S. Licciardello, "Evaluation of technical solutions to improve transient stability in power systems with wind power generation," *Energies*, vol. 15, no. 19, p. 7055, Sep. 2022, doi: 10.3390/en15197055.
- [21] X. He and H. Geng, "Transient stability of power systems integrated with inverter-based generation," *IEEE Transactions on Power Systems*, vol. 36, no. 1, pp. 553–556, Jan. 2021, doi: 10.1109/TPWRS.2020.3033468.
- [22] J. P. Therattil *et al.*, "Hybrid control of a multi-area multi-machine power system with FACTS devices using non-linear modelling," *IET Generation, Transmission & Distribution*, vol. 14, no. 10, pp. 1993–2003, May 2020, doi: 10.1049/iet-gtd.2019.1165.
- [23] S. Singh and S. Saini, "Alleviation and control of chaotic oscillations in SMIB power systems using a modified-Whale optimization-based battery-STATCOM," *Journal of Engineering Research*, Oct. 2023, doi: 10.1016/j.jer.2023.10.004.
- [24] Y. Lan and S. Du, "Improvement of grid-connected reactive power compensation for wind farms based on STATCOM," *Journal of Physics: Conference Series*, vol. 2427, no. 1, p. 012004, Feb. 2023, doi: 10.1088/1742-6596/2427/1/012004.
- [25] S. Sharma *et al.*, "A comprehensive review on STATCOM: paradigm of modeling, control, stability, optimal location, integration, application, and installation," *IEEE Access*, vol. 12, pp. 2701–2729, 2024, doi: 10.1109/ACCESS.2023.3345216.

## BIOGRAPHIES OF AUTHORS



**Chelladurai Chandarhasan**    is currently pursuing his Ph.D. from Dr. M.G.R. Education and Research Institute. He obtained his B.E. from Anna University, Guindy, and M.Tech. from Dr. M.G.R. Educational and Research Institute, Chennai. His specialization in PG is Electrical Power Systems. His research interests include renewable energy sources, power system stability analysis, wide area monitoring and control systems (WAMS), and power system communication. He is presently working as an assistant executive engineer at TANGEDCO Ltd (Subsidiary of TNEB Ltd), Chennai, Tamil Nadu, India. He can be contacted at email: chella.chandar@gmail.com.



**Edwin Sheeba Percis**    obtained her B.E. from Madras University and M.E. from Anna University. She received her Ph.D. degree from Dr. M.G.R. Educational and Research Institute. Her specialization in PG is Power Electronics and Drives. Her research interests include renewable energy technology, power system simulation studies, power electronics, transmission and distribution. She is presently working as a professor of the Electrical and Electronics Engineering Department at Dr. M.G.R. Educational and Research Institute, Chennai, Tamil Nadu, India. She has a strong association with the Ministry of Rural Development, Government of India, for the implementation of the DDU-GKY scheme in the state of Tamilnadu through an 8.83 crore funded project as project head and authorized signatory. She can be contacted at email: sheebapercis.eee@dmgrdu.ac.in.