

# Modeling and Simulation of Fuel Cell (Choi Model) Based 3-Phase Voltage Source Inverter

**Gaurav Sachdeva**

JSS Inst of Engg. & Tech,  
Patiala, Punjab, India. +91-987-222-4444  
e-mail: ergauravsachdeva@gmail.com

## Abstract

*In the present work, performance of three phase voltage source inverter, while feeding different power factor loads, has been investigated. Fuel cells models namely Choi model are used in input side as a DC source while dynamic load have been used at the output side. Dynamic load used is induction motor (IM). Performance of IM has been investigated under various loading conditions. ANN based control strategy has been proposed to find the conduction angle of a Three Phase VSI and verified for IM load. Simulations have been performed using PSIM 7.0.5 and MATLAB 7.0.4.*

**Keywords:** ANN, Choi model, fuel cell, induction motor, voltage source inverter

## 1. Introduction

Fuel cells are mostly analyzed electrochemically, this analysis mathematical models which are important not only for improving the design of membranes flow fields, and catalysts but also for determining the optimal operating condition like fuel flow rates, humidity and temperature. Choi model is derived from the frequency response of the fuel cell.

Research on [1] focuses on a vehicular system powered by a fuel cell and equipped with two secondary energy storage devices: battery and ultra-capacitor (UC). A wavelet and fuzzy logic (FL) based energy management strategy is proposed for the developed hybrid vehicular system. In [2] shows the control of the fuel cell for stand-alone and grid connection. A power conditioning unit is designed for the solid oxide fuel cell, which can be used for other fuel cells with converter and the inverter of different ratings, but the control strategy using fuzzy logic (FL) will remain the same for designing the controllers. In [3] presents a fuel cell hybrid bus which is equipped with a fuel cell system and two energy storage devices, i.e., a battery and an ultra capacitor (UC).

An energy management strategy based on fuzzy logic, which is employed to control the power flow of the vehicular power train, is described. This strategy is capable of determining the desired output power of the fuel cell system, battery and ultra capacitor according to the propulsion power and recuperated braking power. A control strategy is presented by [4] which is suitable for miniature hydrogen/air proton-exchange membrane (PEM) fuel cells. The control approach is based on process modeling using fuzzy logic. The parameters of the fuzzy rule base are determined by plotting characteristic diagrams of the fuel cell stack at constant temperatures. FC system and UC bank supply power demand using a current-fed full bridge dc-dc converter and a bidirectional dc-dc converter is presented by [5]. It focuses on a novel fuzzy logic control algorithm integrated into the power conditioning unit (PCU for the hybrid system).

The control strategy is capable of determining the desired FC power and keeps the dc voltage around its nominal value by supplying propulsion power and recuperating braking energy. In [6], a fuzzy logic algorithm has been used to determine the fuel cell output power depending on the external power requirement and the battery state of charge (SoC). If-then operation rules are implemented by fuzzy logic for the energy management of the hybrid system. In [7] presents an enhanced control of the power flows on a FCHV in order to reduce the hydrogen consumption, by generating and storing the electrical energy only at the most suitable moments on a given driving cycle. The proposed strategy which can be implemented on-line is based on a fuzzy logic decision system. A FC/UC hybrid vehicular power system using a wavelet based load sharing and fuzzy logic based control algorithm is proposed by [8]. While wavelet transforms are suitable for analyzing and evaluating the dynamic load demand profile of a hybrid electric vehicle (HEV), the use of fuzzy logic controller is appropriate for the hybrid system control.

The performance of a direct methanol fuel cell (DMFC) was modeled by [9] using adaptive-network-based fuzzy inference systems (ANFIS). The artificial neural network (ANN) and polynomial-based models were selected to be compared with the ANFIS in respect of quality and accuracy. Based on the ANFIS model obtained, the characteristics of the DMFC were studied. The results show that temperature and methanol concentration greatly affect the performance of the DMFC. Within a restricted current range, the methanol concentration does not greatly affect the stack voltage. In order to obtain higher fuel utilization efficiency, the methanol concentrations and temperatures should be adjusted according to the load on the system. Continuous-time recurrent fuzzy systems are employed by [10] to model the electrical behavior of a solid oxide fuel cell, which both can be described qualitatively and is known quantitatively from measurements. Due to the transparency of the model an easy

estimation of its parameters is possible. Additionally, the model parameters are optimized numerically to enhance the model performance.

Thermal management for a solid oxide fuel cell (SOFC) is actually temperature control, due to the importance of cell temperature for the performance of an SOFC. A modified Takagi-Sugeno (T-S) fuzzy model that is suitable for nonlinear systems is built to model the SOFC stack. The model parameters are initialized by the fuzzy c-means clustering method, and learned using an off-line back-propagation algorithm [11] In order to obtain the training data to identify the modified T-S model; a SOFC physical model via MATLAB is established. The temperature model is the centre of the physical model and is developed by enthalpy-balance equations. It is shown that the modified T-S fuzzy model is sufficiently accurate to follow the temperature response of the stack, and can be conveniently utilized to design temperature control strategies. [12] Discusses how genetic algorithm were applied to optimize a proton exchange membrane fuel cell stack design by searching for the best configuration in terms of number of cells and cell surface area. In [13] describes the use of multi objective genetic algorithms in the design of a fuzzy logic control system for a solid oxide fuel cell.

**2. Simulation Results of Dynamic Load**

In this paper the dynamic load used is induction motor. The parameters of induction motor used are presented in Table 1. Simulation results of 3-Φ voltage source inverter (VSI) fed using Choi model of fuel cells for induction motor are presented, Simulation are performed on induction motor to find load line to line Voltage ( $V_{LL}$ ), starting current ( $I_{st}$ ), steady state current ( $I_{steady}$ ) which is maximum value, %Current T.H.D ( $I_{T.H.D}$ ), maximum Torque ( $T_{max}$ ), Speed corresponding o maximum Torque ( $N_{Tmax}$ ), Efficiency corresponding to maximum Torque ( $\eta_{Tmax}$ ), Operating Speed ( $N_{oper}$ ), induction motor operating Torque ( $T_{LM}$ ), Load Torque ( $T_{load}$ ) Operating Efficiency ( $\eta_{oper}$ ) at various loaded conditions, which are No load, Constant Torque load ( $T_c$ ),  $T_{load} = k_1\omega$  load,  $T_{load} = k_2\omega^2$  load =  $T_{load} = k_3\omega^3$  load. Where  $k_1, k_2, k_3$  are load constants.

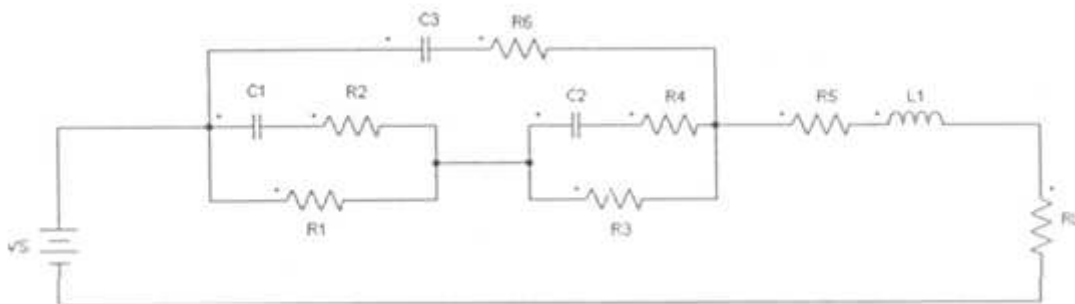

Fig. 1 Choi dynamic model of equivalent electrical circuit of fuel cell

**2.1 Simulation Results of Induction motor being Fed from 3-Φ VSI Using Choi Model of Fuel cell.**

Simulation are performed on induction motor being fed from 3-Φ VSI using Choi model of fuel cell using following load constants:  $T_c = 30$  N-m,  $K_1 = 0.672726$ ,  $K_2 = 7.890585 \cdot 10^{-3}$  and  $K_3 = 9.255642 \cdot 10^{-5}$ .

Table 1 Performance parameters for various loads of induction motor being fed from 3-Φ VSI using Choi model of fuel cell.

Parameter	Noload	$T_c$	$T_{load}=k_1\omega$	$T_{load}=k_2\omega^2$	$T_{load}=k_3\omega^3$
$V_{LL}$	399.531	248.827	246.763	257.157	259.732
$I_{st}$	64.9712	64.9726	64.9712	64.9712	64.9712
$I_{steady}$	18.093	18.6176	33.3313	31.0995	30.7934
$I_{T.H.D.}$	30.28028	6.090577	7.831105	9.53096	9.883031
$T_{max}$	57.3475	58.7588	59.2784	56.0828	56.143
$N_{Tmax}$	814.043	821.512	778.457	803.032	807.024
$\eta_{Tmax}$	-	82.1512	77.8457	80.3032	80.7024
$T_{LM}$	-	31.8273	52.119	54.5808	52.2069
$T_{load}$	-	30	51.3322	54.5808	52.2069
$N_{oper}$	-	965.03	728.657	790.581	783.567
$\eta_{oper}$	-	96.503	72.8657	79.0581	78.3567

Table 1 shows Performance parameters for various loads of induction motor being fed from 3-Φ VSI using Choi model of fuel cell. Table 1 indicates the following:

- The starting current ( $I_{st}$ ) remains almost same irrespective various loading conditions.

- The %Current T.H.D ( $I_{T.H.D}$ ) is maximum in case of No load condition.
- The maximum Torque ( $T_{max}$ ) remains irrespective of various loading conditions.
- The steady state current ( $I_{steady}$ ) is dependent on type load.
- The slip corresponding to maximum torque is maximum under linearly loaded condition.
- The Efficiency corresponding to maximum Torque ( $\eta_{Tmax}$ ) is almost constant irrespective of various loading conditions is around 80%.
- The operating Efficiency ( $\eta_{oper}$ ) is relatively more for constant Torque load.

## 2.2 Simulation Results of Induction motor being Fed from 3- VSI Using Choi model of Fuel cell when Conduction angle Changes from $140^0$ to $150^0$ with Constant Torque Load.

Simulation have been performed on induction motor being fed from 3- $\Phi$  VSI using Dicks-Larminie model of fuel cell when conducting angle changes from  $140^0$  to  $150^0$  with Constant Torque load to find variation of % Current T.H.D. Table 2 shows variation of % current T.H.D with Conduction Angle for 3- $\Phi$  VSI fed using model of fuel cell feeding induction motor with constant Torque load. Table 8.16 indicates that as the conduction angle increases the %Current T.H.D decreases for 3- $\Phi$  VSI fed using Choi model of fuel cell feeding induction motor with constant Torque load.

Table 2 Variation of % Current T.H.D with conduction angle for 3- $\Phi$  VSI fed using Choi model of fuel cell feeding induction motor with constant Torque load.

Conduction angle in degrees	% Current T.H.D
140	6.099633
141	6.055969
142	6.025061
143	5.99453
144	5.968901
145	5.943496
146	5.922419
147	5.902639
148	5.886761
149	5.874805
150	5.860894

## 2.3 ANN Based Control Strategy for Induction motor

In the thesis, a control strategy for induction motor being fed from 3- $\Phi$  VSI using Choi model of fuel cell which feeds Constant Torque load ( $T_c$ ) is proposed which uses multilayer back propagation feed forward neural network. This control strategy gives good estimate of conduction angle. The neural network takes % Current T.H.D (X) as input and gives Conduction Angle (CA) corresponding to that % Current T.H.D (X). The network is set with 'logsig' activation function at the middle layer and purelin activation function at the output layer. The design of the network and selection of optimum training parameters are performed by trial and error. Furthermore, tansig function is used which causes fewer epochs as compared to other training functions. Therefore, when an input is applied in the network, it will begin training based on the given data in order to produce the approximate results. The results obtained from Neural Network are verified with the results that are obtained from Excel Curve fitting. Fig 2 shows block diagram of ANN based control strategy for induction motor. Fig 8.2 indicates that the control strategy takes % Current T.H.D (X) as input and gives Conduction Angle (CA) as output.

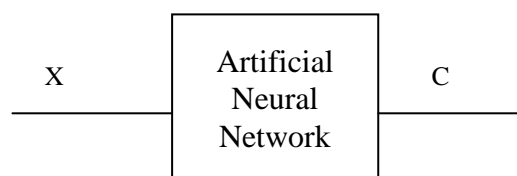

Fig. 2 Block diagram of ANN based control strategy for induction motor

Table 3 Result and verification of control strategy of induction motor

X	CA from neural network	CA from Excel Curve fitting
6.07	140.625	140.614
6.03	141.645	141.6453
6.015	142.1224	142.1189
5.97	143.8283	143.8245
5.95	144.7141	144.7195
5.935	145.4394	145.6988
5.92	146.227	146.2201
5.89	147.9076	147.9104
5.88	148.5071	148.516
5.872	149.0237	149.0157

## 2.4 Results and verification of ANN based control strategy for induction motor.

Table 3 shows results and verification of control strategy for induction motor fed from 3- $\Phi$  VSI using Choi model of fuel cell while feeding constant Torque load ( $T_c$ ). Table 3 indicates that ANN based control strategy is giving satisfactory results for induction motor.

## 3. Conclusion

In the present work, performance of inverter while feeding different power factor loads has been investigated. Fuel cells are used in the input side as a source while in the output side dynamic load is considered. The following conclusions are drawn for Induction motor load i.e. dynamic load.

1. The Starting current ( $I_{st}$ ) remains almost irrespective of various loading conditions.
2. The % Current T.H.D ( $I_{T.H.D}$ ) is maximum in case of No load condition.
3. The maximum Torque ( $T_{max}$ ) remains irrespective of various loading conditions.
4. The steady state current ( $I_{steady}$ ) is dependent on type load.
5. The slip corresponding to maximum torque is maximum under linearly loaded condition.
6. The Efficiency corresponding to maximum Torque ( $\eta_{Tmax}$ ) is almost constant irrespective of various loading conditions.
7. The operating Efficiency ( $\eta_{oper}$ ) is relatively more for constant Torque load.
8. ANN gives very fast and accurate results and it can be used for online calculations.

## References

- [1] O.Erding, B. Vural, M.Uzunoglu, "A wavelet logic based energy management strategy for a fuel cell/battery/ultra-capacitor hybrid vehicular power system", *Journal of Power Sources*, Volume 194, Issue 1, 20 October 2009, Pages 369-380.
- [2] A.Sakhare, A.Davari, A.Feliachi, "Fuzzy logic control of fuel cell for stand-alone and grid connection", *Journal of Power Sources*, Volume 135, Issues 1-2, 3 September 2004, Pages 165-176.
- [3] D.Gao, Z.Jin, Q.Lu, "Energy management strategy based on fuzzy logic for a fuel cell hybrid bus", *Journal of Power Sources*, Volume 185, Issue 1, 15 October 2008, Pages 311-317.
- [4] J.O. Schumacher, P. Gemmar, M. Denne, M. Zedda, M. Stueber, "Control of miniature proton exchange membrane fuel cells based on fuzzy logic", *Journal of Power Sources*, Volume 129, Issue 2, 22 April, Pages 143-151.
- [5] M.C. Kisacikoglu, M. Uzunoglu, M.S. Alam, "Load sharing using fuzzy logic control in a fuel cell/ultra capacitor hybrid vehicle", *International Journal of Hydrogen Energy*, Volume 34, Issue 3, February 2009, Pages 1497-1507.
- [6] K.S.Jeong, W.Y.Lee, C.S.Kim, "Energy management strategies of a fuel cell/battery hybrid system using fuzzy logics", *Journal of Power Sources*, Volume 145, Issue 2, 18 August 2005, Pages 319-326.
- [7] S. Caux, W. Hankache, M. Fadel, D. Hissel, "On-line fuzzy energy management for hybrid fuel cell systems", *International Journal of Hydrogen Energy*, In Press, Corrected Proof, Available online 13 January 2010.
- [8] O. erdinc, B. Vural, M. uzunoglu, Y. Ates, "Modeling and analysis of an FC/UC hybrid vehicular power system using a wavelet-fuzzy logic based load sharing and control algorithm", *International Journal of Hydrogen Energy*, Volume 34, Issue 12, June 2009, Pages 5223-5233.
- [9] R. Wang, L. Qi, X.Xie, Q. ding, C. Li, C.C.M. Ma, "Modeling of a 5-cell direct methanol fuel cell using adaptive-network-based fuzzy inference systems", *Journal of Power Sources*, Volume 185, Issue 2, 1 December 2008, Pages 1201-1208.
- [10] A.Flemming, J.Adamy, "Modeling solid oxide fuel cells using continuous-time recurrent fuzzy systems", *Engineering Applications of Artificial Intelligence*, Volume 21, Issue 8, December 2008, Pages 1289-1300.
- [11] J.Yang, X.Li, H.G. Mou, L. Jian, "Control-oriented thermal management of solid oxide fuel cells based on a modified Takagi-Sugeno fuzzy model", *Journal of Power Sources*, Volume 188, Issues 2, 15 March 2009, Pages 475-482.
- [12] I.Mohamed, N.Jenkins, "Proton exchange membrane (PEM) fuel cell stack configuration using genetic algorithm", *Journal of Power Sources*, Volume 131, Issues 1-2, 14 May 2004, Pages 142-146.
- [13] F. Jurado, M.Valverde, "Enhancing the electrical performance of a solid oxide fuel cell using multi objective genetic algorithm", *Renewable Energy*, Volume 30, Issue 6, May 2005, Pages 881-902.

## Bibliography of author



Prof Sachdeva has done B.Tech (Electrical Engg), M.Tech (Power Engg.). He is currently pursuing Ph.D in Electrical Engg. He has more than 8 years of Research & Teaching experience. He has authored 3 international and 2 national books. He has published various papers in national & international conference & journals.