

A New FOC Approach of Induction Motor Drive Using DTC Strategy for the Minimization of CMV

K. Satyanarayana, P. Surekha, P. Vijaya Prasuna

Department of Electrical and Electronics Engineering, Pragati Engineering College, Surampalem

Article Info

Article history:

Received Feb 4, 2013

Revised Apr 23, 2013

Accepted May 26, 2013

Keyword:

CMV

DTC

FOC

Induction motor

Switching table

ABSTRACT

This paper presents a New FOC Approach of Induction Motor Drive using DTC Strategy for the Minimization of CMV (common mode voltage) with the switching tables for the generation of PWM signals. High performance induction motor drives require a better transient and steady state performance. To achieve high performance, there are two control strategies namely, field oriented control (FOC) and direct torque control (DTC) for induction motor drives. Though these two methods give better transient performance, the FOC needs reference frame transformations and DTC gives large steady state ripples. To overcome these drawbacks, this paper presents a novel FOC algorithm for induction motor drives, which combines the principles of both FOC and DTC. The proposed method uses a predetermined switching table instead of a much more time consuming pulse width modulation (PWM) procedure. This approach gives a quick torque response like DTC and gives reduced ripple like FOC. The switching table is based on the conventional DTC principle, which gives good performance with reduced common mode voltage variations. To validate the proposed method numerical simulations have been carried out and compared with the existing algorithms. The simulation results confirm the effectiveness of the proposed method.

Copyright © 2013 Institute of Advanced Engineering and Science.
All rights reserved.

Corresponding Author:

K. Satyanarayana, Ms P. Surekha and Ms P. Vijaya Prasuna

Departement of Electrical and Electronics Engineering,

Pragati Engineering College,

1-378, ADB Road, Surampalem, East Godavari District, Andhra Pradesh, India, 533437.

Email: snkola@gmail.com

1. INTRODUCTION

High performance induction motor drives require decoupled torque and flux control, which can be achieved by using the FOC strategy. Hence, this control technique is becoming popular in many industrial applications. In 1972 F. Blaschke presented a paper on FOC for induction motor [1]. Though FOC method gives decoupled control, it requires reference frame transformations, which increases the complexity of the system. To improve the performance of FOC strategy, many researchers have published various papers [2-4].

In 1985, Takahashi introduced direct torque control (DTC) scheme [5]. In contrast to FOC, DTC method requires the knowledge of stator resistance only. Hence it decreases the associated sensitivity to parameters variation and the elimination of speed information. DTC offers many advantages like absence of co-ordinate transformation and PWM modulator when compared with FOC strategy. Moreover, DTC is simple for the implementation, because it needs two hysteresis comparators and a lookup table only to control both the flux and torque. A detailed comparison between FOC and DTC methods has given in [6]. Though, DTC gives fast dynamic response, it gives large ripple in steady state current, torque and flux responses. The conventional FOC strategy uses hysteresis type current controllers to generate the PWM signals. However, this can be achieved by using the switching tables also [7].

Hence to overcome the drawbacks of FOC and DTC, this paper presents a new FOC scheme, which combines the principles of both FOC and DTC. The proposed algorithm uses sophisticated switching tables to generate the PWM signals to the inverter. Moreover, the proposed method does not require reference frame transformations and gives good steady state and transient performance.

2. CONVENTIONAL FOC ALGORITHM

Though the induction motor has a very simple construction, its mathematical model is complex due to the coupling factor between a large number of variables and the non-linearities. The FOC offers a solution to circumvent the need to solve high order equations and achieve an efficient control with high dynamic. The FOC algorithm controls the components of the motor stator currents, represented by a vector, in a rotating reference frame. In the FOC algorithm, the machine torque and rotor flux linkage are regulated by controlling the stator current vector. The stator current vector is resolved into a torque producing component (i_{qs}^*) and flux producing component (i_{ds}^*) in a rotating reference frame respectively. The flux component is oriented along the rotor flux linkage vector, and the torque component is perpendicular to the flux component. This decouples the torque control from the flux control. The electromagnetic torque expression for an induction motor is given as

$$T_e = \frac{3}{2} \frac{P}{2} \frac{L_m}{L_r} (\psi_{dr} i_{qs} - \psi_{qr} i_{ds}) \quad (1)$$

To achieve decoupling control, the entire rotor flux is aligned along d-axis and hence the q-axis flux component will become zero. With this, the torque expression can be modified as given in (2).

$$T_e = \frac{3}{2} \frac{P}{2} \frac{L_m}{L_r} (\psi_{dr} i_{qs}) \quad (2)$$

Hence, the total rotor flux can be given as in (3).

$$\psi_r = \psi_{dr} = L_m i_{ds} \quad (3)$$

From (3), it can be observed that the rotor flux is directly proportional to i_{ds}^* and is maintained constant. Hence, the torque linearly depends on i_{qs}^* , and provides a torque response as fast as the i_{qs}^* response. Then, the slip frequency can be evaluated from (4) and added to the rotor speed to generate unit vectors.

$$\omega_{sl} = \frac{L_m R_r}{L_r \Psi_r} i_{qs}^* \quad (4)$$

3. PROPOSED FOC ALGORITHM WITH DTC STRATEGY

The electromagnetic torque expression for an induction motor can also be represented as

$$T_e = \frac{3}{2} \frac{P}{2} \frac{L_m}{L_r} |\overline{\Psi_r}| |\vec{i}_s| \sin \eta \quad (5)$$

where η is the angle between stator current and rotor flux linkage vectors as shown in Figure 1.

From (5), it can be observed that the variations of torque depend on the variation of η . Hence, fast torque control can be achieved by rapidly changing ' η ' in the required direction. This is the basic principle of "proposed FOC". For a short time transient, the rotor flux is almost unchanged. Hence, the rapid changes of electromagnetic torque can be produced by rotating the d- and q- components of stator current vector in the required direction according to the demanded torque. Here, the d- and q-axis stator currents are fixed to the synchronously rotating reference frame. The approximate stator voltage expression can be represented as

$$\bar{v}_s = \frac{d\bar{\psi}_s}{dt} \quad (6)$$

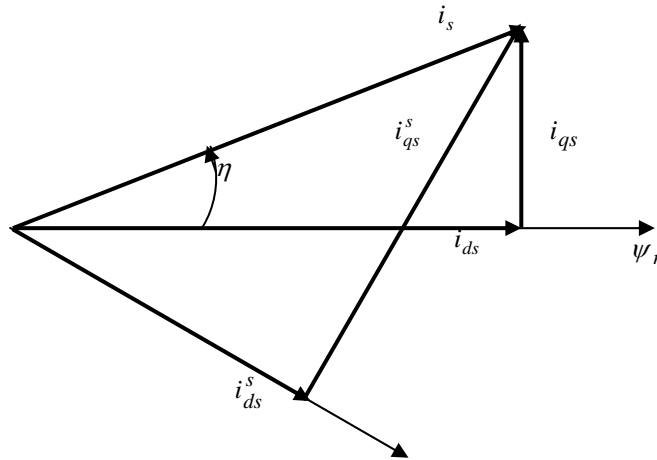

Figure 1. Representation of stator current and rotor flux linkage space vectors

The stator flux linkage space vector can be represented as

$$\bar{\psi}_s = L_s \bar{i}_s + \frac{L_m}{L_r} \psi_r - \frac{L_m^2}{L_r} \bar{i}_s \quad (7)$$

By assuming the rotor flux linkage vector as constant, the voltage expression can be simplified as follows.

$$\bar{v}_s = \frac{d\bar{\psi}_s}{dt} = \left(L_s - \frac{L_m^2}{L_r} \right) \frac{d\bar{i}_s}{dt} = \sigma L_s \frac{d\bar{i}_s}{dt} \quad (8)$$

For a short time interval of Δt , the stator current expression can be represented as given in (9).

$$\Delta \bar{i}_s = \frac{1}{\sigma L_s} \bar{v}_s \Delta t \quad (9)$$

Thus, the stator current space vector moves by $\Delta \bar{i}_s$ in the direction of the stator voltage space vector at a speed proportional to magnitude of voltage space vector. By selecting a suitable voltage vector it is then possible to change the stator current in the required direction. Decoupled control of the torque and stator flux is achieved by acting on the radial (flux component current \bar{i}_{ds}^s) and tangential (torque component current \bar{i}_{qs}^s) components of the stator current vector in the locus. These two components are directly proportional to the components of the stator voltage vector in the same directions. By assuming a slow motion of the rotor flux linkage space vector, if a forward active voltage vector is applied then it causes rapid movement of \bar{i}_s and torque increases with ' η '. On the other hand, when a zero voltage vector is used, \bar{i}_s becomes stationary and the electromagnetic torque will decrease, since rotor flux continues to move forward and the angle ' η ' decreases. Thus, it is possible to change the speed of stator current vector by changing the ratio between the zero and non-zero voltage vectors.

For a 3-phase, two-level voltage source inverter there are six active voltage space vectors and two zero voltage space vectors as shown in Figure 2.

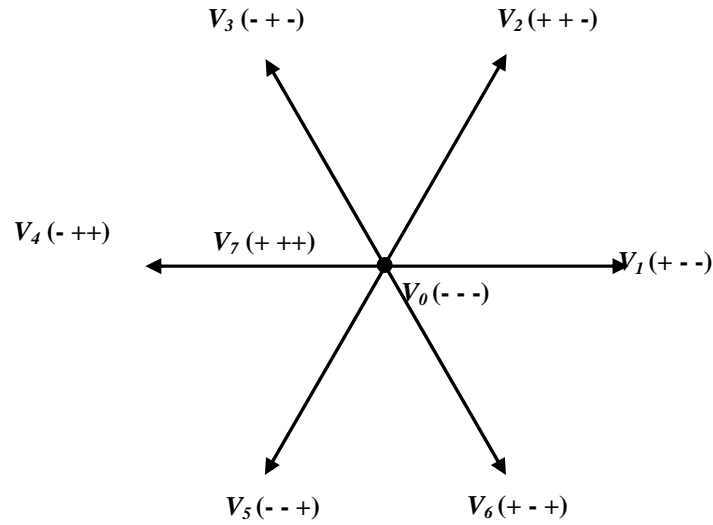

Figure 2. Inverter voltage space vectors

Depending on the position of stator current vector, it is possible to switch the appropriate voltage vectors to control both d- and q- axes stator currents. As an example if stator current vector is in sector I, then voltage vectors \bar{V}_2 and \bar{V}_6 can increase the flux component current \bar{i}_{ds} and \bar{V}_3 and \bar{V}_5 can decrease the \bar{i}_{ds} . Similarly \bar{V}_2 and \bar{V}_3 can increase the torque component current \bar{i}_{qs} and \bar{V}_5 and \bar{V}_6 can decrease the \bar{i}_{qs} as shown in Figure 3. Similarly the suitable voltage vectors can be selected for other sectors.

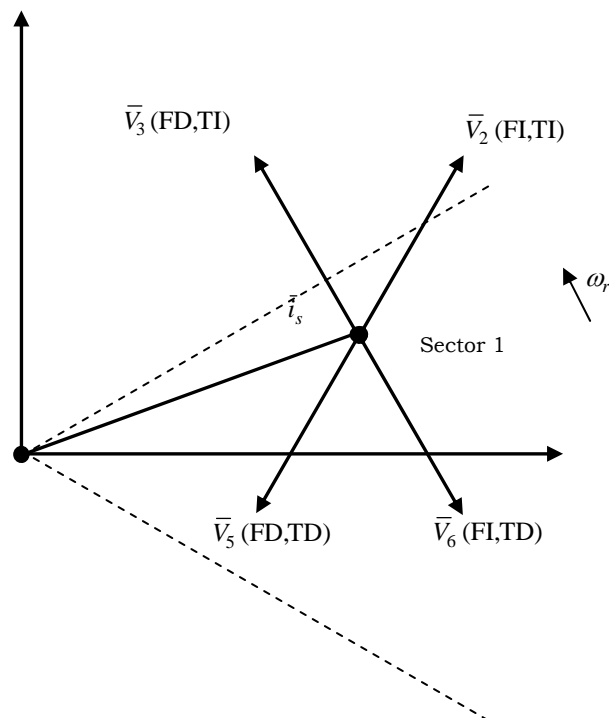

Figure 3. Selection of suitable voltage space vector in sector I (-30° to 30°)

As in DTC, the stator flux linkage and torque errors are restricted within their respective hysteresis bands, which are $2\Delta\bar{i}_{ds}$ and $2\Delta\bar{i}_{qs}$ wide respectively. If a flux component current (\bar{i}_{ds}) increase is required then $S_d = 1$; if \bar{i}_{ds} decrease is required then $S_d = 0$. The digitized output signals of the two level flux hysteresis controller (FHC) are defined as, if $\bar{i}_{ds} \leq \bar{i}_{ds}^* - \Delta\bar{i}_s$ then $S_d = 1$ and if $\bar{i}_{ds} \geq \bar{i}_{ds}^* + \Delta\bar{i}_s$ then $S_d = 0$. If a torque component current (\bar{i}_{qs}) increase is required then $S_q = 1$, if \bar{i}_{qs} decrease is required then $S_q = -1$, and if no change in \bar{i}_{qs} is required then $S_q = 0$. The digitized output signals of the three level torque hysteresis controller (THC) for the anticlockwise rotation or forward rotation can be defined as if $\bar{i}_{qs}^* - \bar{i}_{qs} \geq \Delta\bar{i}_{qs}$ then $S_q = 1$, if $\bar{i}_{qs} \geq \bar{i}_{qs}^*$ then $S_q = 0$ and for clockwise rotation or backward rotation if $\bar{i}_{qs}^* - \bar{i}_{qs} \leq -\Delta\bar{i}_{qs}$ then $S_q = -1$ and if $\bar{i}_{qs} \leq \bar{i}_{qs}^*$ then $S_q = 0$. Depending upon the S_d , S_q and the position of the stator current vector, the suitable switching voltage vector is determined from the switching table, which is given in Table 1.

Table 1. Optimum voltage vector switching table for reduced CMV

Sector		I	II	III	IV	V	VI
S_d	S_q						
1	1	\bar{V}_2	\bar{V}_3	\bar{V}_4	\bar{V}_5	\bar{V}_6	\bar{V}_1
	-1	\bar{V}_6	\bar{V}_1	\bar{V}_2	\bar{V}_3	\bar{V}_4	\bar{V}_5
	0	\bar{V}_3	\bar{V}_4	\bar{V}_5	\bar{V}_6	\bar{V}_1	\bar{V}_2
0	1	\bar{V}_3	\bar{V}_4	\bar{V}_5	\bar{V}_6	\bar{V}_1	\bar{V}_2
	-1	\bar{V}_5	\bar{V}_6	\bar{V}_1	\bar{V}_2	\bar{V}_3	\bar{V}_4

4. PROPOSED FOC ALGORITHM FOR REDUCED COMMON MODE VOLTAGE

The common mode voltage is the potential of the star point of the load with respect to the center of the dc bus of the VSI as shown in Figure 4

A set of phase voltage equations can be written as given in (10).

$$\begin{aligned}
 V_{an} &= V_{so} - V_{ao} \\
 V_{bn} &= V_{so} - V_{bo} \\
 V_{cn} &= V_{so} - V_{co}
 \end{aligned}
 \tag{10}$$

where V_{ao} , V_{bo} , V_{co} are inverter pole voltages and V_{so} is common mode voltage.

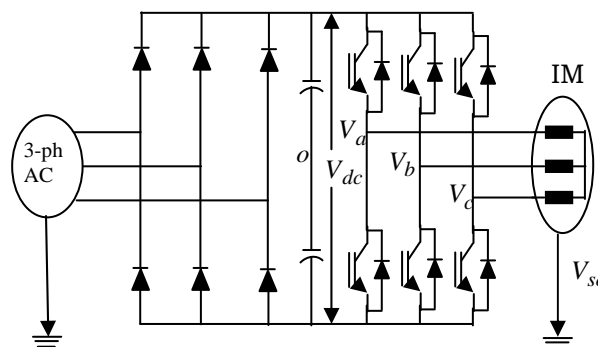

Figure 4. Three-phase VSI fed induction motor

Adding the set of equations of (10) and since $V_{an} + V_{bn} + V_{cn} = 0$, the common mode voltage in the motor is given by

$$V_{com} = V_{so} = \frac{V_{ao} + V_{bo} + V_{co}}{3} \quad (11)$$

Hence, if the drive is fed by balanced three phase supply, the common mode voltage is zero. But, the common mode voltage exists inevitably when the drive is fed from an inverter employing PWM technique because the VSI cannot produce pure sinusoidal voltages and has discrete output voltages. A detailed analysis is given in various papers [8-11].

It can be shown that the switching state and dc bus voltage decides the common mode voltage. There are eight available output voltage vectors in accordance with the eight different switching states of the inverter. According to the switching states of the inverter the common mode voltage can be expressed as given in (12).

$$V_{com} = V_{so} = \frac{V_{dc}}{3}(S_a + S_b + S_c) - \frac{V_{dc}}{2} \quad (12)$$

where S_a , S_b and S_c denotes the switching states of each phase. The common mode voltage for each inverter state is given in Table 2, which shows that, if only even or only odd voltage vectors are used, no common mode voltage variation is generated.

If a transition occurs from an even voltage vector to an odd one (or vice versa), a common mode variation of amplitude $V_{dc}/3$ is generated. If a transition from an odd (even) voltage vector to the zero (seventh) voltage vector occurs, a common variation $V_{dc}/3$ is generated. If a transition from an odd (even) voltage vector to the seventh (zero) voltage occurs, a common-mode variation of amplitude $2V_{dc}/3$ is generated. Finally, if a transition occurs from zero to seventh or vice versa, a common mode variation of amplitude V_{dc} is generated.

Table 2. Common mode voltage and output voltage generated by a switching state

Voltage vector	V_0 (000)	V_1 (100)	V_2 (110)	V_3 (010)	V_4 (011)	V_5 (001)	V_6 (101)	V_7 (111)
Common mode voltage	$-V_{dc}/2$	$-V_{dc}/6$	$-V_{dc}/6$	$-V_{dc}/6$	$-V_{dc}/6$	$-V_{dc}/6$	$-V_{dc}/6$	$-V_{dc}/2$

Therefore, from the point of view of common mode emissions, the worst case is transition between two zero voltage vectors. To minimize the generated common mode emissions of the drive, the exploitation of both the null voltage vectors (zero and seventh) should be avoided.

The block diagram of proposed DTC based FOC algorithm is as shown in Figure 5. As in conventional vector control, the proposed vector control algorithm generates d-axis and q-axis reference stator currents, which are at synchronously rotating reference frame. Then as in DTC the proposed vector control techniques uses two – level hysteresis controller and lookup table. Thus, the proposed algorithm eliminates time consuming PWM procedure. The generated d - and q - axis current commands are compared with their actual current values obtained from the measured phase currents. The current errors are used to produce d- and q-axes flags as inputs to the switching table. A third input to the table determines the sector through which the current vector is passing. Based on the outputs of hysteresis controllers and position of the stator current vector, the optimum switching table will be constructed. This gives the optimum selection of the switching voltage space vectors for all the possible stator current vector positions.

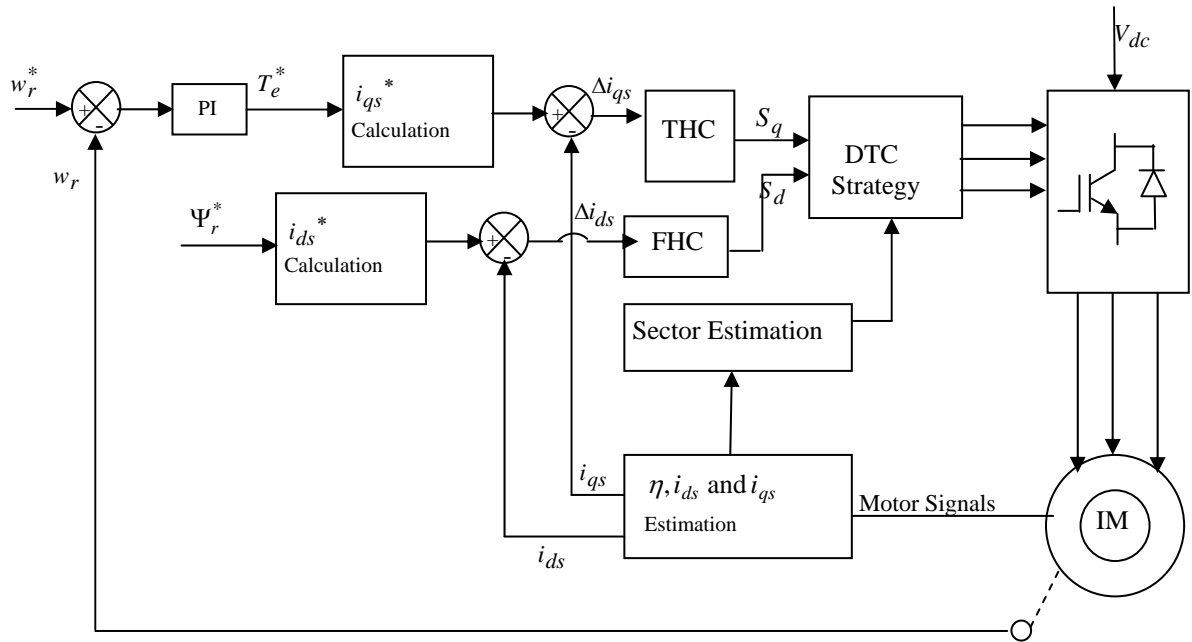

Figure 5. Block diagram of proposed DTC based FOC based induction motor drive

5. SIMULATION RESULTS AND DISCUSSIONS

To validate the proposed algorithms, numerical simulation studies have been carried out by using Matlab-Simulink. For the simulation studies the dc link voltage is taken as 540V. The parameters of the induction motor used in this paper are $R_s = 1.57\text{ohm}$, $R_r = 1.21\text{ohm}$, $L_m = 0.165\text{H}$, $L_s = 0.17\text{H}$, $L_r = 0.17\text{H}$ and $J = 0.089\text{Kg-m}^2$. The simulation results of proposed algorithms are shown from Figure 6 – Figure 10.

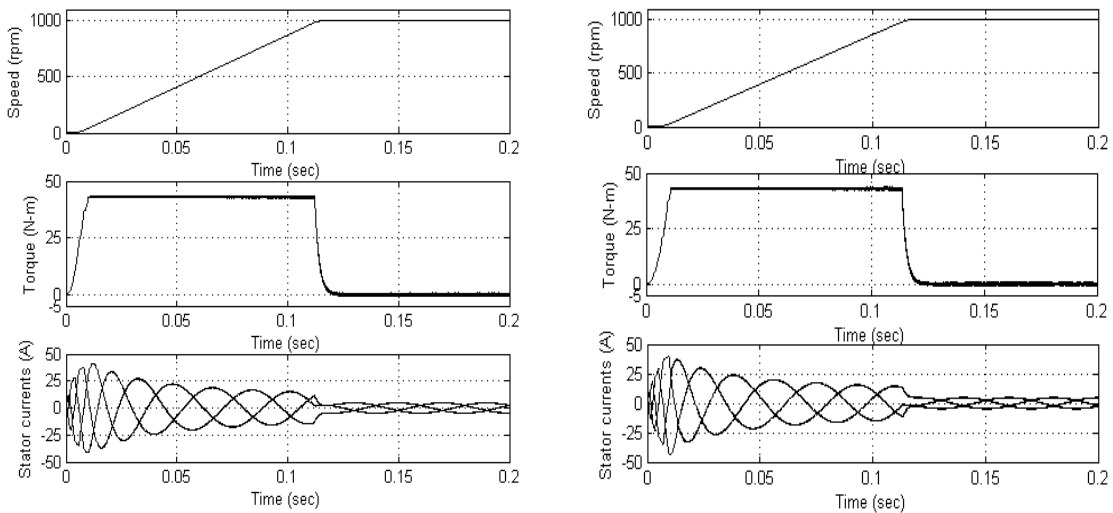

Figure 6. Starting transients in conventional FOC and proposed DTC based FOC algorithms

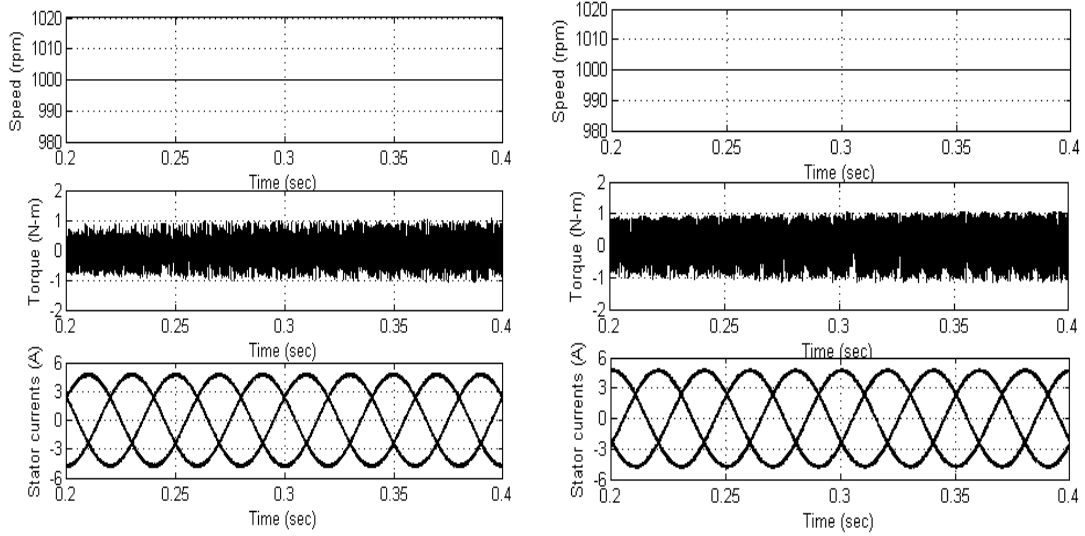

Figure 7. Steady state plots for conventional FOC and proposed DTC based FOC algorithms

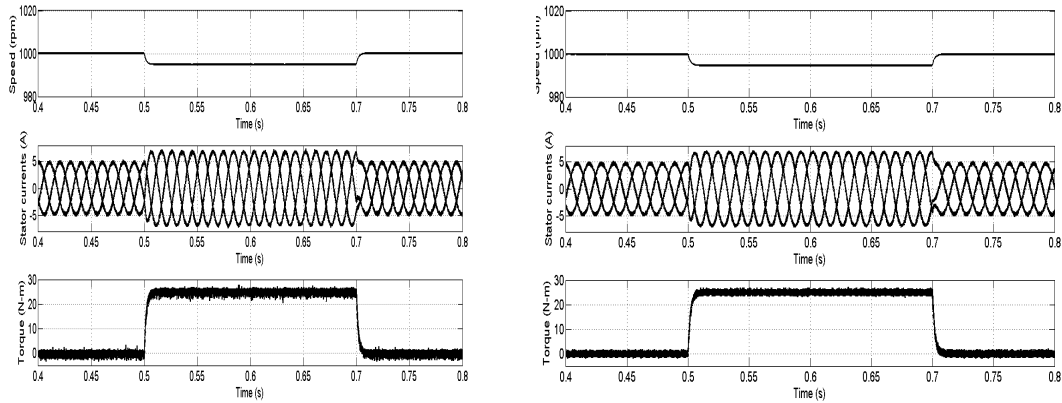

Figure 8. Transients in speed, torque and currents during step change in load (a load torque of 25 N-m is applied at 0.5 s and removed at 0.7 s) for conventional FOC and proposed DTC based FOC algorithms

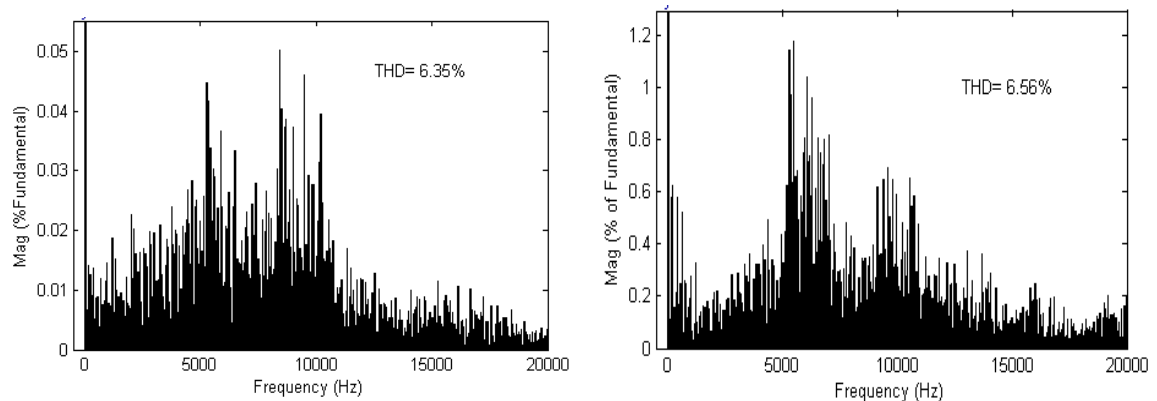

Figure 9. Harmonic spectra of steady state line current in conventional FOC and proposed DTC based FOC algorithms

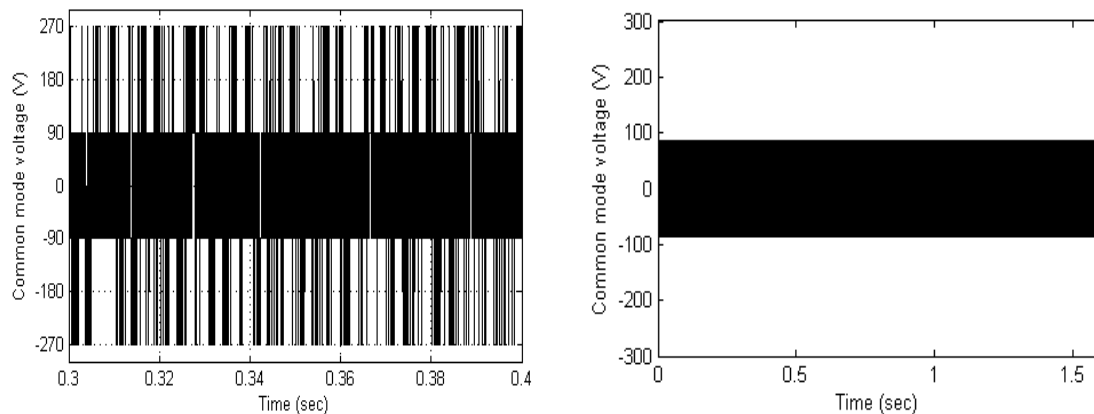

Figure 10. common mode voltage variations in conventional FOC and proposed DTC based FOC algorithms

From the results it can be observed that the proposed algorithm gives good performance during the transient and steady state conditions. The proposed algorithm has been developed by using the switching tables in order to reduce the common mode voltage variations, the zero voltage vectors are eliminated and hence this algorithm gives slightly increased ripple in current when compared with the conventional algorithm.

6. CONCLUSION

The FOC algorithm is becoming popular in high-performance applications. To eliminate the reference frame transformations in the conventional FOC algorithm, novel FOC algorithm is presented in this paper by using the switching tables. The proposed algorithm combines the basic principles of FOC and direct torque control algorithms. It uses the instantaneous errors in d- and q axes stator currents and sector information to select the suitable voltage vector. Hence, the proposed algorithm uses a predetermined switching table instead of a much more time consuming PWM procedure in conventional FOC algorithm. In order to reduce the common mode voltage variations did not use the zero voltage vectors. From the simulation results it can be observed that the proposed algorithm will give good performance with small increment in the steady state current ripple with drastic reduction in common mode voltage variations when compared with the conventional FOC algorithm.

REFERENCES

- [1] F Blaschke. "The principle of field orientation as applied to the new transvector closed loop control system for rotating-field machines". *Siemens Review*. 1972, pp 217-220.
- [2] W Leonhard. "30 years of space vectors, 20 years of field orientation, 10 years of digital signal processing with controlled AC-drives, a review (Part 2)". *EPE Journal*. No. 2, Oct, 1991, pages 89-102.
- [3] JA Santisteban, and RM Stephan. "FOC methods for induction machines: an overview". *IEEE Trans. On Education*. vol. 44, no. 2, pp. 170-175, May 2001.
- [4] Isao Takahashi and Toshihiko Noguchi. "A new quick-response and high-efficiency control strategy of an induction motor". *IEEE Trans. Ind. Appl.* vol. IA-22, no.5, Sep/Oct 1986, pp. 820-827.
- [5] Domenico Casadei, Francesco Profumo, Giovanni Serra, and Angelo Tani. "FOC and DTC: Two Viable Schemes for Induction Motors Torque Control". *IEEE Trans. Power Electron.* vol. 17, no.5, Sep, 2002, pp. 779-787.
- [6] Marian P Kaimierkowski, Maciej A Dzieniakowski, and Waldemar Sulkowski. "Novel Space Vector Based Current Controllers for PWM-Inverters". *IEEE Trans. Power Electronics*. vol.6, no.1, Jan, 1991, pp. 158-166.
- [7] Maurizio Cirrincione, Marcello Pucci, Gianpaolo Vitale and Giansalvo Cirrincione. "A new direct torque control strategy for the minimization of common-mode emissions". *IEEE Trans. Ind. Appl.* vol. 4, no. 2, Mar/Apr, 2006.
- [8] YS Lai, PS Chen, HK Lee, and J Chou. "Optimal common-mode voltage reduction PWM technique for inverter control with consideration of the dead-time effects—Part II: Applications to IM drives with diode front end". *IEEE Trans. Ind. Appl.* vol. 40, no. 6, pp. 1613–1620, Nov./Dec. 2004.
- [9] J Zitzelberger and W Hofmann. "Reduction of bearing currents in inverter fed drive applications by using sequentially positioned pulse modulation". *EPE J*. vol. 14, no. 4, pp. 19–25, 2004.
- [10] Emre Ün and AM Hava. "A high performance PWM algorithm for common mode voltage reduction in three-phase voltage source inverters". in Proc. IEEE PESC 2008, pp. 1528–1534.

- [11] AM Hava, and Emre Ün. "Performance Analysis of Reduced Common-Mode Voltage PWM Methods and Comparison With Standard PWM Methods for Three-Phase Voltage-Source Inverters". *IEEE Trans. Power Electron.* vol.24, no.1, pp. 241-252, Jan, 2009.

BIOGRAPHIES OF AUTHORS



Prof. K. Satyanarayana obtained M.Tech degree in Power Electronics from JNTU College of Engineering, Hyderabad in 2003. He is presently working as Professor and H.O.D. of the Department of Electrical and Electronics Engineering, Pragati Engineering College, Surampalem, Peddapuram, A.P., INDIA. He has submitted Doctoral degree at J.N.T.U. College of Engineering, Kakinada. He presented 20 research papers in various national and international journals and conferences. His research interests include Power Electronic Drives, PWM and Vector Control techniques.



Ms P. Surekha graduated from JNTU college of Engineering, Kakinada in the year 2005, She is presently Pursuing M.Tech in the Department of Electrical and Electronics Engineering, Pragati Engineering college, Surampalem, Peddapuram. Her research areas include Power Electronic Drives, Fuzzy and FOC techniques.



Ms P. Vijaya Prasuna graduated from JNT University, Hyderabad in the year 2005 and Post graduated from JNTU, Kakinada. She is presently working as Assistant Professor in the Department of Electrical and Electronics Engineering, Pragati Engineering college, Surampalem, Peddapuram. She presented many research papers in various national and international conferences and journals. Her research areas include Power Electronic Drives, PWM techniques and active and passive filters designing.