

## A Comparative Study of Z-Source Inverter Fed Three-Phase IM Drive with CSI and VSI fed IM

Deepak Kumar, Zakir Husain

Departement of Electrical Engineering, National Institute of Technology, Hamirpur (HP), India

---

### Article Info

#### Article history:

Received May 11, 2013

Revised July 10, 2013

Accepted July 28, 2013

---

#### Keyword:

Current Source Inverter (CSI)

Induction Machine (IM)

Load Torque (Tl)

PWM

Shoot- through state

Voltage Source Inverter (VSI)

Z-source inverter

---

### ABSTRACT

This paper cite comparative performance characteristics of Z-Source inverter fed IM drives with mostly used VSI & CSI fed IM drives. ZSI has both voltages buck and boost capabilities as they allow inverters to be operated in the shoot through state. It employs an exclusive Z-Source network (LC component) to dc-link the main inverter circuit to the power source. By controlling the shoot-through duty cycle, the inverter system using IGBTs reduces the line harmonics, improves power factor, increases reliability and extends output voltage range. Simulation results are given to compare the behavior of conventional and proposed topology and also demonstrate the new features of the improved topology i.e ZSI fed IM. Simulation results of ZSI fed IM gives different performance characteristics as compared to VSI & CSI fed IM drives as shown for stator & rotor current characteristics, speed characteristics, torque characteristics which put a gloss on the VSI & CSI fed IM performance.

Copyright © 2013 Institute of Advanced Engineering and Science.

All rights reserved.

---

### Corresponding Author:

Deepak Kumar,

Departement of Electrical Engineering,

National Institute of Technology,

Hamirpur, Himachal Pradesh , India-177005

Email: dkaroraelectrical@gmail.com, timothyarora@gmail.com

---

## 1. INTRODUCTION

This paper presents a functional model of Z-source inverter and VSI using switching function based on PWM approach concept is studied and the Simulation of the developed model is done with the help of MATLAB/Simulink. The conventional inverters used for Adjustable Speed Drives (ASDs) are voltage source inverter (VSI) and current source inverter (CSI) which consists of a diode rectifier front end, dc link and Inverter Bridge. The voltage source inverter is a buck converter that can only produce an ac voltage limited by the dc link voltage. Because of using the DC link reactor in the CSI drives, the rate of rise of current under short circuit will be limited. So the drives can be easily protected under short circuit. On the other hand, the presence of DC link reactor will result in slow dynamic response of the drive [1, 4]; hence CSI fed IM drives are used where fast dynamic response is not needed. The main disadvantage of CSI fed IM drive is nonlinearity and complexity. Because of this nature, the voltage source inverter and current source inverter are characterized by relatively low efficiency because of switching losses and considerable EMI generation. The voltage source inverter requires an output LC filter to provide sinusoidal voltage compared with current source inverter. The LC filters causes additional power loss and control complexity. The voltage source converter is widely used. However, the ac output voltage is limited below and cannot exceed the dc bus voltage or the dc bus voltage has to be greater than the ac input voltage. For applications where over drive is desirable and the available dc voltage is limited, an additional dc-dc boost converter is needed to obtain a desired ac output. The additional power converter stage increases system cost and lower the efficiency.

The upper and lower devices of each phase leg cannot be switched on simultaneously, otherwise, a shoot through would occur and destroy the devices [1]. Dead-time to block both upper and lower devices has to be provided in the voltage source converter, which causes waveform distortion, etc.

Alternatively, Current source inverters could be employed with boost control. A dc current source feeds the main converter circuit, a three-phase bridge. The dc current source can be a relatively large dc inductor fed by a voltage source such as a battery or diode rectifier. Six switches are used in the main circuit; each is composed traditionally by a semiconductor switching device with reverse block capability. However, the current source converter has the following conceptual and theoretical barriers and limitations

At least one of the upper devices and one of the lower devices have to be gated on and maintained on at any time. Otherwise, an open circuit of the dc inductor would occur and destroy the devices. Overlap time for safe current commutation is needed in the current source converter, which also causes waveform distortion, etc.

In addition, both the voltage source converter and the current source converter have the following common problems. They are either a boost or a buck converter and cannot be a buck-boost converter. That is, the output voltage range is limited to either greater or smaller than the input voltage. The main circuit is not being interchangeable. In other words, neither the voltage source converter main circuit can be used for the current source converter and nor vice versa. They are vulnerable to EMI noise in terms of reliability.

## 2. Z SOURCE INVERTER

To overcome the problems in the conventional inverters there is an Impedance source inverter which is used. This impedance source inverter consists of a unique impedance network coupled with the inverter main circuit to the power source. The Z-source inverter advantageously utilizes the shoot through states to boost the dc bus voltage by gating on both the upper and lower switches of the same phase leg [1, 11]. Shoot through mode allows simultaneous conduction of devices in same phase leg. Therefore, a Z-source inverter can boost or buck voltage to a desired output voltage that is greater/less than the dc bus voltage based on the boost factor [18]. The inverter bridge is equivalent to a short circuit when the inverter bridge is in the shoot-through zero state, as shown in Figure 1, whereas the inverter bridge becomes an equivalent current source as shown in Figure 2 [1]. The diode is used to prevent the reverse flow of current in the circuit. The energy which is stored in the inductors in the shoot through state when both the switches on the same leg of the inverter are gated is then transferred in addition to the supply voltage to the load side when normal gating of the inverter switches occur [5].

Z-source inverter based induction motor drives provides a low cost and highly efficient single stage structure for reliable operation.

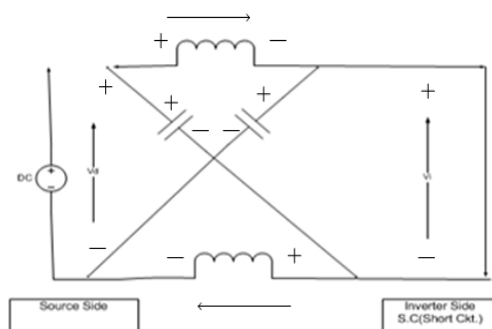

Figure 1. Equivalent Circuit of ZSI viewed from dc Link when Bridge in Shoot through State

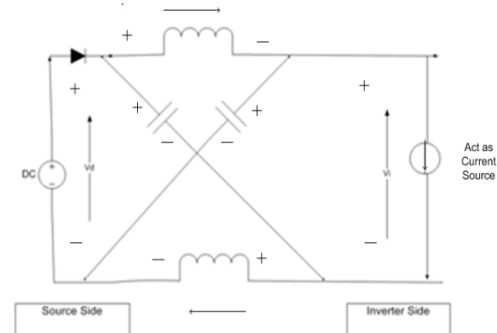

Figure 2. Equivalent Circuit when ZSI in Non Shoot through State

## 3. MODULATION METHODS

In Pulse Width Modulation variable speed drives are increasingly applied in many new industrial applications that require superior performance. A number of Pulse width modulation (PWM) schemes are used to obtain variable voltage and frequency supply. The most widely used PWM schemes for three-phase voltage source inverters are carrier-based sinusoidal PWM i.e. used here. In this method, a fixed dc input voltage is given to the inverter and a controlled ac output voltage is obtained by adjusting the on and off

periods of the inverter components. The carrier-based PWM technique fulfils such a requirement as it defines the on and off states of the switches of one leg of a VSI by comparing a modulating signal  $v_c$  (desired ac output voltage) and a triangular waveform  $v_\Delta$  (carrier signal) [7, 11]

For VSI, Amplitudes of the *triangular wave* (carrier) and sine wave (modulating) are compared to obtain *PWM* waveform as shown in Fig 3. Similar PWM control technique is used for CSI fed IM drive which is shown in Figure 4 for G1 to G6 of all the three legs.

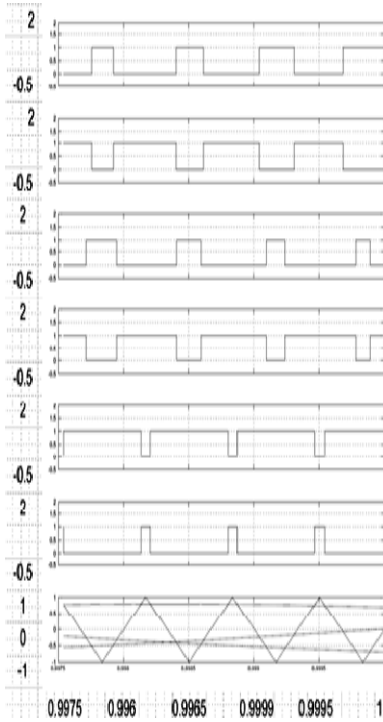

Figure 3. PWM for VSI

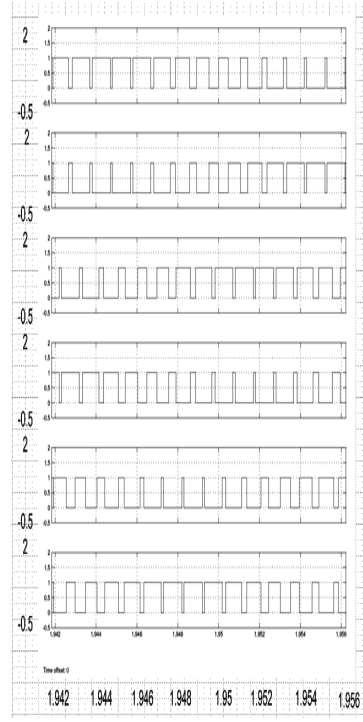

Figure 4. PWM for CSI

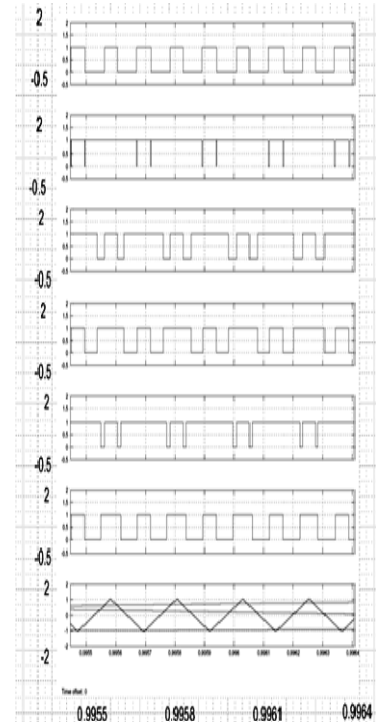

Figure 5. PWM for z Source Inverter

The Z-source inverter intentionally utilizes the shoot-through zero states to boost dc voltage and produce an output voltage greater than the original dc voltage. But the shoot-through zero states do not affect the PWM control of the inverter, because it equivalently produces the same zero voltage to the load terminal but to achieve the high output voltage, it is required to increase the shoot-through duty ratio. So, Z-source inverter shoot-through states are also inserted using 0.626 as deviation for operating the switch of the same leg simultaneously as shown in Figure 5.

#### 4. MATLAB MODELS

In VSI type of inverter, input voltage is maintained constant and the amplitude of output voltage does not depend on the load. However, the waveform of load current as well as its magnitude depends upon the nature of the load impedance.

The upper and lower power switches of the same leg are complementary in operation, i.e. if the upper switch is ON, the lower must be OFF, and vice-versa.

VSI model, CSI Model & ZSI model are shown in Figure 6, 7 & 8 respectively, and their output under under load, rated load, overload & step load is shown further for comparison between them.

In this study, reduced order dynamic models of a CSI-IM drive have been developed, which is shown in Figure 6 [14].

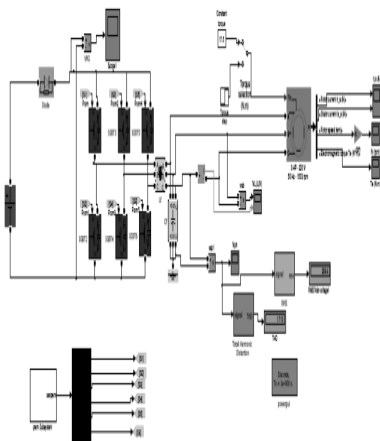

Figure 6. VSI Model

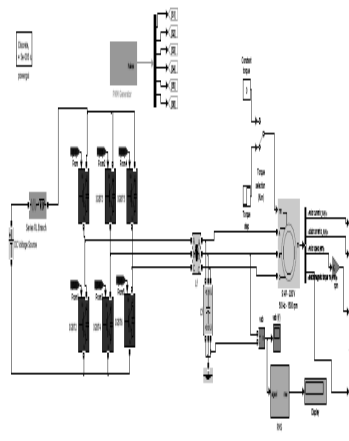

Figure 7. CSI Model

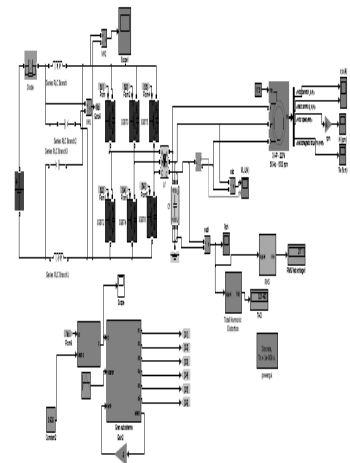

Figure 8. ZSI Model

As shown Z source inverter use a unique impedance network, coupled between the power source and converter circuit, to provide both voltage buck and boost properties, which cannot be achieved with conventional voltage source and current source inverters.

**5. SIMULATION RESULTS**

**A. Rotor & Stator Currents Comparison**

**VSI:**

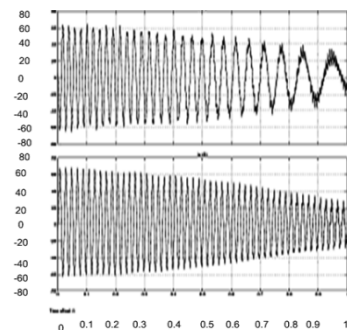

Figure 9. Ir and Is at rated load Tl=17.5 Nm for VSI fed IM

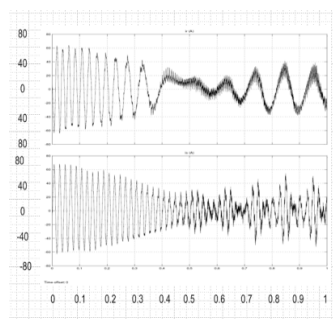

Figure 10. Ir and Is at no load T=0 Nm for VSI fed IM

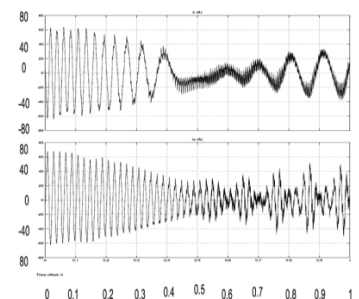

Figure 11. Ir and Is at T=1 Nm for VSI fed IM

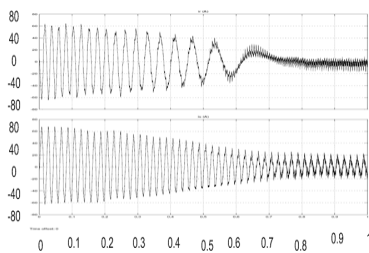

Figure 12. Ir and Is at Tl=10 Nm for VSI fed IM

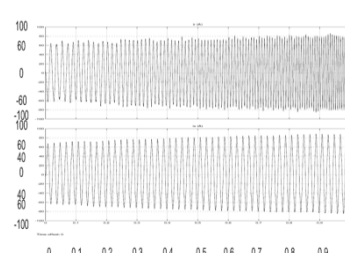

Figure 13. Ir and Is at Tl=50 Nm for VSI fed IM

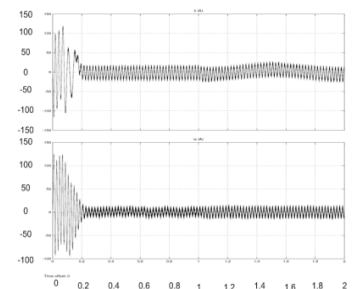

Figure 14. Ir and Is with step load torque from 0 to 10 Nm at t=1 sec for VSI fed IM

The result of rotor current and stator current for VSI, CSI & ZSI under different load condition are shown from Figure 9 to 14, 15 to 19 & 20 to 26 respectively for 1 sec time duration (x axis). This clearly shows that with Z source inverter, settling time for current is decreased as compared to traditional CSI & VSI i.e. In case of ZSI, current reaches to its steady state value soon.

**CSI:**

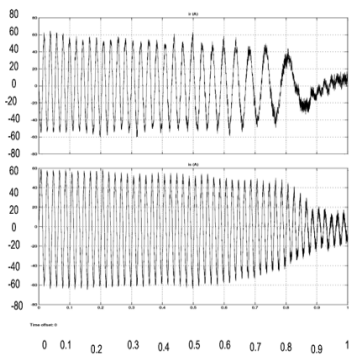

Figure 15. Ir and Is at Tl= 15 Nm for CSI fed IM

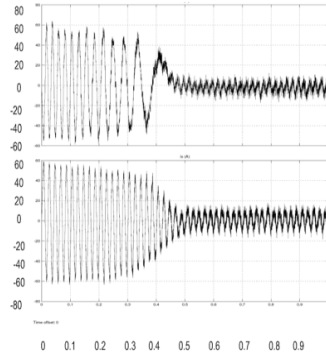

Figure 16. Ir & Is at 1 Nm CSI fed IM

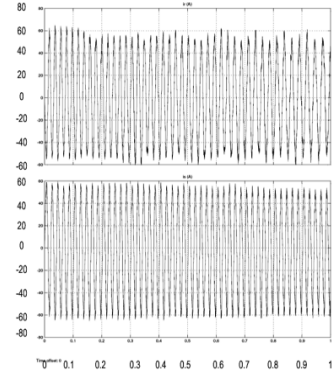

Figure 17. Ir and Is at 20 Nm for CSI fed IM

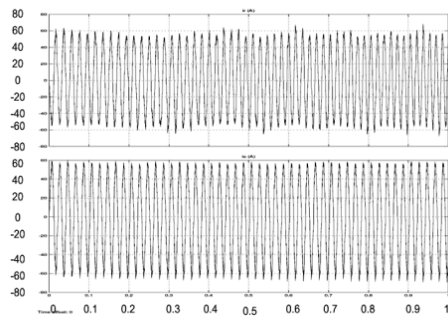

Figure 18. Ir and Is at 25 Nm CSI fed IM

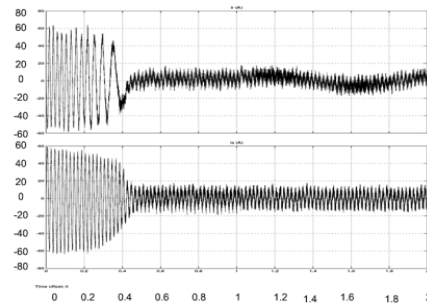

Figure 19. Ir and Is for step load at t=1sec for Tl=0 to 10 Nm for CSI fed IM

It is also clearly seen that VSI has more ripple component as compared to ZSI and it increases in hazardous manner for overload case in VSI as compared to ZSI. With ZSI fed IM inrush current and harmonic current is reduced as shown.

**ZSI:**

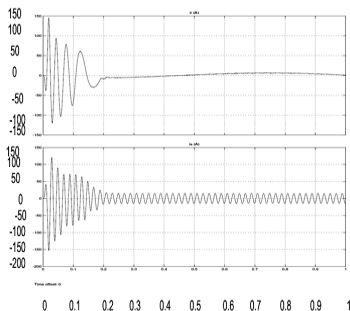

Figure 20. Ir and Is at Rated Load T=17.5 Nm for ZSI

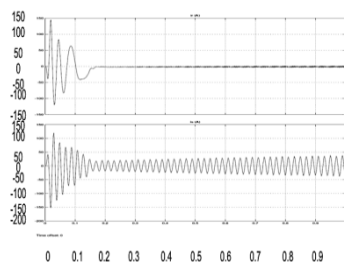

Figure 21. Ir and Is at Tl=0 Nm for ZSI fed IM

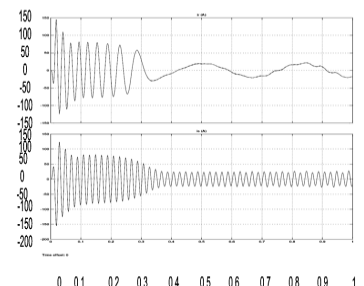

Figure 22. Ir and Is at T=50 Nm i.e. Overload for ZSI

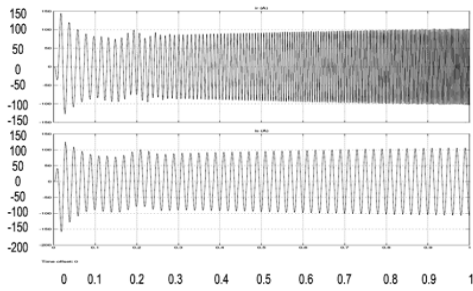

Figure 23. Ir and Is at T=100 Nm i.e. overload ZSI fed IM

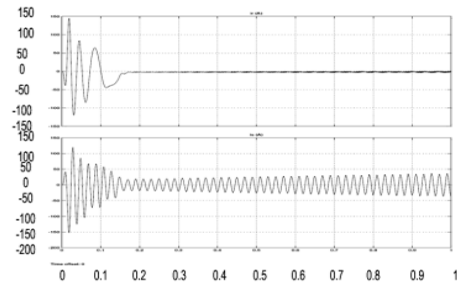

Figure 24. Ir and Is at t=1 Nm under load for ZSI fed IM

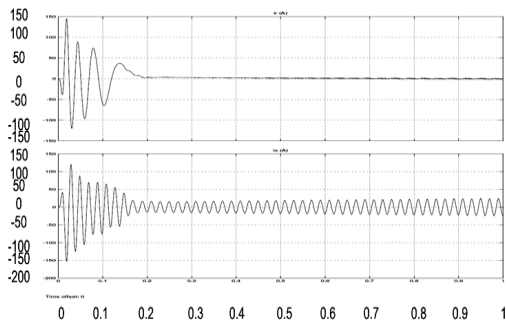

Figure 25. Ir and Is at t=10 Nm for under Load ZSI fed IM

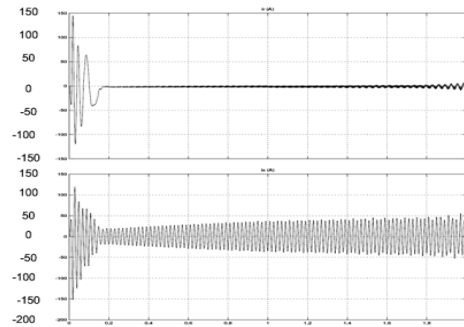

Figure 26. Ir and Is with Step Torque from 0 to 10 Nm at t= 1sec in Case of ZSI fed IM

For step load at t=1 sec, rotor and stator currents shown for VSI, CSI and ZSI in Figure 14, 19 & 26 respectively signify that the response of ZSI fed IM shows less ripple and accept the load more frequently. The rotor heating is also reduced due to reduction in rotor currents. Also, it is possible to limit the peak stator phase currents to tolerable levels.

**B. Speed Comparison**

**VSI:**

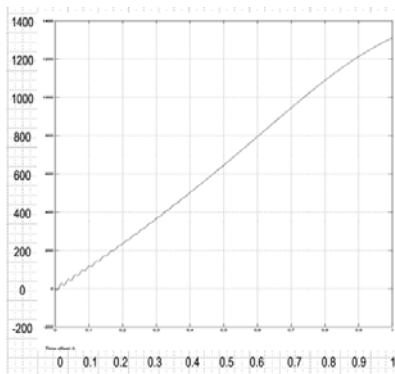

Figure 27. Speed at T=17.5 Nm i.e. rated load for VSI fed IM

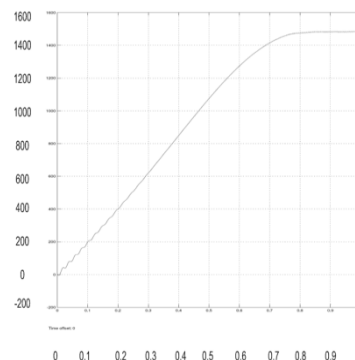

Figure 28. Speed at T=10 Nm for VSI fed IM

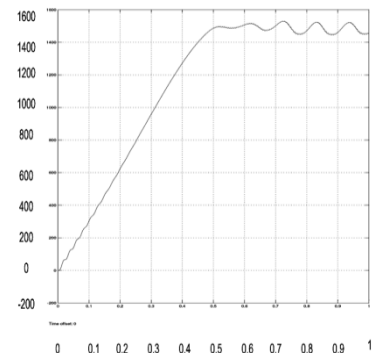

Figure 29. Speed at T=0 Nm i.e. No load for VSI fed IM

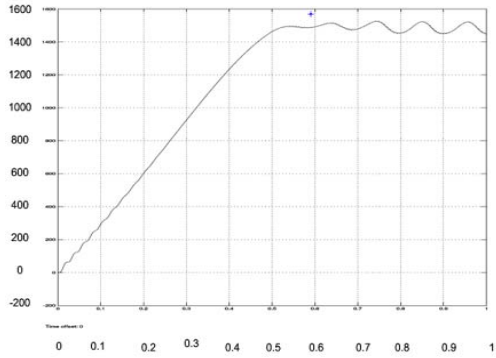

Figure 30. Speed at Tl=1 Nm for VSI fed IM

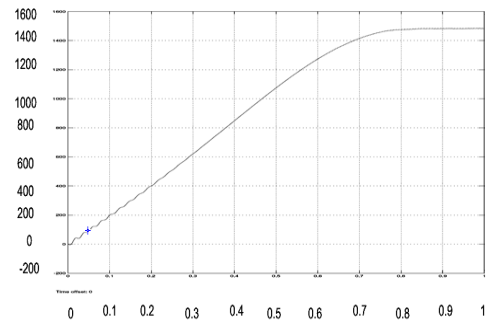

Figure 31. Speed at Tl=10 Nm for VSI fed IM

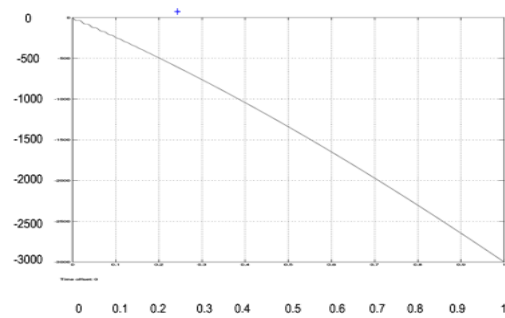

Figure 32. Speed at Tl=50 Nm for VSI fed IM

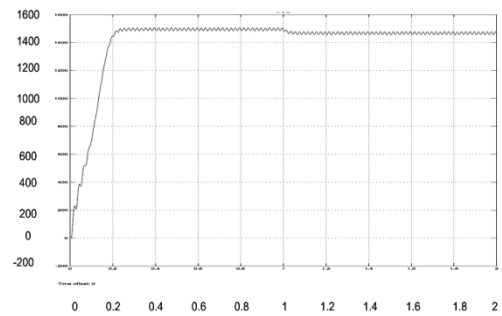

Figure 33. Speed with step load 0 to 10 Nm at t=1sec for VSI fed IM

Speed of induction motor with voltage source inverter fed induction motor under different load torque condition is shown from Figure 27 to Figure 33.

**CSI:**

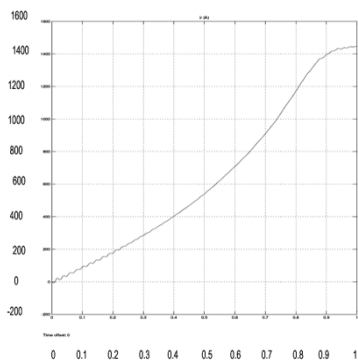

Figure 34. Speed at Tl=15 Nm for CSI fed IM

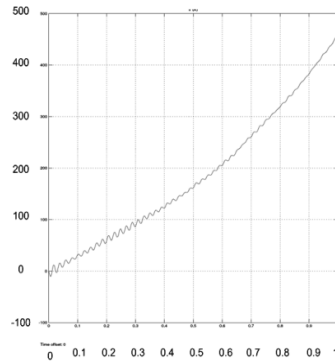

Figure 35. Speed at 20 Nm CSI fed IM at Tl= 20 Nm, CSI fed IM takes more time to attain the required speed

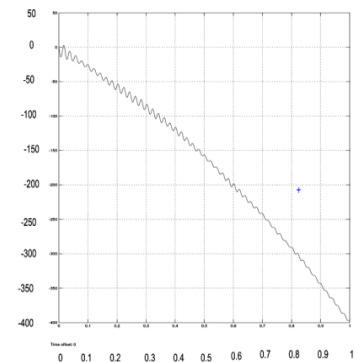

Figure 36. Speed at Tl= 25 Nm CSI fed IM at load Torque 25 Nm CSI fed IM fails to attain the required speed.

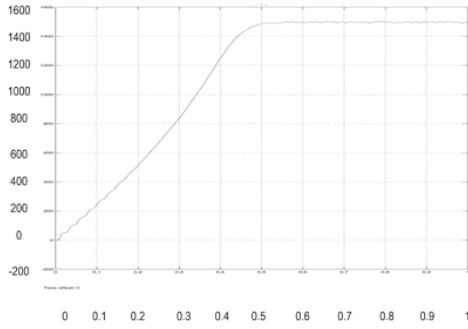

Figure 37. Speed at Load Torque 1 Nm CSI fed IM

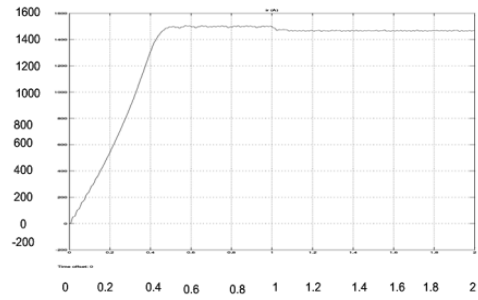

Figure 38. Speed for Step Load Torque at  $t=1\text{sec}$ ,  $T_l=0$  to 10 Nm for CSI fed IM

The output of inverter is used to control the speed of an induction motor. The speed responses of z source inverter fed induction motor are shown further.

**ZSI:**

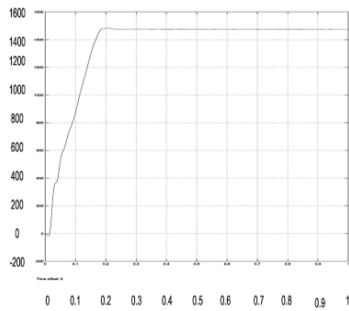

Figure 39. Speed at Rated Load  $T_l=17.5$  Nm for ZSI fed IM

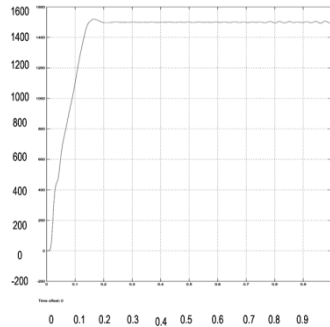

Figure 40. Speed at No Load for ZSI fed IM

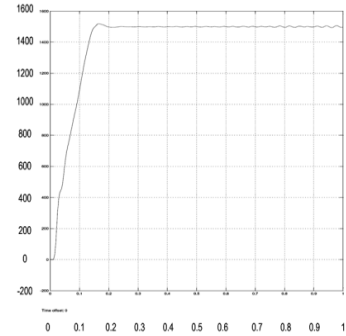

Figure 41. Speed under Load  $T_l=1\text{Nm}$  for ZSI fed IM

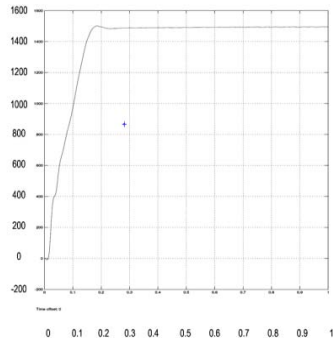

Figure 42. Speed under Load at  $T_l=10$  Nm for ZSI fed IM

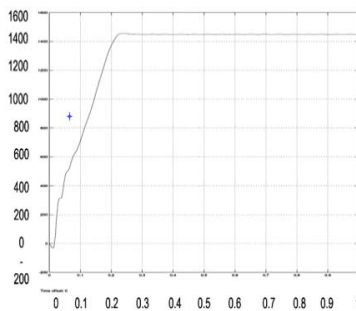

Figure 43. Speed at Overload,  $T_l=30$  Nm for ZSI fed IM

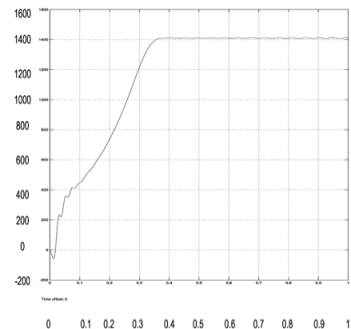

Figure 44. Speed at Overload,  $T_l=50$  Nm for ZSI fed IM



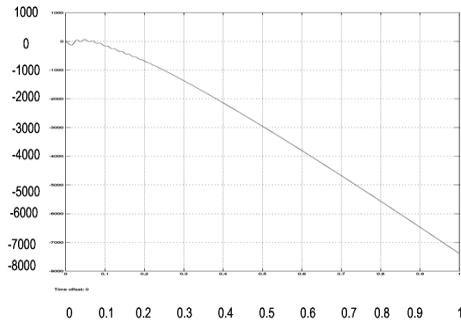

Figure 45. Speed at Overload,  $T_l=100\text{Nm}$  for ZSI fed IM at Load Torque =  $100\text{Nm}$ , ZSI fed IM fails.

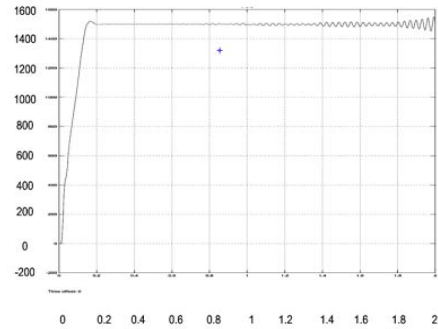

Figure 46. Speed Step Torque 0 to 10 Nm for ZSI fed IM

The result of speed under different load condition for VSI, CSI and ZSI is shown from Figure 27 to Figure 33, Figure 34 to Figure 38 & Figure 39 to Figure 46 respectively. When the motor is fed by z-source inverter then its speed increases and settling time decreases. Also, motor is able to run at rated speed for heavy load in case of ZSI. For step load at  $t=1$  sec shown for CSI, VSI & ZSI fed IM indicates that speed variation and time taken by ZSI fed IM to new load is quite less as compared to VSI & CSI. CSI takes larger time to adjust to new load as compared to VSI & ZSI.

**C. Torque Comparison**

The torque output curves of induction motor under different load condition for VSI, CSI and ZSI are shown from Figure 47 to Figure 51, Figure 52 to Figure 57 and from Figure 58 to Figure 65 respectively.

**VSI:**

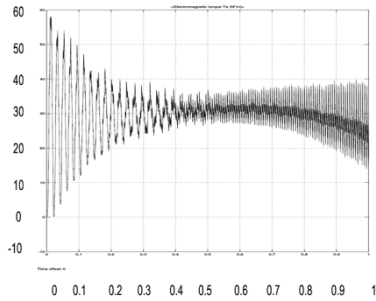

Figure 47. Torque at  $T=17.5$  Nm for VSI fed IM

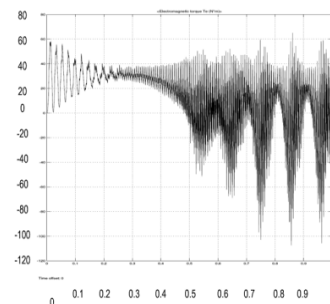

Figure 48. Torque at  $T=0$  Nm for VSI fed IM

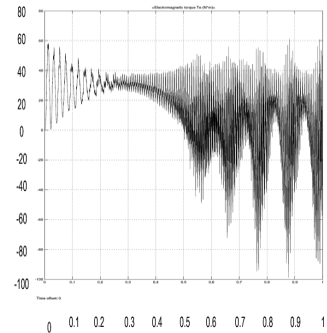

Figure 49. Torque at  $T=1$  Nm for VSI fed IM

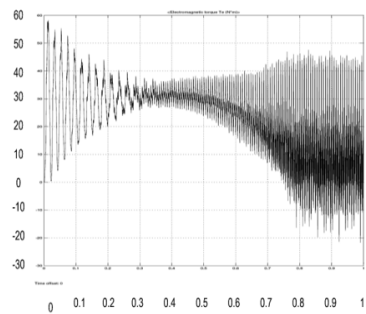

Figure 50. Torque at  $T=10$  Nm for VSI fed IM

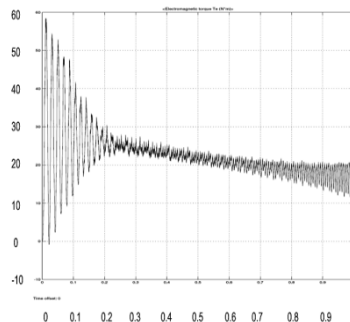

Figure 51. Torque at  $T=50$  N for VSI fed IM

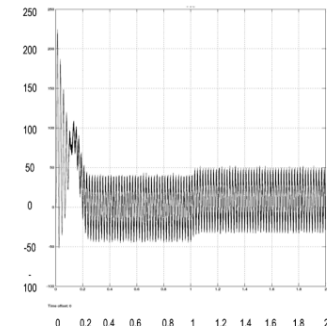

Figure 52. Torque with step load 0 to 10 Nm at  $t=1$  sec for VSI fed IM

**CSI:**

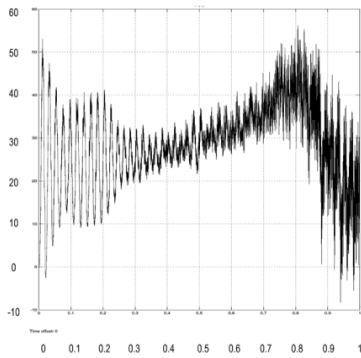

Figure 53. Torque at 15 Nm for CSI fed IM

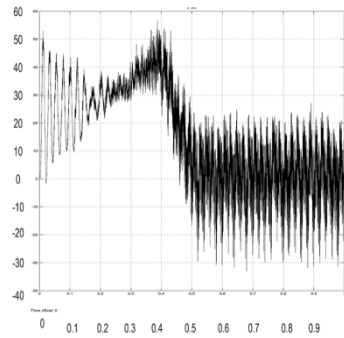

Figure 54. Torque at 1Nm CSI fed IM

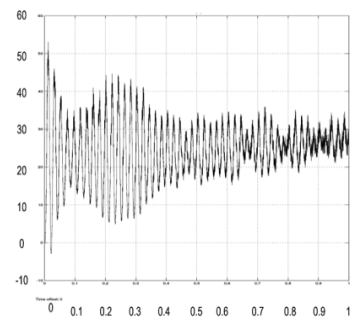

Figure 55. Torque at 20 Nm CSI fed IM Drive

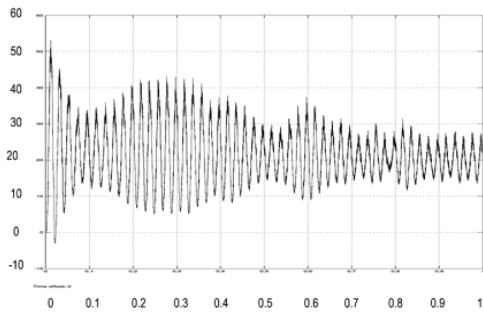

Fig 56. Torque at TI=25Nm CSI fed IM drive

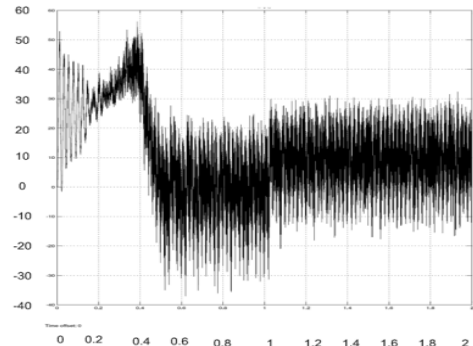

Fig 57. Torque for step load 0 to 10 Nm at t= 1sec for CSI fed IM

**ZSI:**

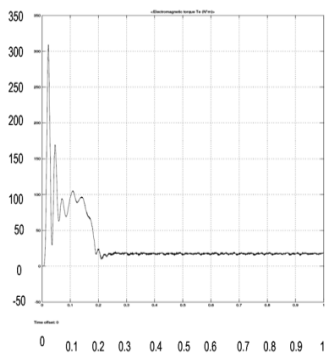

Figure 58. Torque at rated load 17.5Nm for ZSI fed IM

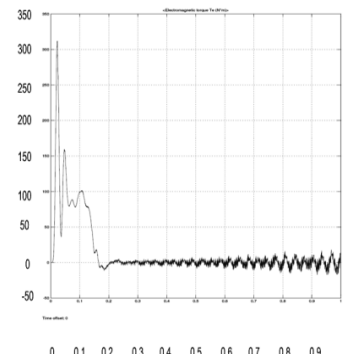

Figure 59. Torque at no load for ZSI fed IM

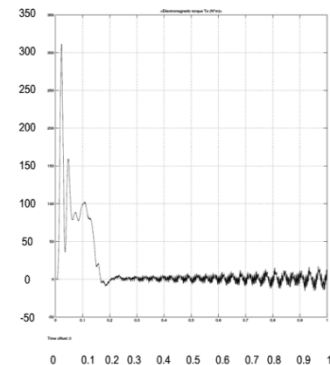

Figure 60. Torque at under load T=1 Nm for ZSI fed IM

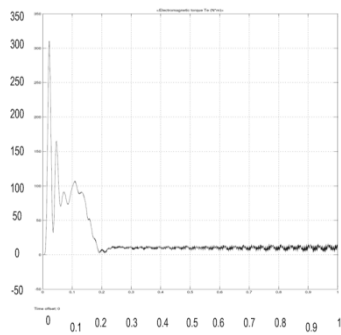

Figure 61. Torque at under load  $T=10\text{Nm}$  for ZSI fed IM

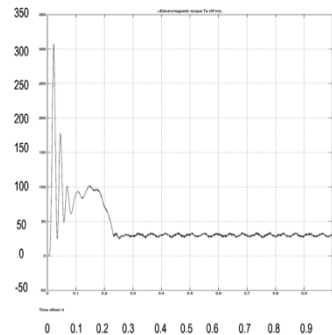

Figure 62. Torque at overload  $T=30\text{ Nm}$  for ZSI fed IM

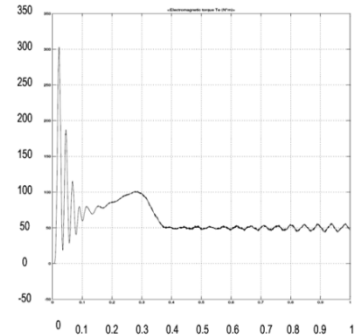

Figure 63. Torque at overload  $T=50\text{ Nm}$  for ZSI fed IM

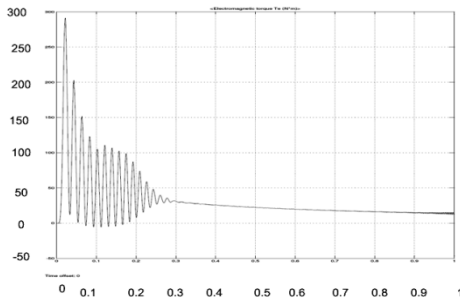

Figure 64. Torque at Overload  $T=100\text{ Nm}$  for ZSI fed IM

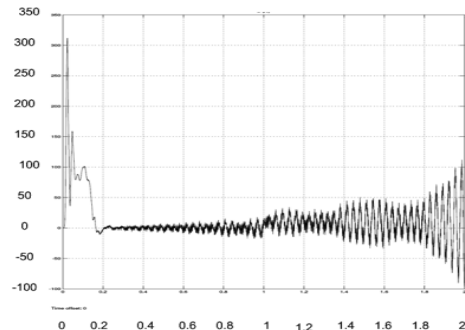

Figure 65. Torque under Step Load Torque 0 to 10 Nm at  $t= 1\text{sec}$  for ZSI fed IM

Electromagnetic torque ( $T_e$ ) tracks the load torque ( $T_L$ ) and ripple of the electromagnetic torque is small [20]. It is also noted that with the ZSI scheme motor attain the load torque with less time as compared to VSI.

## 6. CONCLUSIONS

This paper presents a comparative study on performance of the VSI, CSI and Z-Source Inverter (ZSI) based fed induction motor drive using simulink. The performance parameters of 3-phase induction motor such as rotor current, stator current, rotor speed, and electromagnetic torque was investigated for the different load conditions. It is evident that the proposed scheme of three-phase induction motor drive with Z-source and PWM technique is fast enough, reduces inrush current and harmonic current and leads to a satisfactory operation in open loop systems as compared to induction motor drive with VSI. Thus, it can be said that three phase inverter based on impedance (z)-source network with its boosting capability suitably controls and regulates the IM variable voltage and load variations.

## REFERENCES

- [1] Atul Kushwaha, Mohd Arif Khan, Atif Iqbal, Zakir Husain. Z- Source Inverter Simulation and Harmonic Study. *Global Journal of Advanced Engineering Technologies*. 2012; 1(1).
- [2] Bindeshwar Singh, SP Singh, J Singh, Mohd Naim. Performance evaluation of three phase induction motor drive fed from z-source inverter. *International Journal on Computer Science and Engineering (IJCSE)*. 2011; 3(3).
- [3] Jaswant Singh. Transient Analysis of Z-Source Inverter Fed Three-Phase Induction Motor Drive by Using PWM Technique. *International Electrical Engineering Journal (IEEJ)*. 2013; 4(1): 856-863.
- [4] Fang Zheng Peng, Alan Joseph, Miaosen Shen. Z source inverter for motor drives. *IEEE transactions on power electronics*. 2005; 20(4).
- [5] D Amudhavall, L Narendran. Improved Z Source Inverter for Speed Control of an Induction Motor. *International Journal of Advanced Research in Electrical, Electronics and Instrumentation Engineering*. 2013; 2(4).

- [6] Sweeka Meshram, Ganga Agnihotri, Sushma Gupta. An Efficient Z-Source Inverter based Solar Power Generation System Fed IM. *International Journal of Scientific & Engineering Research*. 2013; 4(1).
- [7] P Elangovan, C Kumar, V Suresh. Space Vector Modulation based Speed Control of Induction Motor Fed by Z-Source Inverter using PI controller. *The International Journal of Engineering And Science (IJES)*. 2013; 2(2): 130-137.
- [8] Fang Zheng Peng. Senior Member. IEEE Z-Source Inverter, IEEE transactions on industry applications. 2003; 39(2).
- [9] Omar Ellabban, Joeri Van Mierlo, Philippe Lataire. Experimental Study of the Shoot-Through Boost Control Methods for the Z-Source Inverter. *EPE Journal*. 2011; 21(2).
- [10] Santosh Sonar, Tanmoy Maity. A Single phase to Three Phase Buck-Boost Converter cum Voltage Regulator suitable for Wind Power. *Energy and Power*. 2012; 2(3): 33-38 doi: 10.5923/j.ep.20120203.02
- [11] S Nagaraja Rao, BM Manjunatha, VV Ramana Reddy. Shoot Through PWM control Strategies for three Level Z source Inverter. *International Journal of Systems, Algorithms & Applications*. 2012; 2(ICRAET12).
- [12] CS Sharma, Tali Nagwani. Simulation and Analysis of PWM Inverter Fed Induction Motor Drive. *International Journal of Science, Engineering and Technology Research (IJSETR)*. 2013; 2(2).
- [13] Aadyasha Patel1, A Mirunalini. Renewable Energy using Z-Source for High Power Applications. *IJREAT International Journal of Research in Engineering & Advanced Technology*. 2013; 1(1).
- [14] Ibrahim K Al-Abbas. Reduced Order Models of a Current Source Inverter Induction Motor Drive. *American J. of Engineering and Applied Sciences*. 2009; 2(1): 39-43.
- [15] Nisha kcr, TN Basavaraj. Implementation of impedance source inverter system for photovoltaic applications. *International Journal of Power System Operation and Energy Management ISSN (PRINT)*: 2(1): 2231-4407.
- [16] A Shanmuga priyaa, Dr R. Seyezhai, Dr BL Mathur. Performance Analysis of Cascaded Z-Source Multilevel Inverter using Third Harmonic Injection PWM. *International Journal of Computer Technology and Electronics Engineering (IJCTEE)*. 2(1).
- [17] SS Darly, P Vanaja Ranjan, B Justus Rabi, Bindu KV. Fault Tolerant Control in Z-Source Inverter Fed Induction Motor. *International Journal of Power Electronics and Drive System (IJPEDS)*. 2011; 1(1): 29-35.
- [18] Vijayabalan R, S Ravivarman. Z Source Inverter for Photovoltaic System with Fuzzy Logic Controller. *International Journal of Power Electronics and Drive System (IJPEDS)*. 2012; 2(4): 371-379.
- [19] Cong-Thanh Pham, An Wen Shen, Phan Quoc Dzung, Nguyen Bao Anh, Le Hoang Viet. Self-Tuning Fuzzy PI-Type Controller in Z-Source Inverter for Hybrid Electric Vehicles. *International Journal of Power Electronics and Drive System (IJPEDS)*. 2012; 2(4): 353-363.
- [20] Cong-Thanh Pham, An Wen Shen. A Comparative Control Method for Induction Motor and High Performance Z-source Inverter. *TELKOMNIKA*. 2013; 11(6): 2912-2925.

## BIOGRAPHIES OF AUTHORS



**Deepak Kumar** received the B.E from C.R State College of Engineering, Murthal (Sonapat) and M.Tech from National Institute of Technology, Kurukshetra. He is currently working as Lecturer in NIT Hamirpur. His main areas of interest are Power Electronics and drives, Renewable Energy Resources.  
Email: dkaroraelectrical@gmail.com, timothyarora@gmail.com



**Zakir Husain** took his Bachelor and Master degrees in Electrical Engineering from Aligarh Muslim University, Aligarh, India. Subsequently he did his Ph.D from Motilal Nehru National Institute of Technology, Allahabad, India. He has been employed as Lecturer in Department of Electrical Engineering, National Institute of Technology, Hamirpur (H.P.), India since 1989 and he is working as Associate Professor in the same institute. During 2011 and 20012 he was on Academic pursuit and worked as Head, Department of Electrical Engineering, College of Engineering, Salman Bin Abdulaziz University, Kingdom of Saudi Arabia. His principal research interests are Multi Phase Power Systems, Electric Drives, Condition Monitoring of Electric Devices and Renewable Energy Resources.  
Email: zahusain2@yahoo.com, zahusain2@gmail.com.