

Power Control of Wind Turbine Based on Fuzzy Sliding-Mode Control

Tahir Khalfallah*, Belfedal Cheikh*, Allaoui Tayeb*, Gerard Champenois**

*Laboratoire de Génie Energétique et Génie Informatique LGEGI, Université Ibn Khaldoun de Tiaret, Algérie

**University of Poitiers, Laboratoire d'Informatique et d'Automatique pour les Systèmes, Bâtiment B25, 2, rue Pierre Brousse, 86022 Poitiers, France

Article Info

Article history:

Received Oct 1, 2014

Revised Dec 14, 2014

Accepted Jan 5, 2015

Keyword:

Fuzzy sliding mode control
Maximum power point tracking
Wind energy conversion system
Wound field synchronous generator

ABSTRACT

This paper presents the study of a variable speed wind energy conversion system (WECS) using a Wound Field Synchronous Generator (WFSG) based on a Fuzzy sliding mode control (FSMC) applied to achieve control of active and reactive powers exchanged between the stator of the WFSG and the grid to ensure a Maximum Power Point Tracking (MPPT) of a wind energy conversion system. However the principal drawback of the sliding mode, is the chattering effect which characterized by torque ripple, this phenomena is undesirable and harmful for the machines, it generates noises and additional forces of torsion on the machine shaft. A direct fuzzy logic controller is designed and the sliding mode controller is added to compensate the fuzzy approximation errors. The simulation results clearly indicate the effectiveness and validity of the proposed method, in terms of convergence, time and precision.

Copyright © 2015 Institute of Advanced Engineering and Science.
All rights reserved.

Corresponding Author:

Tahir Khalfallah,
Departement of Electrical and Computer Engineering,
University Ibn Khaldun Tiaret, Algeria,
Email: tahir.commande@gmail.com

1. INTRODUCTION

Wind energy is becoming one of the most important renewable energy sources [1]. Recently, power converter control has mostly been studied and developed for WECS integration in the electrical grid.

In recent years, variable speed WECSs have become the industry standard because of their advantages over fixed speed ones such as improved energy capture, better power quality. They are capable of extracting optimal energy capture in addition to having reduced mechanical stress and aerodynamic noise. [2].

In terms of the generators for WECS, several types of electric generators are used such as Squirrel-Cage Induction Generator (SCIG), Synchronous Generator with external field excitation, Doubly Fed Induction Generator (DFIG) and Permanent Magnet Synchronous Generator (PMSG) with power electronic converter system [3]. Therefore, the study of synchronous generator has regained importance. The primary advantages of Wound Field Synchronous Generator are: The efficiency of this machine is usually high, because it employs the whole stator current for the electromagnetic torque production. The main benefit of the employment of wound field synchronous generator with salient pole is that it allows the direct control of the power factor of the machine, consequently the stator current may be minimized any operation circumstances [4].

The Sliding Mode Controller (SMC) is a particular type of variable structure control systems that is designed as a robust control to drive and then constrain the system to lie within of the switching function. However in the presence of large uncertainties or higher switching gain is required which produce higher amplitude of chattering.

Fuzzy logic has emerged as a powerful in control applications. It allows one to design a controller using linguistic rules without knowing the mathematical model of the plant.

In this paper our objective is to apply a fuzzy controller combined with sliding mode to overcome shattering of both sliding mode and fuzzy logic controllers and then to obtain a control system for a high performance for power system [5]. Simulation results are provided to show the effectiveness of the proposed overall WFSG control system.

2. WIND CONVERSION SYSTEM MODEL

The WECS described in this article includes the wind turbine, gearbox, WFSG, and back-to-back converters. The rotor winding of the WFSG is connected to the grid by DC/AC converter, whereas the stator winding is fed by back-to-back bidirectional PWM-VSC. In this system, the wind energy is transmitted through the turbine to the three-phase WFSG and generated in electrical form. This energy is transmitted directly through a bridge rectifier and inverter to the electrical network (Figure 1). We consider in this study that the rectifier is perfect. So semiconductors are ideal [6]. In this paper our study is limited to the generation of power in continuous form.

Figure 1 shows the equivalent diagram of the electrical portion of the string conversion of wind energy.

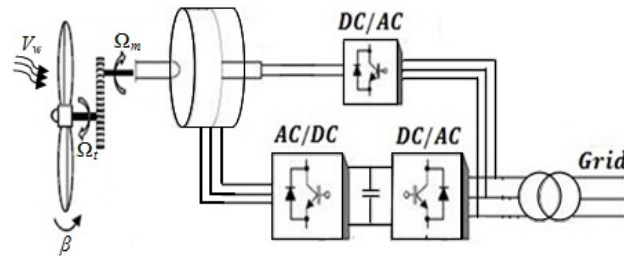

Figure 1. WFSG based wind energy conversion system

2.1. Modeling of the Wind Turbine and Gearbox

The turbine power and torque developed are given by the following relation [7]:

$$P_a = \frac{1}{2} \rho \pi R^2 V_w^3 C_p(\lambda, \beta) \quad (1)$$

$$T_a = \frac{P_a}{\Omega_r} = \frac{1}{2\lambda} \rho \pi R^3 V_w^2 C_p(\lambda, \beta) \quad (2)$$

Which λ presents the ratio between the turbine angular speed and the wind speed. This ratio called the tip speed ration and is defined as:

$$\lambda = \frac{\Omega_r R}{V_w} \quad (3)$$

Where ρ is the air density, R is the blade length, V_w is the wind speed, C_p is the power coefficient, Ω_r is the turbine angular speed.

The power coefficient (C_p) presents the aerodynamic efficiency of the turbine and depends on the specific speed λ and the angle of the blades. It is different from a turbine to another, and is usually provided by the manufacturer and can be used to define a mathematical approximation.

The wind turbine shaft is connected to the WFSG rotor through a gearbox which adapts the slow speed of the turbine to the WFSG speed. This gearbox is modeled by the following equations [8]:

$$\Omega_t = \frac{\Omega_m}{G}; T_m = \frac{T_a}{G} \quad (4)$$

From the dynamics fundamental relation, the turbine speed is determined as follows:

$$J \frac{d\Omega_m}{dt} = T_m - T_{em} - f\Omega_m \quad (5)$$

J and f are the total moment of inertia and the viscous friction coefficient appearing at the generator side, T_m is the gearbox torque, T_{em} is the generator torque, and Ω_m is the mechanical generator speed.

Figure 2 represents the power coefficient C_p as a function of β and λ .

Figure 3 shows the mechanical power as a function of rotor speed of the turbine for different values of wind speed [9].

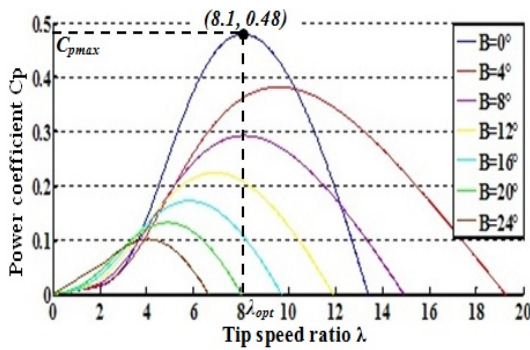

Figure 2. Power coefficient versus tip speed ratio

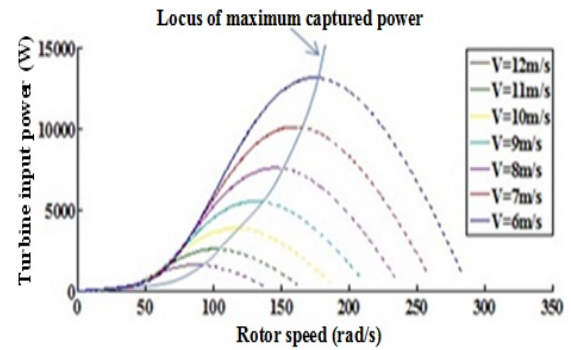

Figure 3. Rotor power versus rotational speed of generator

2.2. Modeling of the WFSG

In the synchronous d-q coordinates, the voltage equation of the WFSG is expressed as follows [10]:

$$v_{ds} = -r_s i_{ds} + \omega_e L_q i_{qs} - \omega_e m_{sQ} i_Q - L_d \frac{di_{ds}}{dt} + m_{sf} \frac{di_f}{dt} + m_{sD} \frac{di_D}{dt} \quad (6)$$

$$v_{qs} = -r_s i_{qs} - \omega_e L_d i_{ds} + \omega_e m_{sf} i_f + \omega_e m_{sD} i_D - L_q \frac{di_{qs}}{dt} + m_{sQ} \frac{di_Q}{dt} \quad (7)$$

$$\begin{cases} 0 = r_D i_D + \frac{d}{dt} \varphi_D \\ 0 = r_Q i_Q + \frac{d}{dt} \varphi_Q \end{cases} \begin{cases} \varphi_D = L_D i_D + m_{fD} i_f - m_{sD} i_{ds} \\ \varphi_Q = L_Q i_Q - m_{sQ} i_{qs} \end{cases} \quad (8)$$

Where:

L_D, L_Q : inductances of the direct and quadrature damper windings.

L_f : inductance of the main field winding.

L_d, L_q : inductances of the d-axis stator winding and q-axis stator winding.

m_{sf} : mutual inductance between the field winding and the d-axis stator winding.

m_{sD} : mutual inductance between the d-axis stator winding and the d-axis damper winding.

m_{sQ} : mutual inductance between the q-axis stator winding and the q-axis damper winding.

m_{fD} : mutual inductance between the field winding and the d-axis damper winding.

ω_e : is the electrical angular speed, $\omega_e = p\Omega_m$

The electromagnetic torque is expressed by:

$$T_{em} = p(\varphi_d i_{qs} - \varphi_q i_{ds}). \quad (9)$$

3. SLIDING MODE CONTROL

To achieve the maximum power at below rated wind speed, sliding mode based torque control is proposed in [11]. The main objective of this controller is to track the reference rotor speed Ω_{m_ref} for maximum power extraction. In conventional sliding mode control, sliding surface generally depends on error, and derivative of the error signal is given in (10).

$$\sigma(x) = \left(\lambda_x + \frac{d}{dt} \right)^{n+1} (x_{ref} - x) \quad (10)$$

Where λ is the positive constant and n is the order of the uncontrolled system.

The speed error is defined by [12]:

$$e_{\Omega_m} = \Omega_{m_ref} - \Omega_m. \quad (11)$$

For $n = 1$, the position control manifold equation can be obtained from Equation (10) as follow:

$$\sigma(\Omega_m) = \Omega_{m_ref} - \Omega_m. \quad (12)$$

The derivative of this surface is given by the expression:

$$\dot{\sigma}(\Omega) = c_2 \Omega_m - c_1 + \dot{\Omega}_{m_ref} + c_3 (m_{sf} i_f + m_{sD} i_D) i_{qs}. \quad (13)$$

During the sliding mode and in permanent regime, we have:

$$\sigma(\Omega_m) = 0, \dot{\sigma}(\Omega_m) = 0, i_{qs}^n = 0. \quad (14)$$

The current control i_{qs} is defined by:

$$i_{qs} = i_{qs}^{eq} - i_{qs}^n. \quad (15)$$

The control voltage i_{qs_ref} is defined by:

$$i_{qs_ref} = \frac{-c_2 \Omega_m + c_1 - \Omega_{m_ref}}{c_3 (m_{sf} i_f + m_{sD} i_D)} + k_{\Omega_m} \text{sat}(\sigma(\Omega_m)) \quad (16)$$

The stator currents i_{qs} and i_{ds} are the images, respectively, of the P_s and the Q_s , which must follow their references.

3.1. Quadratic Rotor Current Control with SMC

The sliding surface representing the error between the measured and reference quadratic rotor current is given by:

$$\sigma(i_{qs}) = e_{i_{qs}} = i_{qs_ref} - i_{qs} \quad (17)$$

$$\dot{\sigma}(i_{qs}) = \dot{i}_{qs_ref} - \dot{i}_{qs} \quad (18)$$

Substituting the expression of \dot{i}_{qs} Equation (7) in Equation (18), Equation (19) and Equation (20) can be obtained.

$$\dot{\sigma}(i_{qs}) = \dot{i}_{qs_ref} + \frac{1}{L_q} (r_s i_{qs} + a_1 i_{ds} - a_2 i_f - a_3 i_D - m_{sQ} \dot{i}_Q + v_{qs}) \quad (19)$$

And,

$$v_{qs} = v_{qs}^{eq} - v_{qs}^n \quad (20)$$

During the sliding mode and in permanent regime, there is:

$$\sigma(i_{qs}) = 0, \dot{\sigma}(i_{qs}) = 0, v_q^n = 0 \quad (21)$$

Where the equivalent control is:

$$v_{qs}^{eq} = -L_q \dot{i}_{qs_ref} - r_s i_{qs} - a_1 i_{ds} + a_2 i_f + a_3 i_D + m_{sQ} \dot{i}_Q \quad (22)$$

Therefore, the correction factor is given by:

$$v_{qs}^n = K_{v_q} \text{sat}(\sigma(i_{qs})) \quad (23)$$

Where K_{v_q} is positive constant.

3.2. Direct Rotor Current Control with SMC

The sliding surface representing the error between the measured and reference direct rotor current is given by:

$$\sigma(i_{ds}) = e_{i_{ds}} = i_{ds_ref} - i_{ds} \quad (24)$$

$$\dot{\sigma}(i_{ds}) = \dot{i}_{ds_ref} - \dot{i}_{ds} \quad (25)$$

Substituting the expression of \dot{i}_{ds} Equation (6) in Equation (25), there is:

$$\dot{\sigma}(i_{ds}) = \dot{i}_{ds_ref} + \frac{1}{L_d} (r_s i_{ds} - b_1 i_{qs} + b_2 i_Q - m_{sf} \dot{i}_f - m_{sD} \dot{i}_D + v_{ds}) \quad (26)$$

And,

$$v_{ds} = v_{ds}^{eq} - v_{ds}^n \quad (27)$$

During the sliding mode and in permanent regime, Equation (28) can be obtained.

$$\sigma(i_{ds}) = 0, \dot{\sigma}(i_{ds}) = 0, v_{ds}^n = 0 \quad (28)$$

Where the equivalent control is:

$$v_{ds}^{eq} = -L_d \dot{i}_{ds_ref} - r_s i_{ds} + b_1 i_{qs} - b_2 i_Q + m_{sf} \dot{i}_f + m_{sD} \dot{i}_D \quad (29)$$

Therefore, the correction factor is given by:

$$v_{ds}^n = K_{v_d} \text{sat}(\sigma(i_{ds})) \quad (30)$$

Where K_{v_d} is positive constant.

$$a_2 = m_{sf} \omega_e; \quad b_2 = m_{sQ} \omega_e; \quad c_2 = \frac{f}{J}; \quad c_3 = \frac{p}{J}; \quad a_1 = L_d \omega_e; \quad b_1 = L_q \omega_e; \quad a_3 = m_{sD} \omega_e;$$

$$c_1 = \frac{T_m}{J}$$

4. FUZZY LOGIC CONTROLLER

Fuzzy-logic control has the capability to control nonlinear, uncertain and adaptive systems with parameter variation. Fuzzy control does not strictly need any mathematical model of the plant. Its control rule can be qualitatively expressed on the basis of logic-language variation and the fuzzy model of a plant is very easy to apply. In fact, fuzzy control is good adaptive control among the techniques discussed so far. In this paper, fuzzy-logic control is associated with sliding-mode control to generate the switching controller term $K\text{sat}(\sigma(i_{dqs}))$, which ensures the precision and robustness of the control [12].

The general structure of a fuzzy-control system is shown in Figure 4. There are two input signals to the fuzzy controller, the error E and the change in error CE , which is related to the derivative DE/dt of error. The closed-loop error E and change in error CE signals are converted to the respective scale factors, $e = E/GE$ and $ce = CE/GC$. The output plant control signal DU is derived by multiplying by the scale factor GU , that is $DU = du * GU$, and then integrated to generate the U signal [13].

The scale factors can change the sensitivity of the controller without changing its structure. The fuzzy controller is composed of three blocks: fuzzification, rule bases, and defuzzification. The membership functions for inputs output variables are shown in Figure 5. The fuzzy subsets are as follows: GN (Grand negative), N (Negative), ZR (Zero), P (Positive), and GP (Grand positive). There are seven fuzzy subsets for each variable, which gives $5 \times 5 = 25$ possible rules. The fuzzy rules that produce these control actions are reported in Table 1.

The Defuzzification of the output control is accomplished using the method of center of gravity. When the error is below zero, the universe of the control value should be expanded by a contraction-expansion factor $F(x)$. When the error is above zero, the universe should be contracted. Therefore $F(x)$ is defined as $F(x) = M \cdot x^{1/M}$ (M gain positive).

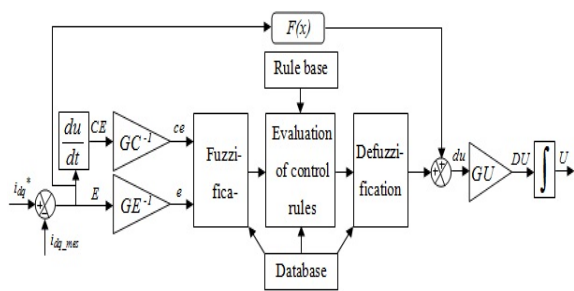

Figure 4. Structure of the fuzzy controller

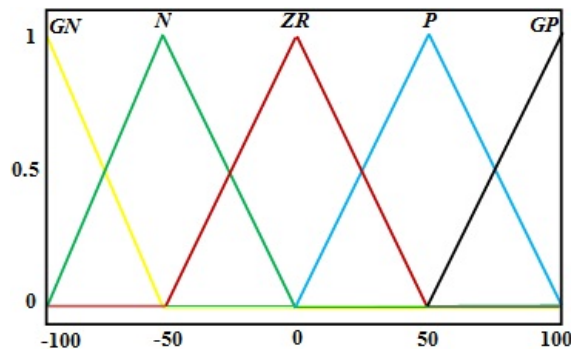

Figure 5. Membership functions of e , ce and DU

Table 1. Rules base

	GN	N	ZR	P	GP
GN	GN	GN	GN	N	ZR
N	GN	N	N	ZR	P
ZR	N	N	ZR	P	P
P	N	ZR	P	P	GP
GP	ZR	P	GP	GP	GP

5. SIMULATION RESULTS AND DISCUSSION

To demonstrate the pertinence of the proposed WFSG Fuzzy-sliding-control approach (Figure 6), simulation has been performed for 7.5KW WFSG wind power system using Matlab/Simulink™. The wind profile used in our simulations is shown in Figure 7(a).

In addition, aerodynamic power is optimized with MPPT strategy and keeps at his nominal value when the wind speed exceeds the nominal value as shows in Figure 7(b), and the power coefficient C_p is the maximum around 0.48 as shown in Figure 7(c).

By applying the proposed control scheme, the optimal speed command is accurately tracked to extract the maximum power from the wind energy at any moment. In Figure 7(d) the generated torque reference follows the optimum mechanical torque of the turbine quite well. Figure 7(e) shows the speed tracking results of the WFSG. In terms of the actual wind speed, the optimal WFSG speed command is obtained by Eq. (3).

The decoupling effect of the between the direct and quadratic stator current of the WFSG is illustrated in Figure 7(f).

The stator current and voltage waveforms and these zoom of the WFSG are presented in Figure 7(g). As shown in this Figures, the stator currents are proportional to the wind speed. This is due to the reason that when the wind speed increases (not larger than 9.1 m/s), there is more power generated, thus yield more currents in the stator windings of the WFSG.

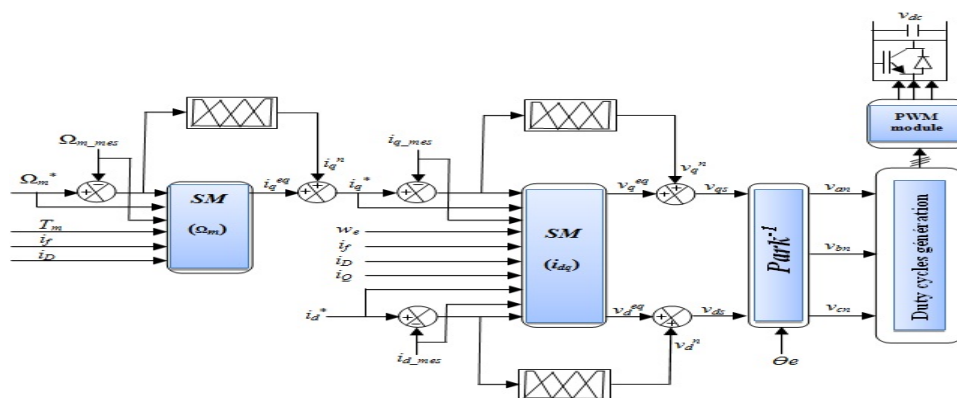

Figure 6. Global diagram of simulation and control of WFSG with Fuzzy-SMC

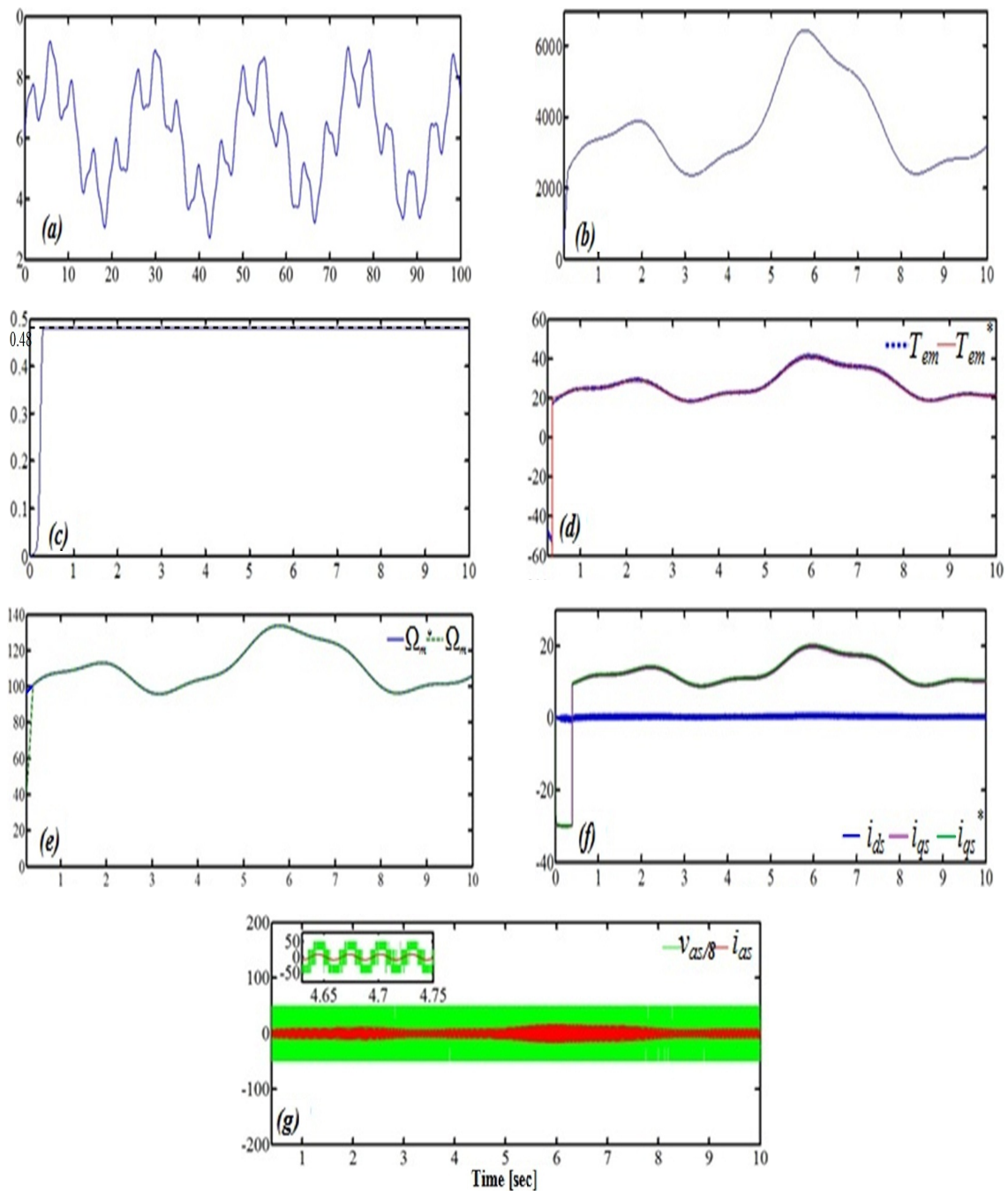

Figure 7. System performance under wind speed variation. (a) Wind speed [m/s]. (b) Aerodynamic power [W]. (c) Power coefficient. (d) Generated torque [N.m]. (e) Generator speed [rad/s]. (f) Direct and quadratic stator current [A]. (g) Stator current and voltage with zoom [A, V]

6. CONCLUSION

In this paper, a fuzzy sliding mode controller is applied to control the power generated by the WECS based on wound field synchronous generator and to realize nonlinear control. We have established a model of the wind conversion chain, and design a control strategy based on vector control. This structure has been used for reference tracking of active and reactive powers exchanged between the stator and the grid by controlling the stator converter. A series of simulations are performed to test the effectiveness of this controller. The simulation results show that the proposed fuzzy-SMC is very good in dealing with the time-varying, nonlinear nature of WECS. The fuzzy-SMC was also proven more effective than the FLC and SM controller regarding the control performance and power capture.

ACKNOWLEDGEMENTS

The authors gratefully appreciate the support of Tiaret University, Algeria.

REFERENCES

- [1] Bouzid MA, Zine S, Allaoui T, Massoum A. Adaptive Fuzzy Logic Control of Wind Turbine Emulator. *International Journal of Power Electronics and Drive System (IJPEDS)*. 2014; 4(2); 233-240
- [2] Thongam JS, Bouchard P, Beguenane R, Okou AF. *Control of variable speed wind energy conversion system using a wind speed sensorless optimum speed MPPT control method.* 37th Annual Conference on IEEE Industrial Electronics Society (IECON). 2011; 7-10.
- [3] Blaabjerg F, Iov F, Chen Z, Ma K. *Power electronics and controls for wind turbine systems.* IEEE International Energy Conference and Exhibition. 2010; 333-344 Dec.
- [4] E. Topal and L. Ergene, "designing a wind turbine with permanent magnet synchronous machine" *IU-JEEE* 2011.
- [5] Khaddouj BM, Faiza D, Ismail B. fuzzy sliding mode controller for power system SMIB. *Journal of Theoretical and Applied Information Technology*. 2013; 54 (2); 331-338.
- [6] Chunting Mi, Filippa M, Shen J, Natarajan N. Modeling and control of variable speed constant frequency synchronous generator with brushless exciter. *IEEE Transactions on Industry Applications*. 2004; 40(2); 565–73.
- [7] Camblong H. Minimizing the impact of wind turbine disturbances in the electricity generation by wind turbines with variable speed" (Minimisation de l'impact des perturbations d'origine éolienne dans la Génération d'électricité par des aérogénérateurs à vitesse variable). *PhD thesis; ENSAM; Bordeaux; 2003.*
- [8] Belabbas B, Tayeb A, Mohamed T, Ahmed S. Hybrid Fuzzy Sliding Mode Control of a DFIG Integrated into the Network. *International Journal of Power Electronics and Drive System (IJPEDS)*. 2013; 3(4); 351-364.
- [9] Refoufi L, Al Zahawi BAT, Jack AG. Analysis and modelling of the steady state behavior of the static Kramer induction generator. *IEEE Transaction Energy Conversion*. 1999; 14(3); 333–339.
- [10] Abdallah B, Slim T, Gérard C, Emile M. Analysis of synchronous machine modeling for simulation and industrial applications. *Simulation Modelling Practice and Theory*. 2010; 18(3); 1382–1396.
- [11] Merabet A, Beguenane R, Thongam JS, Hussein I. *Adaptive sliding mode speed control for wind turbine systems.* In: Proceedings of the 37th Annual Conf on IEEE Industrial Electronics Society. 2011; 2461– 2466.
- [12] Yongfeng Ren, Hanshan Li, Jie Zhou, Zhongquan An. *Dynamic Performance Analysis of Grid-connected DFIG Based on Fuzzy Logic Control.* International Conference on Mechatronics and Automation (ICMA). 2009; 719–723.
- [13] Zadeh LA. *Fuzzy setes, Information and Control.* 8 338–353. 1965.

BIOGRAPHIES OF AUTHORS



Tahir Khalfallah is PhD student in the Department of Electrical Engineering in at the Dr Moulay Tahar University of Saida, ALGERIA. He received a MASTER degree in Actuator and industrial control from the UDMT of Saida. His research activities include the Renewable Energies and the Control of Electrical Systems. He is a member in Energetic Engineering and Computer Engineering Laboratory (L2GEGI).



Belfedal Cheikh received the Magister degree in electrical engineering from Tiaret University, Algeria, in 1996. Currently he is with the Department of Electrical Engineering, Tiaret University. His fields of interest are control of electrical machines, power converters, modelling and control of wind turbines. He is a member in Energetic Engineering and Computer Engineering Laboratory (L2GEGI)



Allaoui Tayeb received his engineer degree in electrical engineering from the Ibn Khaldoun University of Tiaret in 1996 and his master degree from the University of Science and Technology of Oran in 2002. His research interests includes intelligent control of power systems and FACTS, Active filter and renewable energies. He is a Director of Energetic Engineering and Computer Engineering Laboratory (L2GEGI).



Gerard Champenois (M'09) was born in France in 1957. He received the Ph.D. and "Habilitation" degrees from the Institut National Polytechnique de Grenoble, Grenoble, France, in 1984 and 1992, respectively. He is currently a Professor with the Automatic Control and Industrial Data Processing Laboratory (LAI), Poitiers National School of Engineering (ESIP), University of Poitiers, Poitiers, France. His major fields of interest in research are renewable energy systems, energy storage systems, electrical machines associated with static converter, control, modeling, and diagnosis.