

# Defining Control Strategies for Micro Grids Islanded Operation with Maximum Power Point Tracking using a Fuzzy Logic Control Scheme

B V Rajanna<sup>1</sup>, Ganta Joga Rao<sup>2</sup>, S.K Shrivastava<sup>3</sup>

<sup>1</sup> Department of Electrical and Electronics Engineering, KL University, India

<sup>2,3</sup> Department of Electrical and Electronics Engineering, SunRise University, India

---

## Article Info

### Article history:

Received Nov 12, 2015

Revised Mar 15, 2016

Accepted Apr 16, 2016

---

### Keyword:

Distributed generation

Islanded operation

MATLAB/Simulink

Micro-Grids

MPPT

PV system

---

## ABSTRACT

This paper explains about an intelligent control method for the maximum power point tracking (MPPT) of a photo voltaic system with different temperature and insolation conditions. This method uses a fuzzy logic controller applied to a DC-DC converter. The different steps of the design of this controller are presented together with its simulation and the feasibility of control methods to be adopted for the operation of a micro grid when it becomes isolated. Normally, the micro grid operates in interconnected mode with the medium voltage network; however, scheduled or forced isolation can take place. In such conditions, the micro grid must have the ability to operate stably and autonomously. An evaluation of the need of storage devices and load to take off strategies is included in this paper. The MPPT of a photovoltaic system for Micro Grid operation using a Fuzzy logic control scheme is successfully designed and simulated by using MATLAB/Simulink Software.

Copyright © 2016 Institute of Advanced Engineering and Science.  
All rights reserved.

---

## Corresponding Author:

B V Rajanna,  
Department of Electrical and Electronics Engineering,  
KL University, Green Fields, Vaddeswaram,  
Pincode: 522502, Guntur District, A.P., India.  
Email: bv.rajanna@gmail.com

---

## 1. INTRODUCTION

Micro generation is expected to become an attractive mean to face the continuous demand growth in the electric power systems. On the other hand, the need of reducing pollutant emissions, recent technological developments related with the improvement of micro generation efficiency and the possibility of exploiting local renewable energy resources are important factors that will contribute, in a short term, to an effective penetration of micro generation in LV grids.

The method of an extensive penetration of local generation in LV grids leads to the definition of the Micro Grids (MG) concept [1] and [13]. Small generation units are the micro sources (MS) with power ratings less than a few tens of kilowatts may increase reliability to the final consumers and will bring additional benefits for global system operation and planning. A MG compromise a LV network (for example covering an urban area, a shopping-center or even an industrial park), these loads are several small modular generation systems connected to it and an embedded control and management system [2]. This concept used to study with in the structure of an EU R&D project to study the problems challenging the integration of large amounts of different type of MS in LV grids and involves several institutions and companies. Examples of MS technologies to be used when building MG include renewable power sources, such as wind and photo voltaic (PV) generators [1], micro turbines works on gas or bio-fuels, different types of fuel-cells, and also storage devices (such as flywheels or batteries).

**General Overview.**The first approach relates to the working of the MG control modes regarding the usual schemes to control a power electronic device. As there is not expectable to have fully controllable synchronous generators in a MG, converters are responsible for voltage and frequency control during islanded operation [3]. The usual control approaches control an inverter can be defined as [4]:

1. PQ control-the inverter is operated to inject a given active and reactive power [18].
2. Voltage Source Inverter (VSI) Control-the VSI acts as a voltage source with controlled magnitude and frequency.

The VSI is to be coupled with a storage device and to equal load and generation during islanded operation. Its control is preformed using droop concepts [5-7]. On important feature of the VSI is its capability to react to power systems disturbances during isolated operation based only on data available at its terminals [5]. In this way, a seamless transition between interconnected and independent operation mode can occurs, since it is supported by the VSI in the first moments.

The practicality of the MG islanding mode concept was laboratory tested in a prototype installed in the National Technical University of Athens (NTUA), which compromises a photo voltaic (PV) generator, battery energy storage, loads, and a controlled inter-connection into an LV grid. The converters used to couple the PV and the battery storage to the LV grid allow MG operation either in an LV grid inter-connected mode or under islanded conditions [19]. Also, experimental tests for islanding and synchronization were presented in [9]. The work description in this paper regards the evaluation, through numerical simulation, of the inverter-fed MG dynamic behavior under the islanded operation for different load conditions and using two different control strategies. The impact of the considering primary energy source dynamics and the inverters contributions to faults are issues addressed in this paper [3]. The ability of the tested control strategies were evaluated for large disturbances taking place in the MV network, followed by a forced islanding mode of the MG. Since there is little inertia in the MG, and MS have small time constants, a combination of load shedding strategies and the use of storage devices were investigated in order to avoid large frequency and voltage fluctuations during the operating emergency mode conditions [19].

## 2. PROPOSED METHOD

### 2.1. MG Architecture

Figure 1 shows a typical MG structure, which comprises a LV network, loads or equivalent groups of loads (assumed to be controlled or interruptible), both controlled and uncontrolled MS, storage devices and a hierarchical-type management and control scheme supported by the communication system used to fulfill the potential of dispersed generation aiming at an economical management and optimal technical. The MG is centrally controlled and managed by the Micro-Grid Central Controller (MGCC), which is installation at the LV side of a MV/LV substation. The MGCC possesses several management functions are both technical and economical, in order to fully profit from the dispersed generation resources [21]. A second hierarchical control level is established at the MS and loads level: MS are locally controlled by a Micro-source Controller (MC) and group of loads or electrical loads are controlled by a Load Controller (LC). A communication infrastructure must be provided in order to guarantee information exchange between the MGCC and the other controllers. The communication system among the described controllers is as follows:

1. LC is interfacing to control loads through the application of an interruption concept.
2. MC controls locally the MS active and reactive powers production levels.
3. The MGCC, as central controller, promotes adequate technical and economical management policies are provides set-points to LC and MC; it is also responsible for the local BS functionalities.

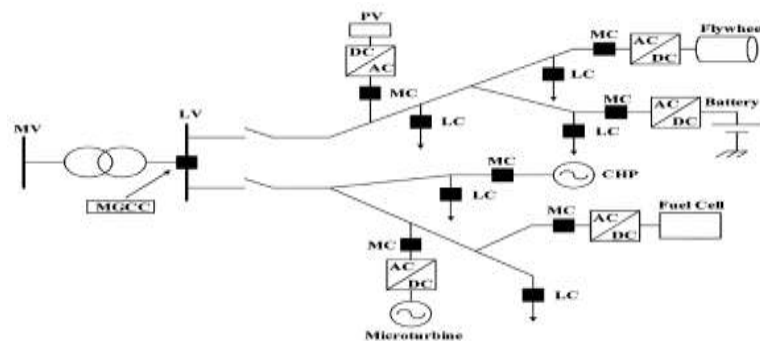

Figure 1. MG architecture, comprising MS, loads, and control devices

The amount of data to be exchanged between network controllers is small, since it includes mainly messages containing set-points to LC and MC, information suggestions sent by the MGCC to LC and MC about active and reactive powers, voltage levels and messages to control MG switches. Also, the short geographical span of the MG may aid establishing a communication infrastructure using low-cost communications.

## 2.2. Dynamic Modelling of Components

MS dynamic models are used in the simulation platforms are briefly described in this section. The characteristics of the electric energy produced in some MS (high frequency AC power in single shaft micro-turbines or DC power in PV and fuel cells) are requires the presence of power electronic stages (AC-DC-AC or DC-AC), whose modelling is also presented [14].

### 2.2.1. Micro Source Modeling

Several MS models are able to describe their dynamic behavior, have been developed from available literature, which include PV arrays wind turbines, fuel-cells, and micro-turbines [16].

A detailed description of the models adopted for single shaft micro-turbines (SSMT) and solid oxide fuel cells (SOFC) can be found in [4] and [6]. A small asynchronous wind turbine (constant speed) directly connected to the LV grid was also included in the simulation platform. Details of the MPPT control system were not added in the PV model. Instead, it was assumed that the array is always working at its maximum power level for a given irradiance and temperature as described in [5-6]. Storage devices like flywheels and batteries are modelled as constant DC sources (taking into account the time span under analysis).

The GAST dynamic model [11] was adopted for the primary unit of micro-turbines, since these units are small simple-cycle gas turbines. Both split-shaft units (using a power turbine rotating at 3000 rpm and a conventional induction generator connected via a gearbox) and high-speed single-shaft units (with a synchronous machine) were modeled [17]. The single-shaft micro turbine (SSMT) requires an ac/dc/ac converter for grid interconnection.

A wind generator was also included in the library of MS using for that purpose an IG directly connected to the network and represented by a fifth-order model, available in MATLAB Simulink toolboxes. Concerning the PV generator, it was assumed that the array is always working at its maximum power level for a given irradiance and temperature. Basically, it is an empirical model based on experimental results as described in [13], where a detailed MS modeling adopted in the MG project can also be found.

### 2.2.2. Inverter Modelling

As Micro generators are inverted networks, the uses of adequate control strategies in the solid state converters are crucial for Micro generators operation. These techniques are usually divided into 2 types [7]:

1. PQ inverter control: the inverter is operated to supply a given active and reactive power set-point.
2. Voltage Source Inverter control logic: the inverter is controlled to “feed” the load with predefined values for voltage and frequency. Depending on the load, the Voltage Source Inverter (VSI) active and reactive power output is defined [17].

When analyzing the long term dynamic behavior of the MG, inverters are modeled only by their control functions. This means that fast switching transients, harmonics and inverter losses are neglected.

#### 2.2.2.1. PQ Converter Control

The PQ controlled converter operates by injecting into the grid the power available at its input. The re-active power supplied corresponds to a pre-defined value, specified locally (using a local control loop) or centrally from the MGCC. The PQ inverter control system as shown in Figure 2.

#### 2.2.2.2 VSI Control

The VSI follows the behavior of a synchronous machine, thus controlling voltage and frequency on the ac system. The VSI acts as a voltage source, with the frequency and magnitude of the output voltage controlled through droops, as described in the following equations:

$$\begin{aligned}\omega &= \omega_0 - k_p * P \\ V &= V_0 - k_p * Q\end{aligned}\tag{1}$$

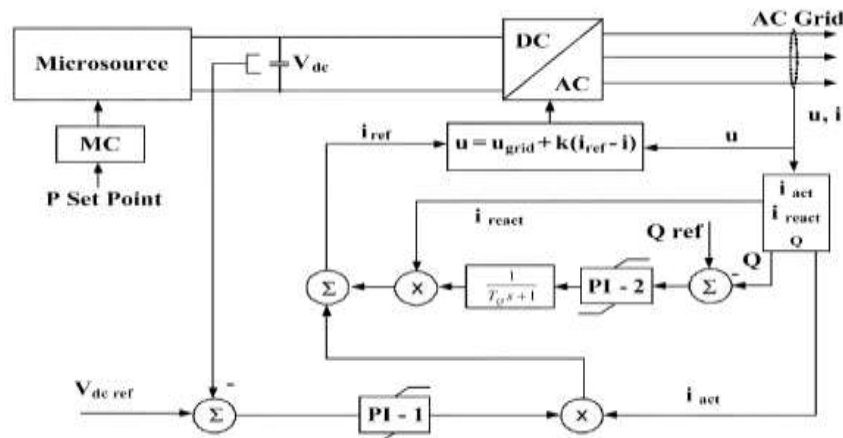

Figure 2. PQ inverter control system

### 2.2.2.3. Inverter Control during Overloads and Short Circuits

Inverter over currents can be caused by overloads or by short circuits. When changing to islanded operation or when a heavy load is connected during islanded operation, the initial high variance between local load and generation may lead to heavy frequency variations and transient overload of the VSI, since this unit has a fast response to this type of situations. In order to overcome this problem, the following two solutions were adopted.

- Permits a disconnection of less important loads (load shedding activated by under-frequency relays);
- Uprate the VSI, permitting an overload situation during a certain time interval (at least greater than the one required for load shedding activation).

### 2.2.3. Network and Load Modeling

In this paper, the evaluation of the feasibility of MG islanded operation was executed through the analysis of the LV network dynamic behavior considering only three-phase balanced operation, inspired by the fact that this is not the most common situation in LV distribution networks [10] and [23]. Two load types were considered: constant impedance loads (dependent on frequency and voltage) and motor loads (induction motor with nominal power ranging between 3 and 10 kW). Electrical parameters of motor loads are typical values available in MATLAB Simulink SimPowerSystems toolbox. As will be shown, load characteristics greatly influence the dynamic behavior of the MG, mainly under short-circuit conditions.

Controllable loads in the MG, available for load shedding purposes, have also been modeled. The amount of load to be shed is defined based on the amplitude of frequency deviation. In this study, motor loads have not been considered as settable loads.

## 3. RESEARCH METHOD

### 3.1. MG Control for Islanded Operation

In conventional power systems, synchronous generators are used for voltage and frequency control of the entire system. In a MG inverters should be responsible for controlling frequency and voltage during islanded operation. Otherwise the Micro generator could experience voltage and/or reactive power oscillations. Islanding of the Micro generator can take place by unplanned events like faults in the HV network or by planned actions like maintenance requirements. In this case, the local generation profile of the MG can be modified in order to reduce the imbalance between local load and generation and reduce the transient [6]. In the presence of unplanned events like faults, MG separation from the HV network must occur as fast as possible. However, the switching transient will have great impact on MG dynamics [12].

#### 3.1.1. Single Master Operation

A brief review of an SMO is shown in Figure 3. In this case, a VSI-acting as reference-can be used as voltage reference when the main power supply is lost being that all the other inverters operated in PQ mode (carrier). Local MS controllers can receive information from the MGCC about the generation profile and control accordingly the corresponding MS.

### 3.1.2. Multi Master Operation

As described in Figure 4, in a multi master approach, several inverters are operating as VSI with pre specified frequency/active power and voltage/reactive power characteristics. The VSI can be connected to storage devices (cells or flywheels) or to Main System with storage devices in the dc-link (batteries, super capacitors), which are charged by the primary energy source. Eventually, other PQ-controlled inverters may also coexist. The MGCC can modify the generation profile by changing the idle frequency of VSI and or by defining new set points for controllable Main system connected to the grid through PQ-controlled inverters [22].

The block diagram of LV test Network is as shown in Figure 5 above. The implementation of the LV test system under the MATLAB® Simulink® environment is shown in Figure 6. This is a modular simulation platform, where the control parameters and models can be easily included and modified using the “mask” functionalities provided by MATLAB® Simulink®. A similar platform was implemented under the *EMTP-RV*®. For this one, a very simple sinusoidal PWM control switching scheme for VSI inverters was implemented to analyse the fast transients associated with the initials moments of the BS procedure.

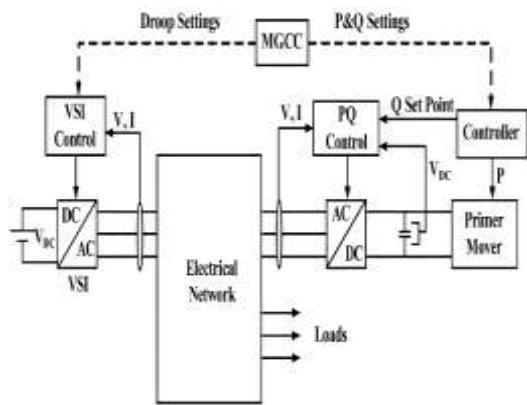

Figure 3. Control scheme for SMO

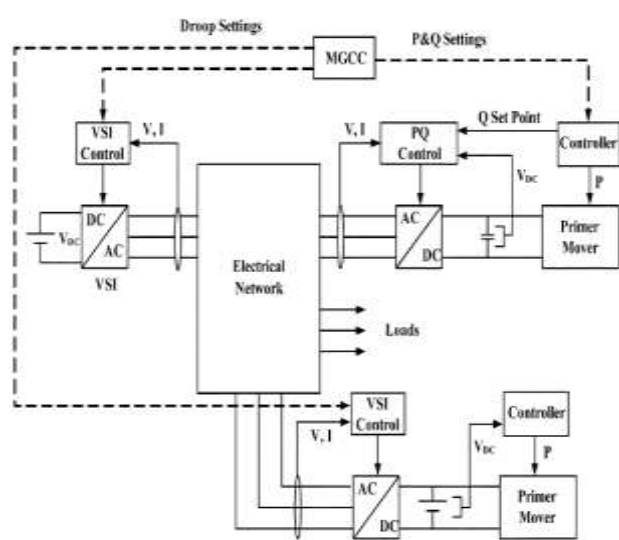

Figure 4. Control scheme for MMO

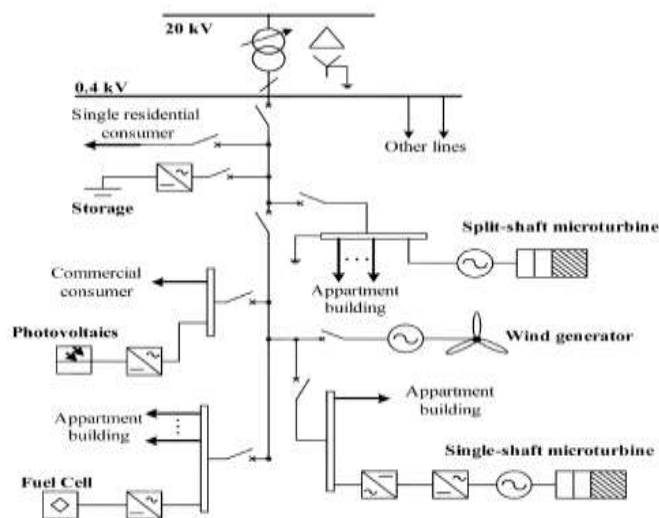

Figure 5. LV test Network

### 3.1.3. Fuzzy Logic Controllers

Prof. L.A. Zadeh implemented methodical treatment for Fuzzy Logic controller and later on Mamdani and Assilian used fuzzy sets with a reconciling feedback control method to control a small toy steam engine. This was the first practical applications of fuzzy logic controller (FLC). Mamdani applied FLC in the automatic control system of a rotary furnace for cement manufacturing after that and later on in the year 1980, Larsen used the fuzzy logic for various industrial applications. For development of FLC in industrial applications first Fuzzy International Conference was held in 1985 in Japan. Yamakawa designed a super high speed fuzzy controller for the Sendai underground railways, which was utilized by Hitachi Company in Japan. This system automatically decreased the speed of a train on entering a station, ensuring that the train stopped at a predetermined place. It also had the benefit of being a highly comfortable ride through mild acceleration and braking. Today, there is number of products in the market which are controlled by fuzzy logic [9] in which different types of FLC is used. In general this type of FLC contains four main parts, two of which perform transformations, which are:

- a. Fuzzifier (transformation 1)
- b. Knowledge base
- c. Inference engine
- d. Defuzzifier (transformation 2)

Fuzzification measures the values of input variable and converts input data into suitable linguistic values. Knowledge base consist a database and provides necessary definitions, which are used to define linguistic control rules. This rule base characterized the control goals and control policy of the domain experts by means of a set of linguistic control rules. Decision-making logic or inference mechanism is main part of a FLC. It has the capability of simulating human decision-making based on fuzzy concepts and of inferring fuzzy control actions employing fuzzy implication and the rules of inference in fuzzy logic. Defuzzification is a scale mapping, which converts the range of values of output variables into corresponding universe of discourse and also yields a non-fuzzy control action from an inferred fuzzy control action. This transformation is performed by Membership Functions (MF). In FLC, number of MF and their shapes are initially determined by user.

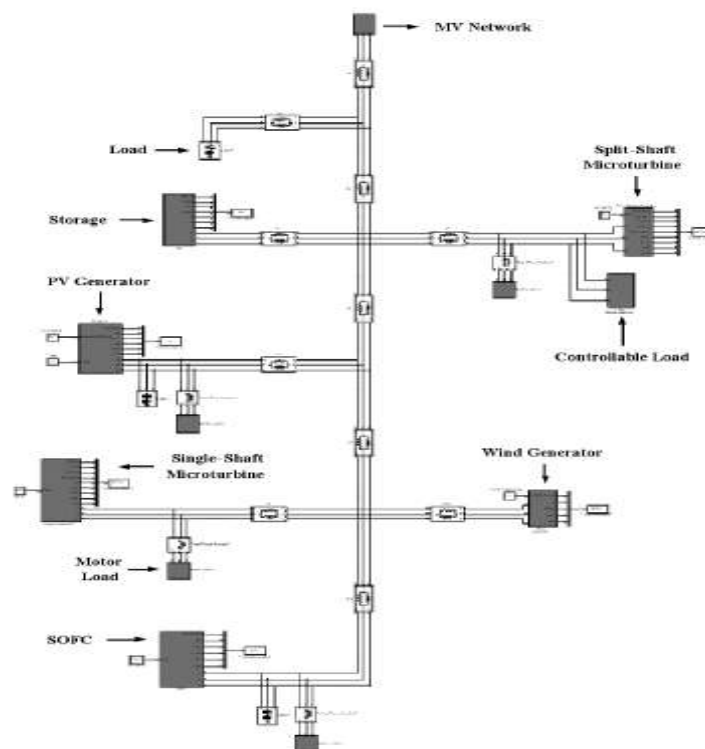

Figure 6. LV Network for the MATLAB Simulation

### 3.1.4. Fuzzy Logic MPPT Controller

Recently fuzzy logic controllers have been introduced in the tracking of the MPP in PV systems. They have the advantage to be robust and relatively simple to design as they do not require the knowledge of the exact model. They do require in the other hand the complete knowledge of the operation of the PV system by the designer.

The proposed FL MPPT Controller, shown in Figure 7, has two inputs and one output. The two FLC input variables are the error  $E$  and change of error  $CE$  at sampled times  $k$  defined by:

$$E(k) = \frac{P_{ph}(k) - P_{ph}(k-1)}{V_{ph}(k) - V_{ph}(k-1)}$$

$$CE(k) = E(k) - E(k-1) \quad (2)$$

where  $P_{ph}(k)$  is the instant power of the photovoltaic generator.

The input  $E(k)$  shows if the load operation point at the instant  $k$  is located on the left or on the right of the maximum power point on the PV characteristic, while the input  $CE(k)$  expresses the moving direction of this point. The fuzzy inference is carried out by using Madani's method, (Table 1), and the defuzzification uses the center of gravity to compute the output of this FLC which is the duty cycle:

$$D = \frac{\sum_{j=1}^n \mu(D_j) \cdot D_j}{\sum_{j=1}^n \mu(D_j)} \quad (3)$$

The fuzzy inference engine, based on the input fuzzy sets in combination with the expert's experience, uses adequate IF-THEN rules in the knowledge base to make decisions and produces an implied output fuzzy set  $u$ . For this particular application, the proposed IF-THEN fuzzy rule base is shown in Table 1.

Table 1. The Proposed IF-THEN fuzzy rule base

$E \setminus CE \rightarrow$	NB	NS	ZE	PS	PB
NB	ZE	ZE	PB	PB	PB
NS	ZE	ZE	PS	PS	PS
ZE	PS	ZE	ZE	ZE	NS
PS	NS	NS	NS	ZE	ZE
PB	NB	NB	NB	ZE	ZE

## 3.2. Simulation Platform

A simulation platform under the MATLAB Simulink environment was developed in order to evaluate the dynamic behavior of the MG. An LV test network was built based on a system defined by NTUA and used to test both the proposed control strategies (SMO and MMO). A detailed description of the test system and its electrical parameters can be found in [20]. Figure 9 shows the MG single-line diagram. The implementation of the LV test network using the MATLAB Simulink is shown in Figure 6.

## 4. RESULTS AND DISCUSSION

Disconnection from the upstream MV network and load-following in islanded operation was simulated in order to understand the dynamic behavior of the MG and to evaluate the effectiveness of the developed control approaches. MG islanding can occur in two different situations (scheduled islanding and forced islanding) with possible faults taking place in the MV or LV grids. Due to space limitations, only results from forced islanding, due to faults in the MV grid, are described next. In this scenario, the SOFC and the SSMT are supposed to be the controllable MS used for the secondary load-frequency control using the scheme [15]. Two load/generation scenarios using the single master operation strategy with a VSI are tested, and only the SMO corresponding results are described next.

### 4.1. Single Master Operation

The scenario is characterized by a local load of 80 kW (65% of impedance type and 35% of induction motor type) and a local generation of 50 kW (high load scenario). A fault in the MV side occurred at followed by MG islanding 100 ms after. Due to the large initial frequency deviation, a certain amount of

load is automatically shed through the activation of under-frequency load shedding relays in order to aid frequency restoration. This load is later reconnected in small load steps, to avoid load disconnection by activating the under-frequency load shedding relays. Load reconnection in small steps allows the evaluation of the MG behavior under load-following conditions (see Figure 8). The principles described for current limitation in inverters can also be observed in Figure 9 for the VSI for a PQ-controlled inverter (SOFC inverter) [15]. The reacceleration of motor loads leads to a relatively slow ramping up of the voltage after fault clearing. Motor loads and asynchronous generators absorb high currents after disturbance elimination, which lead to the activation of the short-circuit current limitation function in the VSI. Terminal Voltages and Currents during and subsequent to the MV fault and islanding procedure as shown in Figure10.

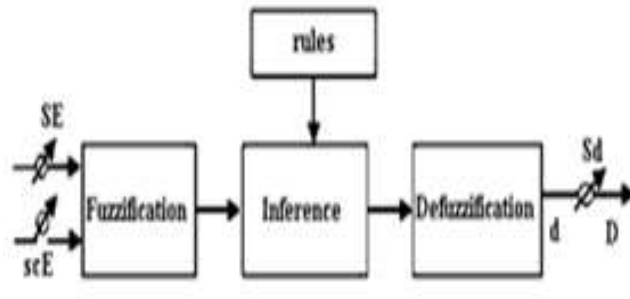

Figure 7. General diagram of fuzzy controller

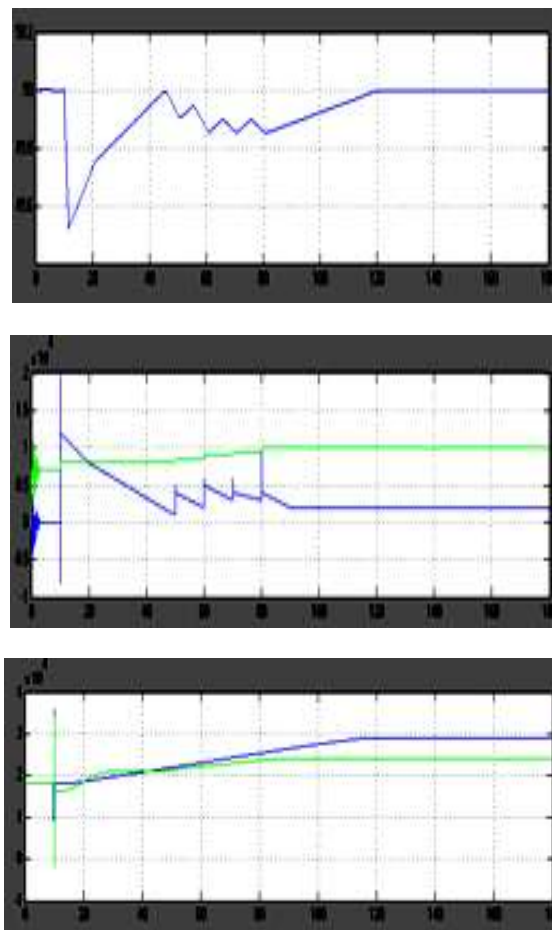

Figure 8. MG frequency, VSI active and reactive power, and SOFC and SSMT



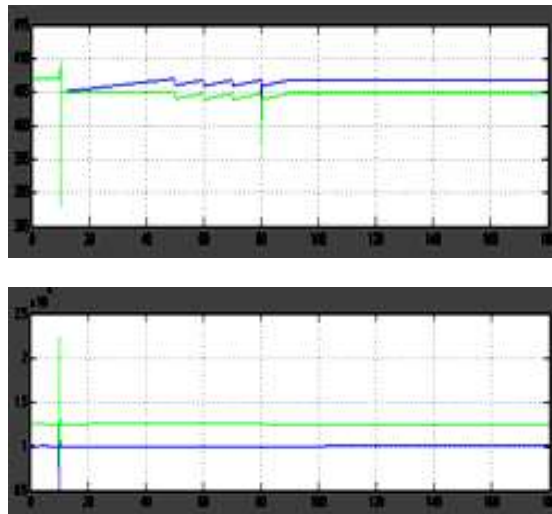

Figure 9. Voltages and reactive powers (high load scenario)

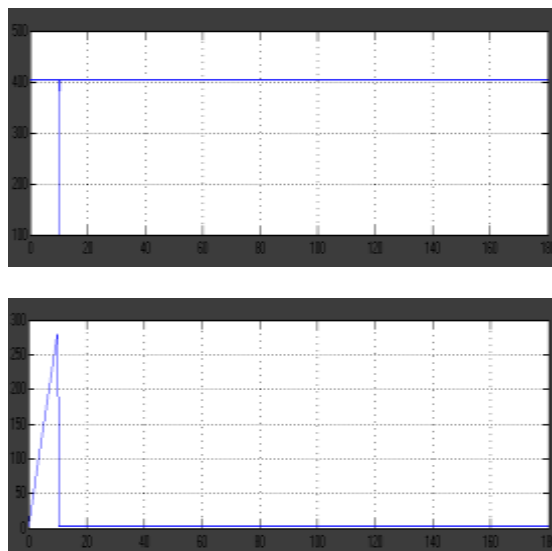

Figure 10. Terminal Voltages and Currents during and subsequent to the MV fault and islanding procedure

## 5. CONCLUSION

Simulation results indicate that the islanding of the MG can be performed safely under several different power importing and exporting conditions. Storage devices are absolutely essential to implement successful control strategies for MG operation in islanded mode with the load-shedding procedure assuming also very high importance to avoid fast and long frequency deviations. Rules and conditions to be checked during the restoration stage by the MG components were derived and evaluated through numerical simulation, proving the feasibility of such procedures.

- a. The controllers by fuzzy logic can provide an order more effective than the traditional controllers for the nonlinear systems, because there is more flexibility.
- b. A fuzzy logic MPPT controller is proposed to extract maximum possible power from a photovoltaic array. The algorithm works as a direct method of MPPT through a buck-boost converter placed in parallel with the PV array. The obtained results from simulation setup confirm that the designed system is fast, robust and efficient. The results also show the capability of the proposed FL MPPT system to track the voltage which is respective to the maximum output power. It results in

increasing the efficiency of the PV panel and reducing the bad effects of weather changing as much as possible.

### ACKNOWLEDGEMENTS

I express my thanks to the support given by management in completing my project. I also express my sincere gratitude & deep sense of respect to Dr S K Shrivastava, Head of the Department, EEE for making us available all the required assistance and for his support and inspiration to carry out this project in the Institute. I would like to thank Dr S K Shrivastava, professor who has been an inspiring guide and committed faculty who gave relief moral support in every situation of engineering career. The encouragement and support by him, especially in carrying out this project motivated me to complete this project. I am thankful to the teaching and non-teaching staff of EEE department for their direct as well as indirect help in my project. I am elated to avail my selves to this opportunity to express my deep sense of gratitude to my parents.

### REFERENCES

- [1] Henry Shu-Hung Chung, K.K. Tse, S.Y. RonHui, C.M. Mok, M.T. Ho, "A novel maximum power point tracking Technique for solar panels sing SEPIC or Cukconverter", *IEEE Transactions on power electronics*, volume 18, issue 3, May 2003 page (s): 717-724.
- [2] Lopes, J.A. Saraiva, J.T. Hatziargyriou, N. Jenkins, and N. *Management of MicroGrids*. JIEEC2003, Bilbao, 2003.
- [3] Ancona, J.J. A Framework for Power System Restoration Following a Major power Failure. *IEEE Transactions on Power Systems*, vol. 10, pp 1480-1485, 1995.
- [4] R. Lasseter *et al.* White Paper on Integration of Distributed Energy Resources—the CERTS Micro Grid Concept. European Research Project MicroGrids.
- [5] R. Lasseter and P. Piagi, "Providing premium power through distributed resources", in Proc. 33rd Hawaii Int. Conf. System Science, vol. 4, Jan. 2000.
- [6] M.C. Chandorkar, D.M. Divan, and R. Adapa, "Control of parallel connected inverters in standalone AC supply systems", *IEEE Trans. Ind. Appl.*, vol. 29, no. 1, pp. 136–143, Jan.–Feb. 1993.
- [7] J.A.P. Lopes, C.L. Moreira, and A.G. Madureira, "Defining control strategies for analysing microgrids Islanded operation", in Proc. IEEE St. Petersburg PowerTech, St. Petersburg, Russia, 2005.
- [8] F. Katiraci, M.R. Iravani, and P.W. Lehn, "Micro-grid autonomous operation during and subsequent to islanding process", *IEEE Trans. Power Del.*, vol. 20, no. 1, pp. 248–257, Jan. 2005.
- [9] T. Tran-Quoc *et al.*, "Dynamic analysis of an insulated distribution network", in Proc. IEEE Power Systems Conf. Expo., vol. 2, Oct. 10–13, 2004, pp. 815–821.
- [10] R. Caldon, F. Rossetto, and R. Turri, "Analysis of dynamic performance of dispersed generation connected Through inverters to distribution networks", in Proc. 17th Int. Conf. Electricity Distribution, Barcelona, Spain, May 12–15, 2003.
- [11] D. Georgakis, S. Papathanassiou, N. Hatziargyriou, A. Engler, and C. Hardt, "Operation of a prototype Microgrid system based on micro-sources equipped with fast-acting power electronics interfaces", in Proc. IEEE 35th PESC, vol. 4, Aachen, Germany, 2004, pp. 2521–2526.
- [12] J.A.P. Lopes, J.T. Saraiva, N. Hatziargyriou, and N. Jenkins. Management of microgrids. Presented at JIEEC2003.
- [13] Y. Zhu and K. Tomsovic, "Development of models for analysing the load-following performance of Microturbines and fuel cells", *Elect. Power Syst. Res.*, vol. 62, no. 1, pp. 1–11, May 2002.
- [14] J. Padullés, G.W. Ault, and J.R. McDonald, "An integrated SOFC plant dynamic model for power systems simulation", *J. Power Sources*, vol. 86, no. 1-2, pp. 495–500, Mar. 2000.
- [15] N. Hatziargyriou *et al.*, "Modeling of micro-sources for security studies", in Proc. CIGRE Session, 2004.
- [16] S. Barsali, M. Ceraolo, and P. Pelacchi, "Control techniques of dispersed generators to improve the continuity of electricity supply", in Proc. PES Winter Meeting, vol. 2, 2002, pp. 789–794.
- [17] M.Y. El-Sharkh, A. Rahman, M.S. Alam, A.A. Sakla, P.C. Byrne, and T. Thomas, "Analysis of active and Reactive power control of a standalone pem fuel cell power plant", *IEEE Trans. Power Syst.*, vol. 19, no. 4, pp. 2022–2028, Nov. 2004.
- [18] A. Engler, "Applicability of droops in low voltage grids", *Int. J. Distrib. Energy Res.*, vol. 1, no. 1, Jan.-Mar. 2005.
- [19] J.A.P. Lopes, C.L. Moreira, and F.O. Resende, "Microgrids black start and islanding operation", in Proc. 15th PSCC, Liege, Belgium, 2005.
- [20] R.H. Lasseter and P. Piagi, "Microgrid: A conceptual solution", in Proc. 35th PESC, vol. 6, Aachen, Germany, Jun. 2004, pp. 4285–4290.
- [21] A. Madureira, C. Moreira, and J.A.P. Lopes, "Secondary load-frequency control for microgrids in islanded Operation", in Proc. Int. Conf. Renewable Energy Power Quality, Spain, 2005.
- [22] Papathanassiou. Study-Case LV Network.

**BIOGRAPHIES OF AUTHORS**

**Mr B V Rajanna** is a student passed out from KL University from EEE Department. He obtained B.Tech degree from JNTU Kakinada in 2010 and M.Tech degree from KL University in 2015, Guntur. He had worked in different capacities in technical institutions of higher learning over 3 years. He has over 9 publications in International Journals. His Current Research includes AMR (Automatic Meter Reading) devices, Smart Metering and Smart Grids, Micro-Grids, Renewable Energy Sources, GSM/GPRS and PLC (Power Line Carrier) Communication and Various modulation techniques such as QPSK, BPSK, ASK, FSK, OOK and GMSK.



**Mr G Joga Rao** was born in srikakulam, Andhra Pradesh, India, in 1983. He received B.Tech (Electrical & Electronics Engineering) degree from Kamala Institute of Technology & Science, Jawaharlal Nehru Technological University, Hyderabad, India, in 2004 and the M.Tech degree from Jawaharlal Nehru Technological University College, Hyderabad, India in 2007. Later he joined in Chirala Engineering College, Chirala, and Andhra Pradesh as an assistant professor in the department of Electrical & Electronics Engineering and serves more than 8 years. Currently pursuing his Ph.D in SunRise University, Alwar, and Rajasthan, India. His area of interest includes Power Systems, Energy Systems, and Renewable Energy Sources, Micro Grids and Smart Grids. He is a Life Member of the Indian Society for Technical Education (LMISTE).



**Dr. S.K Shrivastava** Received B.Tech in Electrical Engineering from Nagpur University, Nagpur in 1984, M.Tech from Indian Institute of Technology IIT(B), Bombay in 1987 and Ph.D from Allahabad Agriculture University (currently Sam Higginbottom Institute of Agriculture, Technology and Sciences, Deemed University) Allahabad, Uttar Pradesh in 2006. He has more than 27 years of teaching experience in various colleges in different capacities and acted as a technical advisor and reviewer for different programmes. His area of interest includes Energy Systems and power systems. He is a life member of different professional bodies like ISTE, Fellow the Institution of Engineers (IE), The Institution of Electronics & Telecommunication Engineers.