

Modelling of a 3-phase Induction Motor under Open-phase Fault Using Matlab/Simulink

Mohammad Jannati¹, Tole Sutikno²

¹UTM-PROTON Future Drive Laboratory, Faculty of Electrical Engineering, Universiti Teknologi Malaysia, Johor Bahru, Malaysia

²Department of Electrical Engineering, Universitas Ahmad Dahlan, Yogyakarta, Indonesia

Article Info

Article history:

Received May 28, 2016

Revised Nov 2, 2016

Accepted Nov 14, 2016

Keyword:

Control purposes

D-q model

Matlab/Simulink

Open-phase fault

Star-connected 3-phase IM

ABSTRACT

The d-q model of Induction Motors (IMs) has been effectively used as an efficient method to analyze the performance of the induction machines. This study presents a step by step Matlab/Simulink implementation of a star-connected 3-phase IM under open-phase fault (faulty 3-phase IM) using d-q model. The presented technique in this paper can be simply implemented in one block and can be made available for control purposes. The simulated results provide to show the behavior of the star-connected 3-phase IM under open-phase fault condition.

Copyright © 2016 Institute of Advanced Engineering and Science.
All rights reserved.

Corresponding Author:

Mohammad Jannati,

Faculty of Electrical Engineering,

Universiti Teknologi Malaysia,

UTM Skudai, 81310 Johor, Malaysia.

Email: jannatim94@yahoo.com

1. INTRODUCTION

Induction Motors (IMs) are the most robust and the most broadly used machines in industrial sectors. To show the behavior of IMs, the modeling of these motors is very important. The modeling of these motors is needed in calculations of fault, voltage drop, control applications, transient analysis and etc [1]-[7].

Due to the complexity of the solving differential equations of a 3-phase IM, a change of variables can be applied to decrease the complexity of these equations. In this method, 3-phase windings can be reduced to a set of 2-phase windings (q-d model). In other words, the 3-phase IM stator and rotor variables are transferred to a reference frame, which can rotate at any angular velocity. This method is a powerful technique in implementing the IM equations [8].

Due to the asymmetrical structure of a 3-phase IM under open-phase fault (faulty 3-phase IM), the d-q model of a healthy 3-phase IM is different from a faulty 3-phase IM [9]. In this paper, we present a contribution to the issue of d-q model of a star-connected 3-phase IM with one phases cut-off based on [9]. The published paper in [9] investigates the d-q model of a star-connected 3-phase IM with one phase cut-off. The performance of presented model in [9] is simulated using Matlab/M-File. However, it was found that Matlab/Simulink is more convenient in terms of simplicity in structure and control algorithms.

Matlab/Simulink has benefit over other electric machine simulators in modeling the IM using d-q axis transformation. In this research, Matlab/Simulink is applied to simulate and analyze the dynamic performance of a star-connected 3-phase IM under stator winding open-phase fault condition. The provided faulty 3-phase IM model is simulated in a way that makes it understandable for the reader to follow and realize the simulation process since it gives full details about Simulink of the model equations. This paper is

organized as follows: after introduction in section 1, in section 2, the mathematical model of a star-connected 3-phase IM under open-phase fault is presented. In section 3, simulation of a faulty 3-phase IM using Matlab/Simulink is presented. To check the performance of the presented method, Matlab/Simulink results are presented in section 4. Conclusions are listed in section 5.

2. FAULTY 3-PHASE IM EQUATIONS

For the purposes of the current research, the faulty 3-phase IM equations are shown by the following equations (in these equations superscript “s” shows the use of a stationary reference frame) [9]:

Stator voltage equations

$$\begin{bmatrix} v_{ds}^s \\ v_{qs}^s \end{bmatrix} = \begin{bmatrix} r_s + L_{ds}p & 0 \\ 0 & r_s + L_{qs}p \end{bmatrix} \begin{bmatrix} i_{ds}^s \\ i_{qs}^s \end{bmatrix} + \begin{bmatrix} M_d p & 0 \\ 0 & M_q p \end{bmatrix} \begin{bmatrix} i_{dr}^s \\ i_{qr}^s \end{bmatrix} \quad (1)$$

Stator flux equations

$$\begin{bmatrix} \phi_{ds}^s \\ \phi_{qs}^s \end{bmatrix} = \begin{bmatrix} L_{ds} & 0 \\ 0 & L_{qs} \end{bmatrix} \begin{bmatrix} i_{ds}^s \\ i_{qs}^s \end{bmatrix} + \begin{bmatrix} M_d & 0 \\ 0 & M_q \end{bmatrix} \begin{bmatrix} i_{dr}^s \\ i_{qr}^s \end{bmatrix} \quad (2)$$

Rotor voltage equations

$$\begin{bmatrix} v_{dr}^s \\ v_{qr}^s \end{bmatrix} = \begin{bmatrix} 0 \\ 0 \end{bmatrix} + \begin{bmatrix} M_d p & \omega_r M_q \\ -\omega_r M_d & M_q p \end{bmatrix} \begin{bmatrix} i_{ds}^s \\ i_{qs}^s \end{bmatrix} + \begin{bmatrix} r_r + L_r p & \omega_r L_r \\ -\omega_r L_r & r_r + L_r p \end{bmatrix} \begin{bmatrix} i_{dr}^s \\ i_{qr}^s \end{bmatrix} \quad (3)$$

Rotor flux equations

$$\begin{bmatrix} \phi_{dr}^s \\ \phi_{qr}^s \end{bmatrix} = \begin{bmatrix} M_d & 0 \\ 0 & M_q \end{bmatrix} \begin{bmatrix} i_{ds}^s \\ i_{qs}^s \end{bmatrix} + \begin{bmatrix} L_r & 0 \\ 0 & L_r \end{bmatrix} \begin{bmatrix} i_{dr}^s \\ i_{qr}^s \end{bmatrix} \quad (4)$$

Torque equations

$$T_e = \frac{pole}{2} (M_q i_{qs}^s i_{dr}^s - M_d i_{ds}^s i_{qr}^s) \quad (5)$$

$$T_e - T_l = \frac{2}{pole} (Jp\omega_r + F\omega_r) \quad (6)$$

In (1)-(6), v_{ds}^s , v_{qs}^s , v_{dr}^s , v_{qr}^s , ϕ_{ds}^s , ϕ_{qs}^s , ϕ_{dr}^s , ϕ_{qr}^s , i_{ds}^s , i_{qs}^s , i_{dr}^s , i_{qr}^s are the stator voltages, the rotor voltages, the stator fluxes, the rotor fluxes, the stator currents and the rotor currents. r_s , r_r , L_{ds} , L_{qs} , L_r , M_d , M_q are the stator and rotor resistances, the stator and rotor self and mutual inductances. ω_r is the motor electrical speed. $p=d/dt$. T_e , T_l , J and F are the electromagnetic torque, the load torque, the moment of inertia and the viscous friction coefficient respectively. Moreover [9],

$$M_d = \frac{3}{2} L_{ms}, \quad M_q = \frac{\sqrt{3}}{2} L_{ms}, \quad L_{ds} = L_{ls} + \frac{3}{2} L_{ms}, \quad L_{qs} = L_{ls} + \frac{1}{2} L_{ms} \quad (7)$$

In other words, based on equation (7), during open-phase fault condition, only the stator q-axis self and mutual inductances (L_{qs} and M_q) are changed and the stator d-axis self and mutual inductances (L_{ds} and M_d) remained unchanged.

The stator and rotor voltages, fluxes and currents during open-phase fault condition are transferred to d-q axis transformation. This can be performed using the following equations [9].

$$[T_s] = \frac{\sqrt{2}}{2} \begin{bmatrix} 1 & -1 \\ 1 & 1 \end{bmatrix} \quad (8)$$

$$[T_r] = \sqrt{\frac{2}{3}} \begin{bmatrix} 1 & \frac{1}{2} & -\frac{1}{2} \\ 0 & \frac{\sqrt{3}}{2} & -\frac{\sqrt{3}}{2} \end{bmatrix} \quad (9)$$

In (8) and (9), $[T_s]$ and $[T_r]$ are transformation matrices for the stator and rotor variables respectively. As can be seen, during open-phase fault condition, the rotor transformation matrix is the same as conventional one. However, the stator transformation matrix is different. The configuration of the 3-phase power supply fed 3-phase IM during open-phase fault condition used in this paper is shown in Figure 1.

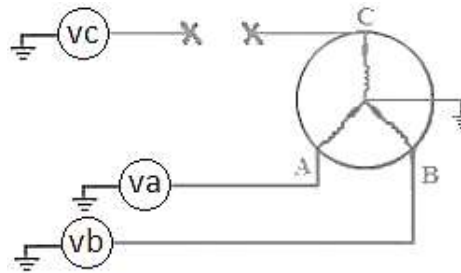

Figure 1. 3-Phase IM during Open-Phase Fault Condition

In Figure 1, the 3-phase stator voltages of an IM can be expressed as:

$$v_a = v_m \sin \omega t \quad (10)$$

$$v_b = v_m \sin \left(\omega t + \frac{2\pi}{3} \right) \quad (11)$$

$$v_c = v_m \sin \left(\omega t - \frac{2\pi}{3} \right) \quad (12)$$

3. SIMULATION OF A FAULTY 3-PHASE IM USING MATLAB/SIMULINK

In this section, a faulty 3-phase IM model is simulated using the Matlab/Simulink. The Model is implemented using the equations provided in sections 2 (equations (1)-(7)). Figure 2 shows the complete Simulink system of the described faulty 3-phase IM model. Generally, this block diagram includes five sections: rotor, stator, fluxes, transformations and torque blocks.

In this model, the simulation starts with producing stator and rotor voltages giving in equations (10)-(12), and then transforming these voltages to 2-phase voltages using transformation matrices according to the equations (8) and (9). After that, the stator, rotor, torque and flux equations in the d-q frame were implemented as below. Figure 3 shows the internal structure of the rotor for faulty 3-phase IM model. Figure 3 shows the Simulink blocks used to calculate the d-q rotor currents and d-q rotor fluxes according to the equations (3) and (4). Figure 4 shows the internal structure of the stator for faulty 3-phase IM model. Figure 4 indicates the Simulink blocks used to calculate the d-q stator currents and d-q stator fluxes according to the equations (1) and (2). Figure 5 displays the internal structure of the torque and motor speed for faulty 3-phase IM model. Figure 5 shows the Simulink blocks used to calculate the electromagnetic torque and motor speed according to the equations (5) and (6).

Finally, equations (13)-(16) indicate the internal structure of the fluxes for faulty 3-phase IM model.

$$\varphi_{md}^s = M_d i_{ds}^s \tag{13}$$

$$\varphi_{mq}^s = M_q i_{qs}^s \tag{14}$$

$$\varphi_{mdr}^s = M_d i_{dr}^s \tag{15}$$

$$\varphi_{mqr}^s = M_q i_{qr}^s \tag{16}$$

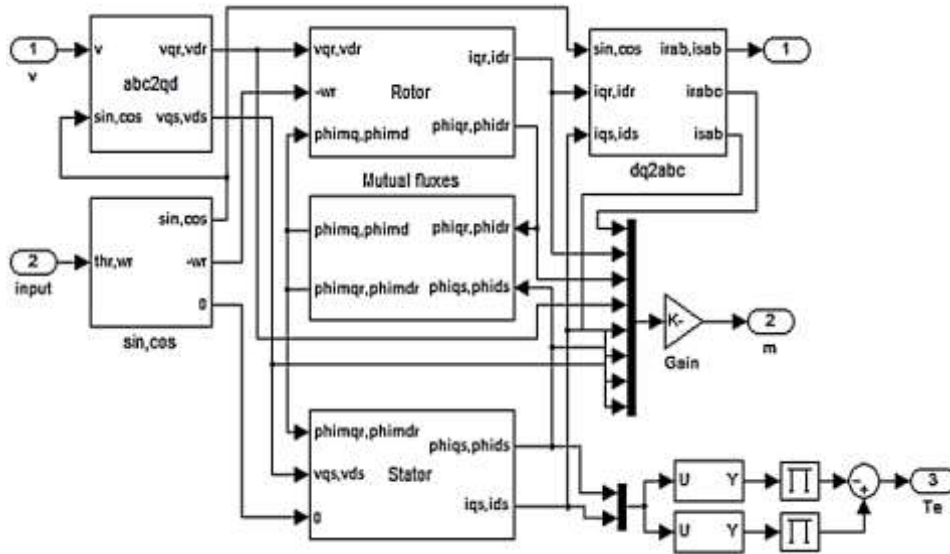

Figure 2. Complete Simulink System of a Faulty 3-Phase IM Model

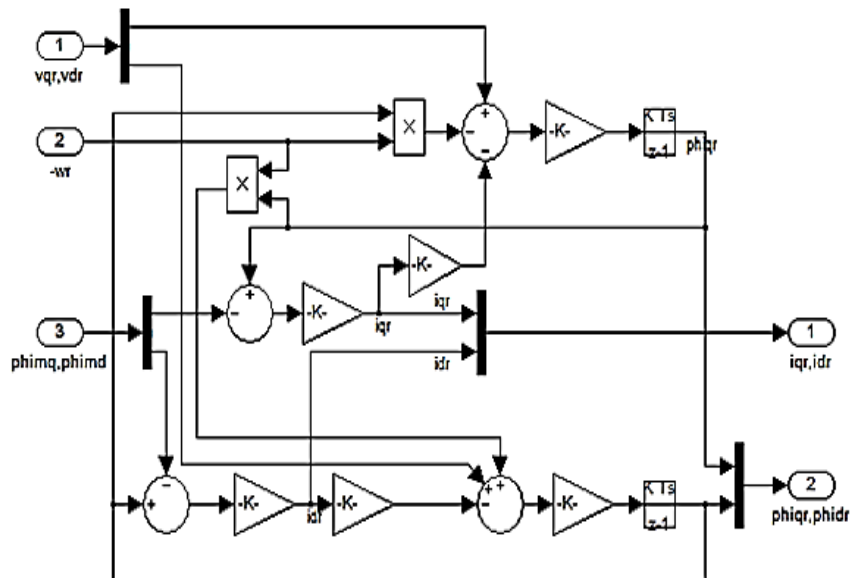

Figure 3. The Internal Structure of the Rotor for Faulty 3-Phase IM Model

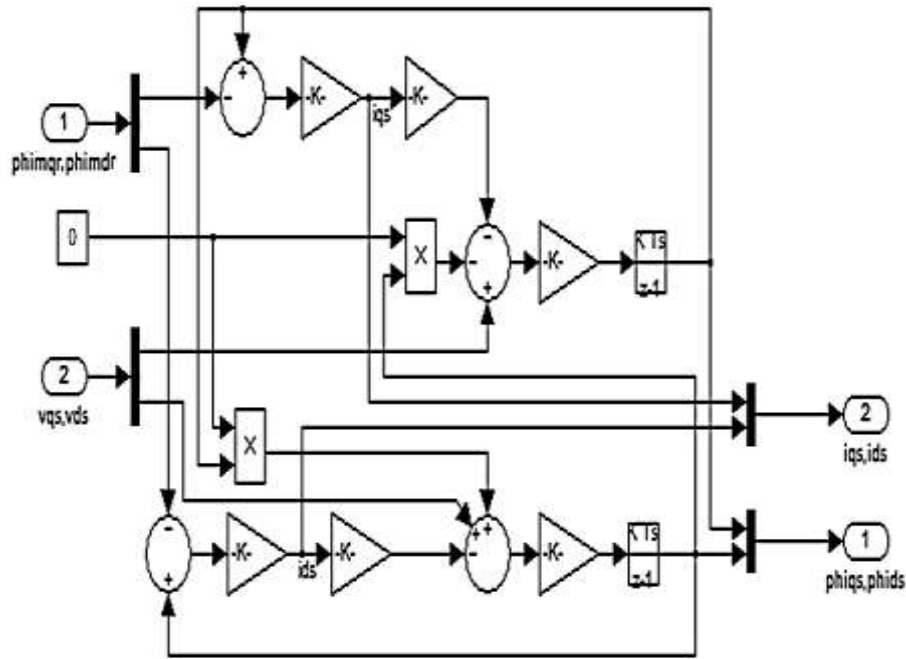

Figure 4. The internal structure of the stator for faulty 3-phase IM model

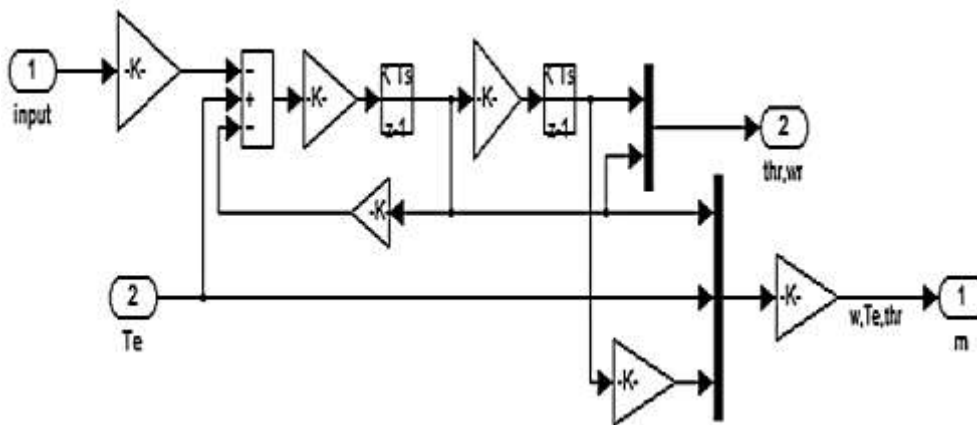

Figure 5. The Internal Structure of the Torque for Faulty 3-Phase IM Model

4. MATLAB/SIMULINK RESULTS

To show the dynamic behavior of a star-connected 3-phase IM under open-phase fault, the simulation based on Figure 2 is conducted using Matlab/Simulink. For this purpose, 4-poles, 1500rpm, 50Hz, 3-phase IM is used. The parameters of the simulated IM are as follows:

$$V_{ph}=250, r_s=2.75, X_{ls}=X_{lr}=7.3, r_r=2.25, J=0.283, X_m=68.74$$

Figure 6 shows the currents, speed and torque responses for a star-connected 3-phase IM under open-phase fault condition (Figure 6(a): no-load condition and Figure 6(b): load condition; $T_l=2$). It is concluded that, the dynamic behavior of a star-connected 3-phase IM under open-phase fault is similar to the dynamic behavior of a healthy 3-phase IM. However, in comparison to normal condition (healthy condition), the oscillations of the speed and electromagnetic torque have increased due to the open-phase fault. Furthermore, the stator currents have increased during fault condition compared with normal condition.

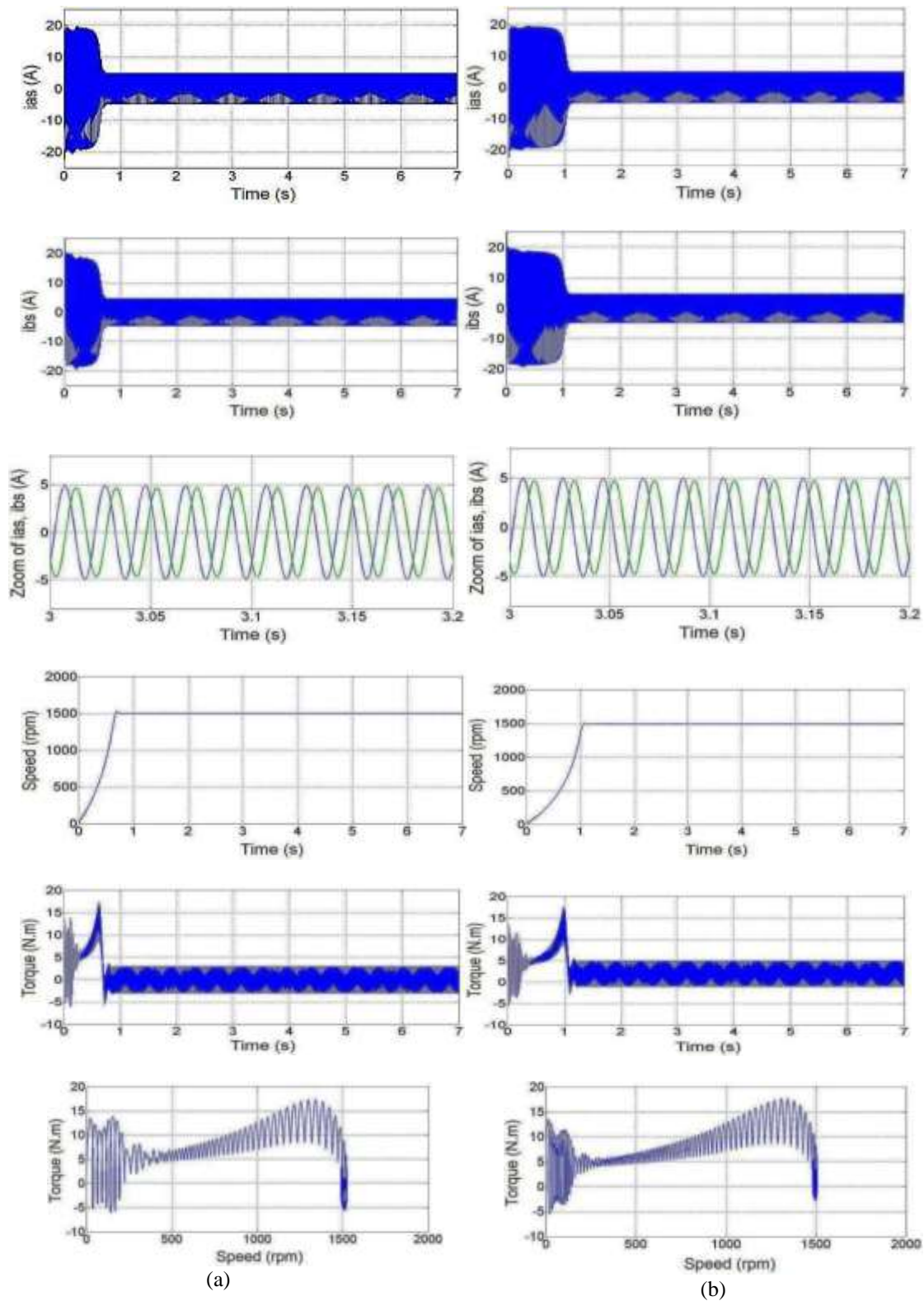

Figure 6. Simulation Results of a Faulty 3-Phase IM; (a) no-Load Condition, (b) Load Condition

5. CONCLUSION

In this research, an implementation and dynamic model of a star-connected 3-phase IM under open-phase fault condition (faulty 3-phase IM) using Matlab/Simulink are presented in a step by step method.

The presented model was verified under no-load and load conditions. It is concluded that it is possible to analyze the behavior of a faulty 3-phase IM using Matlab/Simulink with some changes in the Simulink block diagram of a healthy 3-phase IM. In the future, a study is to be conducted applying a step by step Matlab/Simulink implementation of a delta-connected 3-phase IM under open-phase fault condition.

REFERENCES

- [1] S. Li, Y. Fan, J. Fang, W. Qin, G. Lv, and J.H. Li, "HTS axial flux induction motor with analytic and FEA modeling", *Physica C: Superconductivity*, vol. 494, pp. 230–234, 2013.
- [2] S.D. Sudhoff, B.T. Kuhn, K.A. Corzine, and B.T. Branecky, "Magnetic equivalent circuit modeling of induction motors", *IEEE Transactions on Energy Conversion*, vol. 22, no. 2, pp. 259–270, 2007.
- [3] D.G. Dorrell and F. Jensen, "Modeling split-phase induction motors with center-tapped windings and asynchronous torque dips", *IEEE Transactions on Industry Applications*, vol. 45, no. 1, pp. 168–177, 2009.
- [4] E. Ramprasath and P. Manojkumar, "Modelling and Analysis of Induction Motor using LabVIEW", *International Journal of Power Electronics and Drive Systems*, vol. 5, no. 3, pp. 344–354, 2015.
- [5] J. Pedra, I. Candela, and L. Sainz, "Modelling of squirrel-cage induction motors for electromagnetic transient programs", *IET Electric Power Applications*, vol. 3, no. 2, pp. 111–122, 2009.
- [6] M. Jannati, T. Sutikno, N.R.N. Idris, and M.J.A. Aziz, "Modeling of Balanced and Unbalanced Three-Phase Induction Motor under Balanced and Unbalanced Supply Based on Winding Function Method", *International Journal of Electrical and Computer Engineering*, vol. 5, no. 4, pp. 644–655, 2015.
- [7] S.H. Asgari, M. Jannati, and N.R.N. Idris, "Modeling of three-phase induction motor with two stator phases open-circuit", In 2014 IEEE Conference on Energy Conversion (CENCON), 2014, pp. 231–236.
- [8] P.C. Krause, "Analysis of Electric Machinery", McGraw-Hill, 1986.
- [9] M. Jannati, N.R.N. Idris, and Z. Salam, "A new method for modeling and vector control of unbalanced induction motors", In *Energy Conversion Congress and Exposition (ECCE)*, 2012, pp. 3625–3632.