

## Transient and Steady State Analysis of Modified Three Phase Multilevel Inverter for Photovoltaic System

M. Venkatesan<sup>1</sup>, R. Rajeswari<sup>2</sup>, M. Kaliyamoorthy<sup>3</sup>, M. Srithar<sup>4</sup>

<sup>1,4</sup>Department of Electrical and Electronics Engineering, Karpagam University, Coimbatore, Tamilnadu, India

<sup>2</sup>Department of Electrical Engineering, Govt. College of Technology, Coimbatore, Tamilnadu, India

<sup>3</sup>Department of Electrical and Electronics Engineering, Dr. MECET, Coimbatore, Tamilnadu, India

---

### Article Info

#### Article history:

Received Sep 20, 2016

Revised Nov 25, 2016

Accepted Dec 6, 2016

---

#### Keyword:

FLC

MMLI

PI

Steady and transient state

SVPWM

---

### ABSTRACT

The transient and steady state analysis of Modified Three Phase Multilevel Inverter (MMLI) for Photovoltaic (PV) system fed from single DC input is presented in this paper. The transient and Steady state conditions of modified three phase multilevel inverter are analyzed using Proportional Integral (PI) and Fuzzy Logic Controller (FLC) with change in irradiance level of PV panels. The three phase multilevel inverter is designed with reduce number of power semiconductor switches, components, single DC input and effectively controlled by using Space Vector Pulse width Modulation technique (SVPWM). The obtained results are validated using MATLAB/Simulink. Finally, semiconductor switches and components utilization of MMLI is compared with other similar topologies.

Copyright © 2017 Institute of Advanced Engineering and Science.  
All rights reserved.

---

### Corresponding Author:

M. Venkatesan,

Department of Electrical and Electronics Engineering,

Karpagam University,

Coimbatore, Tamilnadu, India.

Email: venkatesangct@gmail.com

---

## 1. INTRODUCTION

Photovoltaic sources make use of power electronics technology in order to effectively transfer the PV energy into useful power. In response to the growing demand for medium and high power applications, Multilevel Inverters (MLIs) have been drawn more attention in PV systems in the recent years [1],[2]. There are three types of MLI topologies are: Diode clamped, capacitors clamped (Flying capacitor) and cascaded H-Bridge [3]-[5]. Among the MLIs, cascaded H-Bridge inverters have been considered in this work [6]. Classification of cascaded H- Bridge is based on the number of input DC sources, configuration of output side transformers, Number of power semiconductor switches and their control techniques. As far as DC sources are concerned, all the DC sources having an equal voltage ratio are called symmetrical inverter and DC sources which have unequal voltage ratio is called asymmetrical inverters [7].The presented MMLI is constructed using 15 power semiconductor switches for a five level inverter, use single DC input and only one three phase transformer.

The three phase multilevel inverter is modified from the references [8]-[10]. The transient and steady state performance of MMLI is analysed using PI and FLC controller and results are obtained and verified using MATLAB/Simulink. Generalized block diagram of MMLI is shown in the Figure 1.

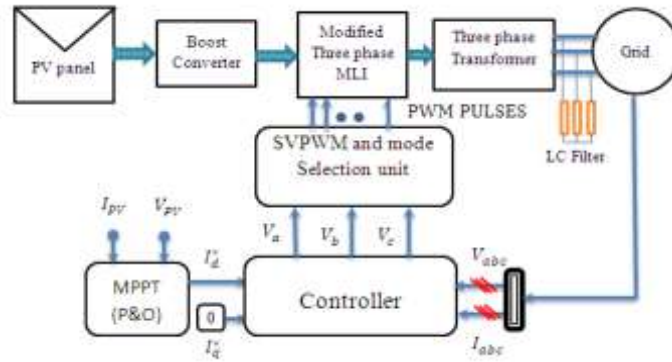

Figure 1. Block diagram of Modified three phase MLI

## 2. PHOTOVOLTAIC SYSTEM

PV cell is a semiconductor device that converts solar energy in electrical energy is termed as Photovoltaic cell and the phenomenon is called as Photovoltaic effect [11],[12]. To construct solar panel, solar cells are connected series and parallel combination for obtained higher energy levels. The electric power generated by a solar PV array fluctuates depending on the operating conditions and field factors such as the sun's geometric location, irradiation levels and ambient temperature. The Figure 2 shows the single diode model of PV cell. The typical I-V characteristic of a PV array is given by the following equation.

$$I = I_p I_{ph} - N_p I_d \left[ \exp \left( \frac{qV}{kTAN_s} - 1 \right) \right] \quad (1)$$

Where:  $I_{ph}$ - Cell photo current,  $I_d$  - Reverse saturation current of diode,  $R_p$ - Shunt resistance,  $R_{se}$ -Series resistance. PV cells are assembled in higher units called PV modules, which are further interconnected in parallel-series combination is called PV array. The PV panels are used as an input DC source for the system and obtain of the maximum power from the PV panel is necessary. So in order to get the maximum power from the PV panel Perturb and observe (P&O) a maximum power point technique (MPPT) has been used [13].

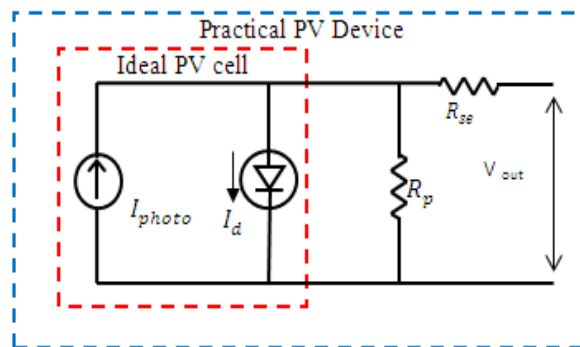

Figure 2. PV cell equivalent circuits

## 3. BOOST CONVERTER

The MMLI topology uses the PV tied boost converter. The output of the PV panels is given to the boost converter. The boost converter consists of a smoothing inductor ( $L_1$ ), MOSFET ( $S_1$ ) and diode ( $D_1$ ). The design of an inductor and the DC bus capacitor plays an important role and higher frequency is chosen for designing the inductor, in which the volume of the inductor can be reduced. Furthermore, interference can be minimized through the selection of higher frequency ranges. The DC-DC boost converter is used to increase required the voltage level. This is done by changing the duty cycle of a MOSFET. The equivalent circuit of the boost converter is shown in the Figure 3.

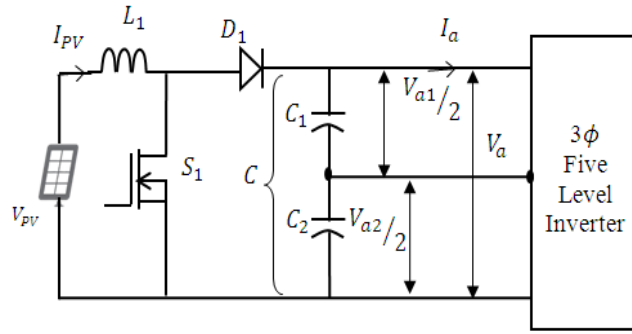

Figure 3. Equivalent circuit of boost converter

**4. MODIFIED THREE PHASE MULTILEVEL INVERTER TOPOLOGY**

The power circuit diagram of PI/ FLC based three phase five level PV inverter along with the common DC source system is presented in [14] and it is illustrated in Figure 4.

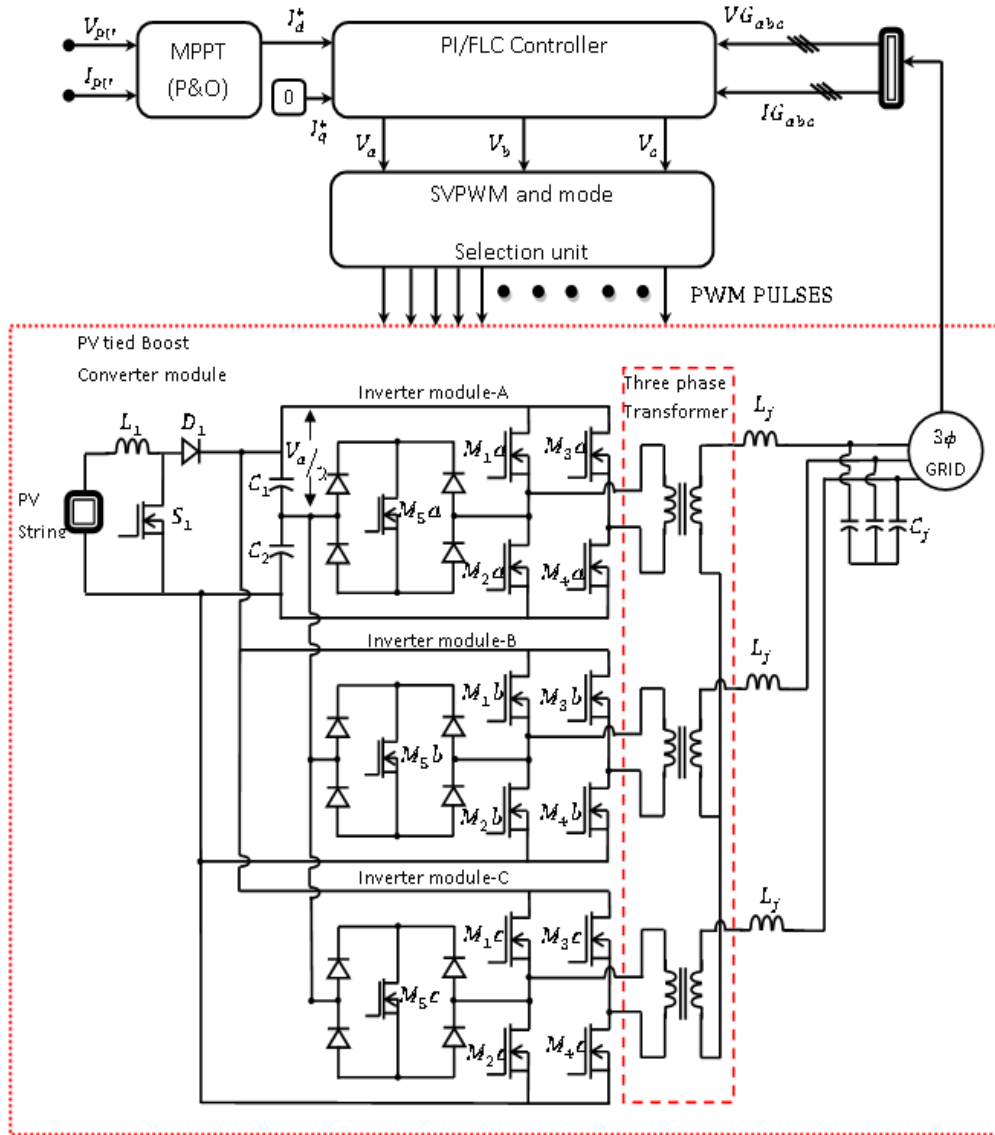

Figure 4. Power circuit of MMLI fed from single DC source

It comprises of a PI/FLC based control system; PV tied boost converter, three phase five level inverter, a single DC input, three phase transformer. The DC bus formed by connecting two capacitors is connected in series and both are equal values. The output voltage of each single inverter mainly depends on the voltage range of DC bus. Usually, DC bus voltage should be fixed higher than the output voltage of the inverter. Each single phase inverter is constructed with normal H-Bridge inverter along with auxiliary inverter. Here auxiliary consists of single power switch along with four power diode [10]. The auxiliary inverter and one leg of H-bridge inverter operate at carrier frequency range and another leg of H-Bridge inverter is operating fundamental frequencies. Each single phase inverter can generate five level output voltage from common DC bus. The outputs of the inverters are given to the 1:1 three phase 12 terminal transformers and then fed to the three phase grid.

## 5. SIMULATION RESULTS AND DISCUSSION

The presented PI/FLC based MMLI for PV application with single DC input is simulated in a MATLAB/Simulink. The MMLI is controlled by using PI/FLC and performances of MMLI have been evaluated through FLC. Moreover, performances of FLC are validated and compared with conventional PI controller. The MMLI is designed with 400V rms and 5.5A rms. The solar panel is used as a input source and DC-DC boost converter with P&O algorithm is used to track the MPP from PV panel at different climatic conditions. In order to generate PWM pulses to the inverter switches, by comparing to reference signals (SVPWM) and high frequency carrier signal [15] is shown in the Figure 5. The performances of MMLI is examined through both transient and steady state conditions.

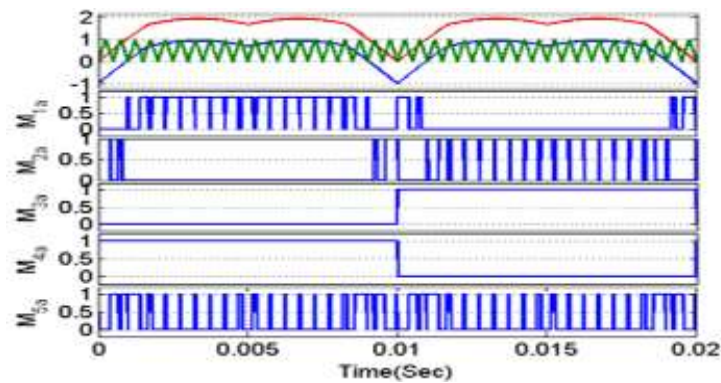

Figure 5. PWM Pulse Generations

### 5.1. Steady state analysis

The steady-state analysis of the proposed MMLI is discussed in this section. The appropriate current controller and control loop is needed for proper synchronization of three phase grid. In current control loop the reference ( $I_d^*$ ) is tracked from MPPT algorithm and ( $I_q^*$ ) is set to zero. The actual ( $I_d$ ) and ( $I_q$ ) is generated from the inverter current using park transformation. Now the actual and reference direct currents ( $I_d$ ) and ( $I_d^*$ ) is compared and the error of direct current ( $I_{de}$ ) is given as input to the PI/FLC. Similarly the quadrature current error is given to the input of PI/FLC. The direct and quadrature current errors ( $I_{de}$  and  $I_{qe}$ ) are shown in Figure 6.

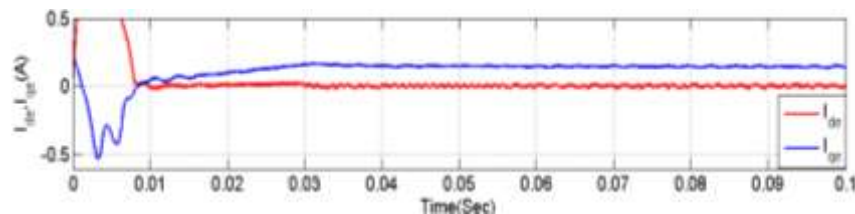

Figure 6. Direct and quadrature current errors

The controlled error ( $V_{id}$  and  $V_{iq}$ ) of PI/FLC is shown in Figure 7. As shown from the figure the FLC based tuning approach is effectively optimize the error with minimal steady state error compared with PI controller based tuning approach. The controlled output ( $V_{id}$  and  $V_{iq}$ ) i.e. two phase quantity is superimposed with grid components and further transformed into three phase quantity using inverse park transformation. As shown from the Figure 8 the DC bus voltage of MMLI is tightly regulated using FLC with minimal peak over shoot and peak under shoot. The utilization of the DC bus voltage is significantly improved compared to the PI controller.

The achieved power quality indices like Power Factor (PF) and reactive power of MMLI are shown in Figure 9 and 10 respectively. The achieved PF is maintaining near unity when the FLC based current control method, consequently reactive power also minimized compared with PI controller based tuning method. The three phase reference voltage is generated from the current control loop is processed with logical operation for create the five level output.

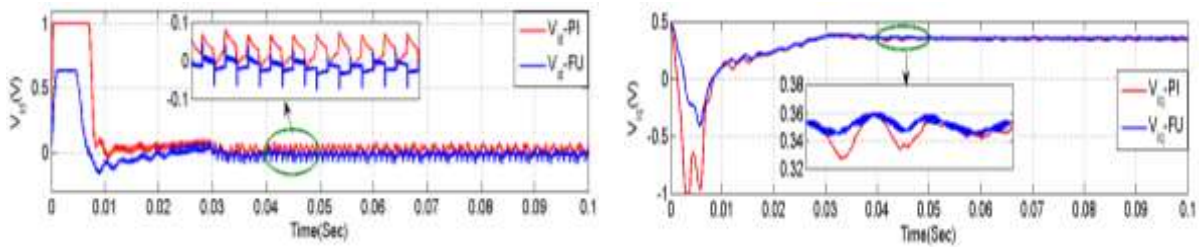

Figure 7. (a)  $V_{id}$  and  $V_{id}$  of PI-Fuzzy (b)  $V_{iq}$  and  $V_{iq}$  of PI-Fuzzy

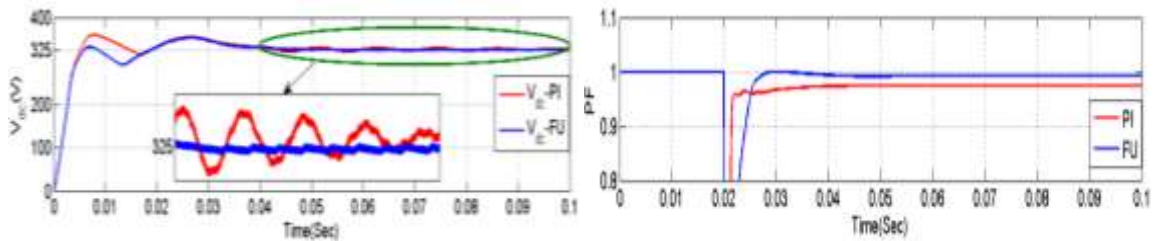

Figure 8. DC Bus Voltage ( $V_{dc}$ -PI and Fuzzy)

Figure 9. Power factor

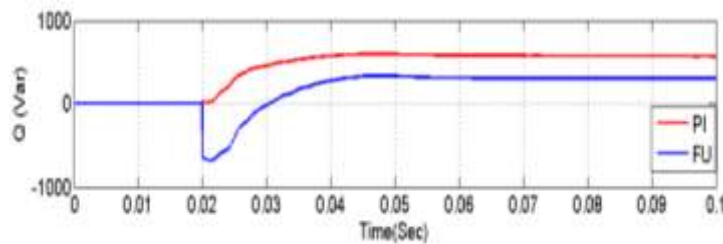

Figure 10. Reactive power

**5.2. Transient state analysis**

The transient analysis of MMLI is obtained by sudden variation of solar irradiation and reference current is shown in Figure 11 (a) and (b). Five level output voltage and current is shown in the Figure 12 (a) and (b) It is observed from the Figure 12 (a) and 12 (b), the amplitude variation of the inverter voltage and inverter current clearly shows the efficient closed loop control of the active power filter system. Power factor of the both PI and FLC controller is shown in the Figure 13. It observed that, power factor of the MMLI is nearest unity.

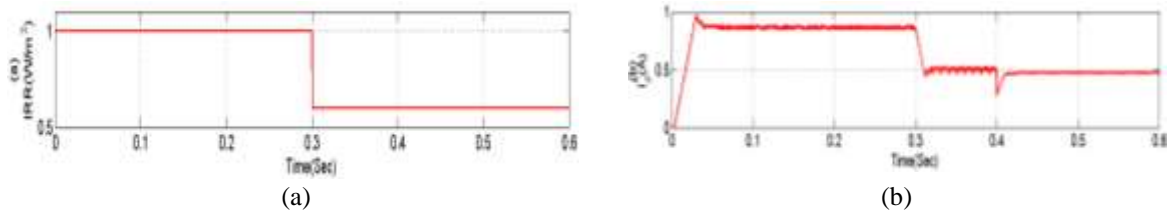

Figure 11. Transient state conditions a) Solar irradiation b) Reference current ( $I_d^*$ )

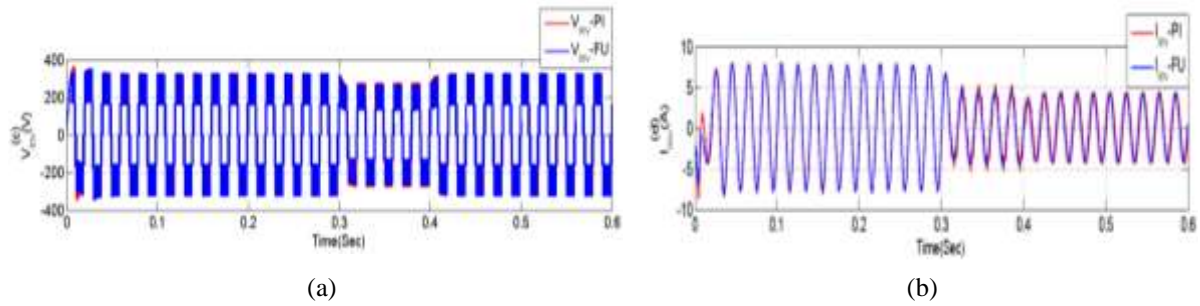

Figure 12. Transient state condition a) Five level output b) Inverter current

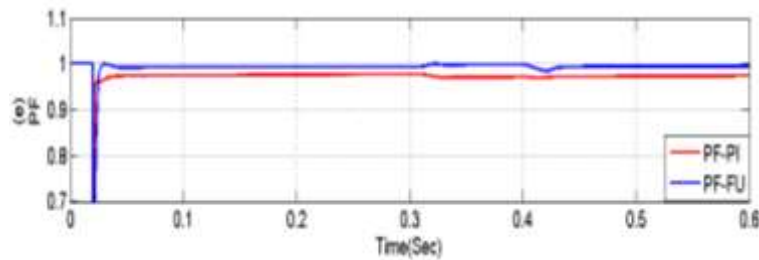

Figure 13. Power factor

The solar irradiation waveform is shown in Figure 11. In order to evaluate the dynamic performance of the system the full irradiation ( $1W/m^2$ ) is maintained till 0.3 Sec., and then the solar irradiation is suddenly reduced ( $0.6W/m^2$ ) from 0.3 sec. to 0.6 sec as shown in Figure 11 (a). Figure 11(b) shows the corresponding reference ( $I_d^*$ ) current from MPPT algorithm. The three phase fivelevel inverter output voltage is equal to 325 V peak and it is shown in Figure 14. The filtered three phase inverter current (7.7Apeak) and voltage (575Vpeak) is shown in the Figure 15. It is shows that, sinusoidal current waveform is inphase with grid voltage.

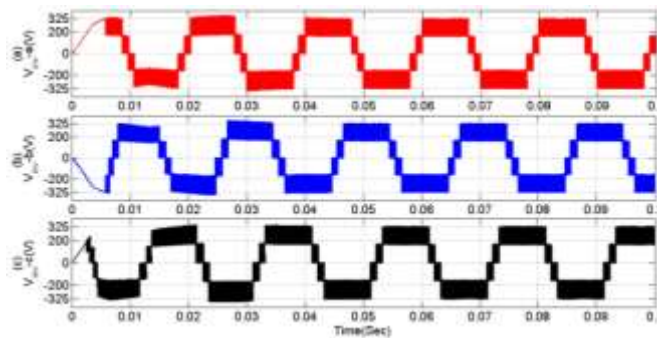

Figure 14. Five level output voltage

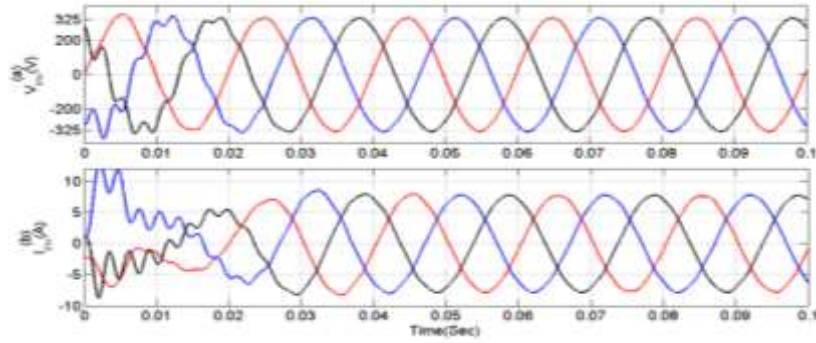

Figure 15. Three phase voltage and current

### 5.3. Comparison of semiconductor devices and components

Table 1 shows the comparison of a number of power devices used in this topology with three topologies existing topologies as referred in [7]-[9]. The device comparison mainly includes the power semiconductor switches, number of input DC source, and transformer used. This topology uses only 15 switches (Excluding boost converter), one transformer, a single input DC source, and two DC link capacitors. So, totally 19 numbers of devices and components are used. From the Table.1, it is clearly observed that the proposed MMLI uses lesser device utilization compared to others. This in turn would result in lesser complexity and cost.

Table 1. Semiconductor devices and components comparison of the proposed MMLI with others

References	Number of Power Devices				Total
	Switches	Transformers	Input DC sources	DC bus Capacitors	
[7]	24	-	6	6	36
[8]	24	6	1	1	32
[9]	24	2	1	1	28
Proposed Topology	15	1	1	2	19

In comparison with the other topologies, the presented topology has comparatively lesser number of components and the least number of conducting devices and operated in faster. The DC bus voltage of the proposed system is effectively utilized because of the implementation of SVPWM technique and the proposed MMLI was controlled by using both PI and FLC and their results were compared. The proposed MMLI uses a single DC source for the entire PV inverter and only one three phase transformer. Hence, size and cost of the proposed MMLI is reduced considerably.

## 6. CONCLUSION

In this paper presents transient and steady state analysis of modified three phase multilevel inverter for PV system. The presented PI/FLC controlled MMLI topology has been designed and simulated using MATLAB/Simulink. Simulation results prove that, the steady and transient state performances of MMLI have been evaluated with PI/FLC. FLC offer significantly improved performance in terms of peak overshoot, peak undershoot and setting time. Hence, designed FLC gives better performance compared with PI controller.

## ACKNOWLEDGEMENTS

The authors thank Department of Electrical Engineering, Govt. College of Technology, Coimbatore, Tamilnadu, India for providing us the Licensed Software-MATLAB Version 8.3R2014a which was procured under TEQIP (Technical Education Quality Improvement Program)-Phase-II-Sub Module-Center of Excellence-Alternate Energy Research and also authors thank to Management of Karpagam University for providing the necessary facilities.

## REFERENCES

- [1] V. G. Agelidis *et al.*, "A Multilevel PWM Inverter Topology for Photovoltaic Applications," Proceedings of the IEEE International Symposium on Industrial Electronics (ISIE'97), vol. 2, pp. 589-594, 1997.
- [2] K. S. Srikant, "A Three Phase Multi Level Converter for grid Connected PV System," *International Journal of Power Electronics and Drive Systems*, vol. 5, pp. 71-75, 2014.
- [3] M. Venkatesan, *et al.*, "Comparative Study of Three Phase Grid Connected Photovoltaic Inverter Using PI and Fuzzy Logic Controller with Switching Losses Calculation," *International Journal of Power Electronics Drives Systems*, vol.7, pp. 543-550, 2016.
- [4] M. Kaliamoorthy, *et al.*, "Experimental Validation of a Cascaded Single Phase H-Bridge Inverter with a Simplified Switching Algorithm," *Journal of Power Electronics*, vol. 10, pp. 507-518, 2014.
- [5] N. Deverajan and A. Reena, "Reduction of Switches and DC Sources in Cascaded Multilevel Inverter," *Bulletin of Electrical Engineering and Informatics*, vol. 4, pp. 186-195, 2015.
- [6] Chetanya, *et al.*, "Harmonic Analysis of Seven and Nine Level Cascade Multilevel Inverter using Multi-Carrier PWM Technique," *International Journal of Power Electronics and Drive Systems*, vol. 5, pp. 76-82, 2014.
- [7] I. Colak, *et al.*, "Review of multilevel voltage source inverter topologies and control schemes," *Energy Conversion and Management*, vol. 52, pp. 1114-1128, 2011.
- [8] A. K. Panda and Y. Suresh, "Research on cascade multilevel inverter with single DC source by using three-phase transformers," *Electrical Power and Energy Systems*, vol. 40, pp. 9-20, 2012.
- [9] S. G. Song, *et al.*, "Cascade multilevel inverter employing three phase transformer and single DC input," *IEEE Transactions on Industrial Electronics*, vol. 56, pp. 2005-5014, 2009.
- [10] N. A. Rahim and J. Selvaraj, "Multistring Five-Level Inverter with Novel PWM Control Scheme for PV Application," *IEEE Transactions on Industries Electronics*, vol. 57, pp. 2111-2123, 2010.
- [11] S. Jain and V. Agarwal, "Comparison of the performance of maximum power point tracking schemes applied to single stage grid-connected photovoltaic systems," *IET Electric Power Applications*, vol. 1, pp. 753-762, 2007.
- [12] D. V. N. Ananth and G. V. Nageshkumar, "Design of Solar PV Cell Based Inverter for Unbalanced and Distorted Industrial Loads," *Indonesian Journal of Electrical Engineering and Informatics*, vol. 3, pp 70-77, 2015.
- [13] A. Soetedjo, *et al.*, "Modeling of Maximum Power Point Tracking Controller for Solar Power System," *TELKOMNIKA*, vol. 10, pp. 419-430, 2012.
- [14] M. Venkatesan, *et al.*, "Implementation of a modified SVPWM-based three-phase inverter with reduced switches using a single DC source for a grid-connected PV system," *Turkish Journal of Electrical Engineering and Computer Sciences*, vol. 24, pp. 3023-3035, 2016.
- [15] M. Venkatesan, *et al.*, "A Fuzzy logic Based three phase inverter with single DC source for grid connected PV system employing three phase transformer," *International Journal of Renewable Energy Research*, vol. 5, pp. 739-745, 2015.

## BIOGRAPHIES OF AUTHORS



**Venkatesan M** was received his B.E., in Electronics and communication Engineering from Anna University, Chennai, Tamil Nadu, India, in 2008, and his M.E. in Power Electronics and Drives from Government college of Technology, Coimbatore, Tamil Nadu, India, in 2010. He is currently working towards to his Ph.D and also working as an Assistant Professor in the Department of Electrical and Electronics Engineering, Faculty of Engineering, Karpagam University, Coimbatore, Tamil Nadu, India. His current research interests include Power electronics, DC-DC converter, Multilevel inverter, PV based system design. He is Associate member of the Institution of Engineers (India).



**Rajeswari R** was received her B.E., in Electrical and Electronics Engineering and M.E. in Power Systems Engineering from Thiagarajar College of Engineering, Madurai Kamarajar University, Madurai, Tamil Nadu, India, in 1995 and 1998 respectively. She was completed her Ph.D in Power Systems Engineering in 2009, Anna University, Chennai, Tamilnadu, India. She is currently working as an Assistant Professor (Senior Grade) in the Department of Electrical and Electronics Engineering, Government College of Technology, Coimbatore, Tamil Nadu, India. More than Ten scholars are pursuing research under her Guidance. Her current research interests include Smart Grid, Power system protection, operation & control and intelligent control techniques.





**Kaliamoorthy M** was received his B E in Electrical and Electronics Engineering at Madras University, Chennai, India, in 1999, and his M.Tech degree in Electrical Drives and Control from Pondicherry University, Puducherry, India, in 2006. He was a gold medalist for the academic years 2004-2006. He was completed his Ph.D in Power Electronics and drives in 2015, Anna Uiversity, Chennai, Tamilnadu, India. He has one decade of teaching experience for under graduate and post graduate students of electrical and electronics engineering. He is presently working as a Professor in the Department of Electrical and Electronics Engineering, Dr. MCET, Pollachi, Tamil Nadu, India. His current research interests include alternative energy sources, fuel cells, energy conversion, multilevel inverters, analysis and control of power electronics devices, power quality and active harmonic analysis.



**Srithar M** was received his B.E., in Electrical and Electronics Engineering from Government college of Technology Coimbatore, Tamil Nadu, India, in 2013 and his M.E. in Power systems Engineering from Anna Uiversity, Chennai, 2016.