

Design Improvement of Three Phase 12Slot-14Pole Outer Rotor Field Excitation Flux Switching Motor

S. M. N. S. Othman¹, M. Z. Ahmad², J. A. Rahim³, F. S. Bahrim⁴, E. Sulaiman⁵

^{1,2,3,4,5} Research Centre for Applied Electromagnetics, Universiti Tun Hussein Onn Malaysia
86400 Parit Raja, Johor, Malaysia

Article Info

Article history:

Received Oct 11, 2016

Revised Dec 17, 2016

Accepted Dec 27, 2016

Keyword:

12Slot-14Pole

Deterministic method

Field excitation coil

Finite-element analysis

Flux switching motor

ORFEFSM

ABSTRACT

This paper present with design improvement of 12Slot-14Pole outer rotor field excitation flux switching motor (ORFEFSM) from the initial design by implement Deterministic Optimization Method (DOM) which involve 2-dimensional Finite-Element Analysis (FEA). The design improvement starts with the non-active part, rotor and followed with active part, stator which involve the armature coil slot and field excitation coil (FEC) slot. Since it is one of local optimization method, this method involves more than one cycle of improvement depends on the design structure and slot-pole configuration until achieve optimum performance. However, the initial torque and power output of 12Slot-14Pole is 112.95 Nm and 50.46 kW. The main objective is to improve the structure in order to obtain optimum torque and power output. Besides, it is necessary to reduce flux saturation and optimize the flux flow between the rotor teeth and stator arc width. The target torque and power output performance is expected higher than 210 Nm and 123 kW. With the deterministic optimization method technique, the final torque and power output achieved are 221.83 Nm and 189kW.

*Copyright © 2017 Institute of Advanced Engineering and Science.
All rights reserved.*

Corresponding Author:

E. Sulaiman,

Research Centre for Applied Electromagnetics,

Universiti Tun Hussein Onn Malaysia,

86400 Parit Raja, Johor, Malaysia.

Email: erwan@uthm.edu.my

1. INTRODUCTION

Flux Switching Motor (FSM) that comprise of all flux source in the stator have been developed in recent years due to their advantage of single robust rotor structure suitable in high speed application [1]–[3]. From here on, more and more researchers doing research on applying principle flux switch to design an electric machine [4]–[6]. Generally, the flux switching motor (FSM) can be categorized into three groups that are permanent magnet flux switching motor (PMFSM), field excitation flux switching motor (FEFSM), and hybrid excitation flux switching motor (HEFSM). Figure 1 illustrates the classification of FSM [7]. Their rotors are salient and robust without windings or permanent magnet (PM), and are matching to that of switched reluctance machines. Consequently, they are very robust. As the active part are on the stator, the temperature rise may be more managed [8],[9]. Furthermore, an outer-rotor flux switching motor have also been research as consideration to applied it to a direct drive application for electric vehicle [10]–[13]. In general, the propulsion system for conventional electric vehicle (EV) require more space or high gear ratio to the wheels. Thus, outer-rotor configuration leads to reduction gear ratio and reduce the total weight of a vehicle [7],[14]. Even though a double rotor have been the main consideration for low torque and low speed, an exceptional design than existing electric motor are essential for research and development for good performance [15]. Furthermore, an economical motor such as non-permanent magnet, simple construction

with low size and weight would be very crucial and benefits for mankind. Early examples of inner-rotor FEFSM, the three-phase 12S-14P FEFSMs are developed as shown in Figure 2 [16].

This study presents an investigation and optimization study of 12S-14P outer-rotor FEFSM. In this electric motor design, the capability of FEC makes the machine more attractive especially for the modulating of flux. Initially, the design study of the proposed electric motor was reported as discussed [17]. However, based on initial analysis using 2D-FEA, the proposed motor have shortcoming that prevent them to achieve maximum performances especially at maximum current density. To improve the design drawbacks, design optimization by deterministic optimization method (DOM) were conducted. The proposed initial design are illustrated in Figure 3(a). In the meantime, Figure 3(b) shows the design after optimization take place. The study on optimization shall be done to ensure the optimum performance of the design with new structure to give higher output torque and power.

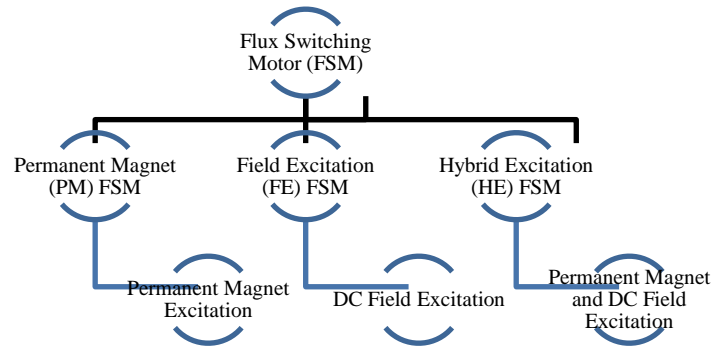

Figure 1. Classification of Flux Switching Motor (FSM)

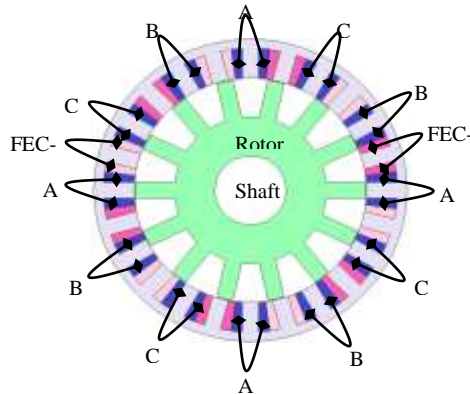

Figure 2. Initial design of 12S-14P FEFSM

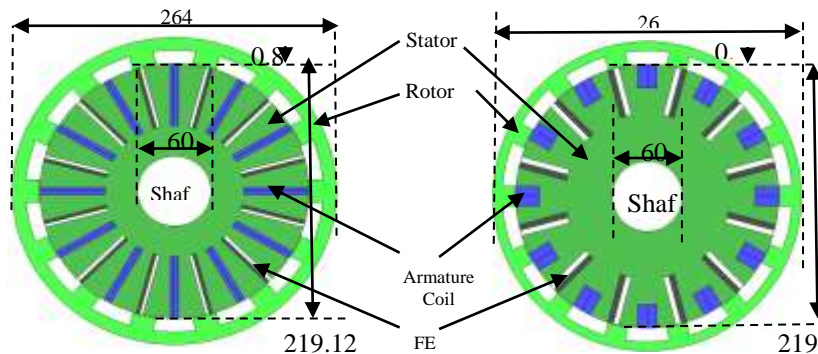

Figure 3. (a) Initial design of 12Slot-14Pole OR-FEFSM (b) Optimized design of 12Slot-14Pole OR-FEFSM

2. RESEARCH METHODOLOGY

Design improvement is conducted by updating seven individual parameters identified as P1 to P6. This P1-P6 design parameters are sensitive towards the improvement of machine performance and defined in two major part, the rotor and stator part. Then the design parameter are divided in three group for applying deterministic method, such as rotor parameter (P1-P3), DC-FEC parameter (P4-P5) and armature coil, AC parameter (P6) and all the design parameter can be illustrated in Figure 4.

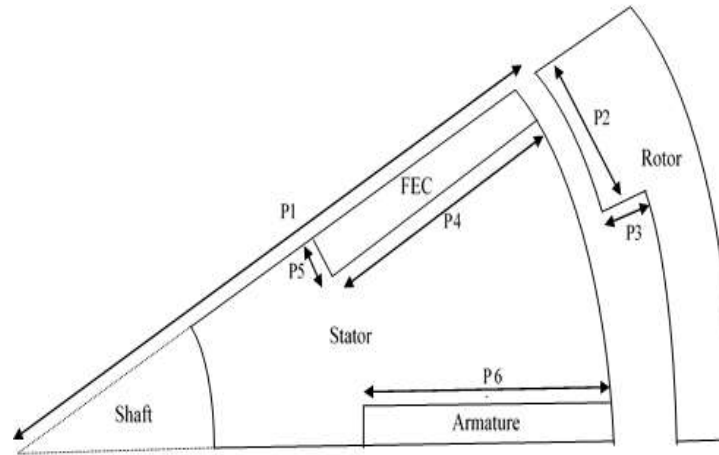

Figure 4. Design parameter defined as P1-P6

2.1. Design Improvement Process

Figure 5 shows the cycle of design improvement for this design. This method is executed consecutively to the design until achieve an optimum performances of the machine. Each parameter P1-P6 of the electric motor design contributes to the increase in torque performance and lessen a flux saturation. The first step is carried out by changing the rotor parameters, P1, P2 and P3 while keeping P4-P6 as constant. Theoretically, torque is directly proportional to the rotor parameter, P1-P3 with the motor diameter remain constant, 264mm. Therefore, the rotor radius can be presumed as one of the dominant parameters to increase torque performances and lessen flux saturation at the rotor teeth. As for rotor pole height, P2 are improving to allow the flux to flow from the stator to rotor with low flux saturation and flux leakage. The other parameters remained constant when changing the pole height, P2. The rotor width P3 improvement prone to receive all flux from stator teeth by the increase in space and width. The rotor parameter of P1, P2 and P3 are then updated to get an optimum torque.

The next group of parameters will be the FEC group P4-P5, and other parameters are kept constant when changing the DC-FEC parameters. DC-FEC slot width, P5 and DC-FEC slot depth, P6 do help to contribute towards the increment of machine torque output. This is because the increase of the DC-FEC slot area, help to improve more flux linkage with the increase of No. of Turn (NoT) against current to be injected to the DC-FEC. The P4 and P5 parameter are adjusted to obtain the optimum performance and produced a higher torque. Once the maximum torque for rotor and FEC are determined, the final step will be done by improve the armature coil, AC slot or armature coil, AC slot length, P6. By decreasing the armature coil slot length and maintain the slot area will directly result in higher width of armature coil slot. Thus, it adjusted with the stator tooth width and cause magnetic flux to concentrate and flow into the rotor. Hence, deterministic optimization method is treated consecutively by varied P1-P6 until the target maximum torque and power are achieved.

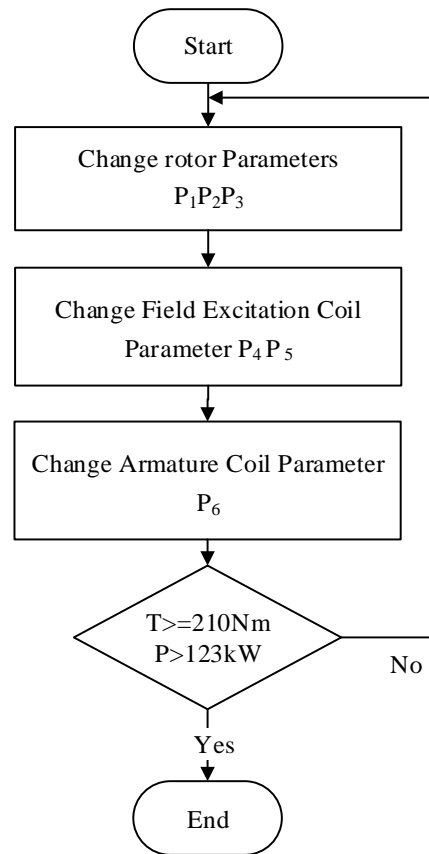

Figure 5. Cycle of design optimization

2.2. Design Parameter and Specification

The design restrictions, target specifications and parameters of both initial and optimized design of ORFEFSM are listed in Table 1. Assuming water jacket system is employed as the cooling system for the machine, the limit of the current density is set to have maximum at $30A_{\text{rms}}/\text{mm}^2$ for armature winding and $30A/\text{mm}^2$ for DC-FEC, respectively. It can be expected that the rotor structure is mechanically robust to rotate at high-speed because it consists of stacked soft iron sheets, which the target maximum operating speed is elevated up to 20,000r/min.

Table 1. Design Parameters and Specification

Items	12S-14P ORFEFSM	
	Initial	Optimize
Max. current density in armature winding, J_a ($A_{\text{rms}}/\text{mm}^2$)	30	30
Max. current density in excitation winding, J_e (A/mm^2)	30	30
Outer diameter of motor (mm)	264	264
Motor stack length (mm)	70	70
Air gap length (mm)	0.8	0.8
Rotor radius, P1 (mm)	110.36	114.36
Rotor pole width, P2 (mm)	22.71	19.46
Rotor pole depth, P3 (mm)	10.82	13.82
FEC height, P4 (mm)	53.04	36.09
FEC width, P5 (mm)	2.76	4.77
Armature coil height, P6 (mm)	53.04	26.04
No. of turns of Armature coil, N_a	7	6
No. of turns of FEC, N_e	44	44

2.3. Under No-Load and On Load Condition Analysis

Thereupon, the analysis under no-load and on load condition is fulfilled and compared with the initial design analysis that have been accomplished. From the analysis, the back-emf and cogging torque are investigated at 1200r/min. On load condition, a flux distribution is investigated when J_e and J_a at maximum $30\text{A}/\text{mm}^2$ and $30\text{A}_{\text{rms}}/\text{mm}^2$, respectively. The final design is expected to reduce the flux saturation in order to generate more flux linkage and increase the overall performance of the design.

3. RESULTS AND ANALYSIS

3.1. Induced Voltage

The comparison of induced voltage of initial and final design 12Slot-14Pole OR-FEFSM at the speed of 1200rpm is illustrated in Figure 6. Induced voltage for initial design are 137.2V, while the induced voltages for final designs are 177.15V respectively. Figure 6 clearly shown that the amplitude of induced voltage for the final design motors has been increase. The maximum induced voltage increase by 29.12% from its initial value. Induced voltage depends on the maximum flux linkage, since the maximum flux linkage increase, the induced voltage are affected. Importantly, the harmonics is significantly reduced and the induced voltage did not exceed the supply voltage, which is good for performance of the motor because it will not interrupt the operation of the motors as it is use for regenerative brake to charge battery.

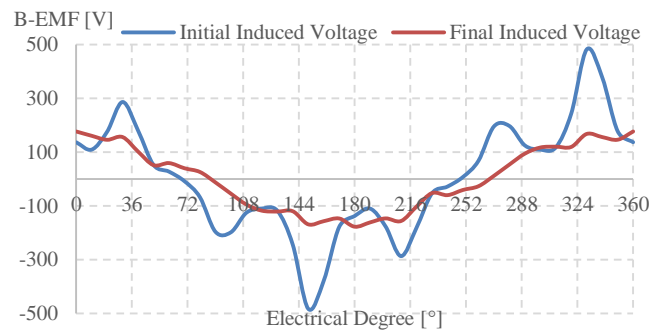

Figure 6. Induced voltage of the initial and optimize design

3.2. Cogging Torque

The cogging torque characteristic for initial and improved design is shown in Figure 7. From the figure, it is clearly shown that the peak to peak cogging torque of the improved design is increase by 15.59 Nm increase with 7 times more than initial design for 12S-14P, which is 2.1 Nm. General theory expected that the torque and power will be improved with less vibration and noise as compared to initial design although the final cogging torque increase because in high speed region the cogging torque will be negligible. Besides, the cogging torque increment still below 10% of the instantaneous torque. Explaining research chronological, including research design, research procedure (in the form of algorithms, Pseudocode or other), how to test and data acquisition [1]-[3]. The description of the course of research should be supported references, so the explanation can be accepted scientifically [2],[4].

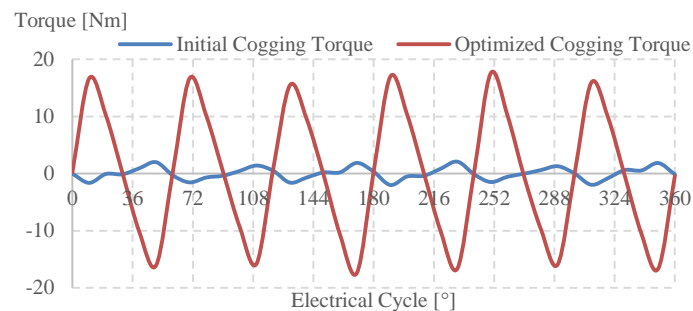

Figure 7. Instantaneous torque characteristics of initial and optimized design

3.3. Instantaneous Torque Characteristics Equations

The instantaneous torque is demonstrated in Figure 8 respectively. It is shown that the maximum torque of the improved design able to achieve approximately 59% more torque than the initial torque performance. Nevertheless, 12S-14P able to achieve targeted torque, 210Nm from 112.95Nm to 221.83Nm, which is 96.4% higher than initial and 5.63% higher than targeted torque. It is comprehensible that an increase in the armature current density will increase the torque performance, thus a maximum torque was achieved at the maximum armature current and excitation current densities.

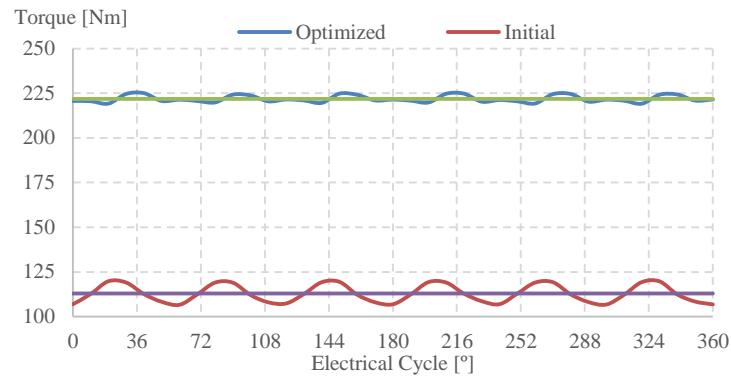

Figure 8. Instantaneous torque characteristics of initial and optimized design

3.4. Torque versus Speed Characteristics

The torque versus speed characteristics of the optimized 12S-14P OR-FEFSM are shown in Figure 9. The graph clearly shows that the final design produced better torque speed ranges and much higher torque capability. From the figure, blue lines indicate the torque curve optimized design while the red lines indicate the initial design torque curve for comparison. Hence, it is noticeable that optimized design achieve maximum torque, 226.9 Nm at base speed 8,081 rpm compared to initial design achieve maximum torque, 112.95 Nm with base speed 4,266rpm. This design have an increment of 89% higher base speed from the initial design. Thus, it shows that the performance of optimized 12S-14P OR-FEFSM is acceptable because it maintained the high torque at a higher speed range and produced higher torque capabilities in high speed region.

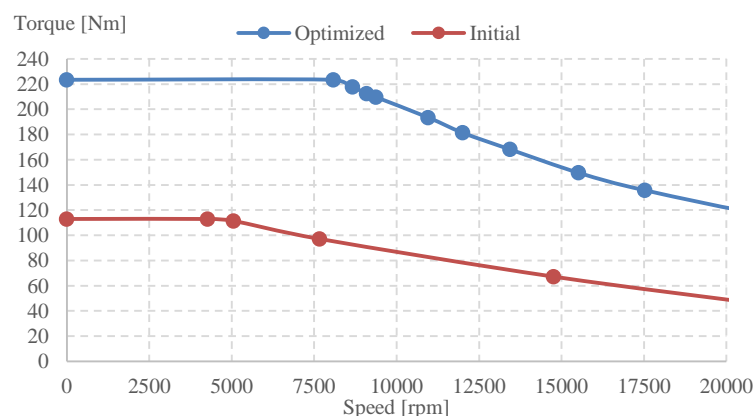

Figure 9. Torque versus Speed characteristics

3.5. Power versus Speed Characteristics

Furthermore, the comparison of power versus speed characteristics is shown in Figure 10. It is clear from the figure that the power achieved by optimized 12S-14P is higher than initial design from 50.46kW increased up to 189 kW followed with base speed initial design, 4,266rpm to 8,081rpm and gradually start

reduced slightly as speed increase. However power starts to reduce slightly when speed is more than 8,081rpm due to iron and copper losses. This power versus speed characteristic curve is the same for initial and optimized design. In addition, the power achieved for initial design at maximum torque of 221Nm is approximately 50.46kW when the speed is 4,266rpm.

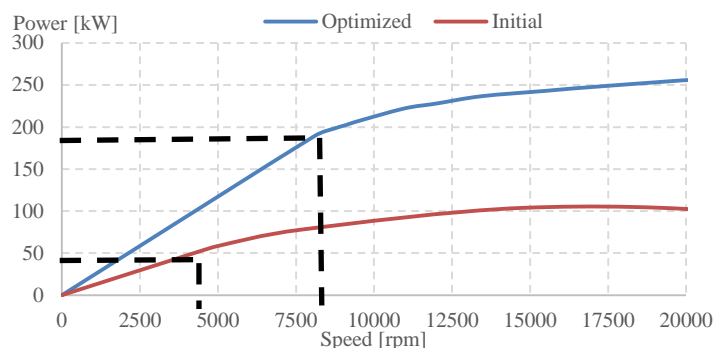

Figure 10. Power versus Speed characteristics

4. CONCLUSION

In design improvement related to 2-Dimension, deterministic method is a reliable and efficient method for 12Slot-14Pole ORFEFSM. As the motor outer diameter remain constant, it still capable to achieve a high torque and more power output of the motor. Compared to initial design performance, the torque has been optimize to reach 221.83 Nm and power output is 189 kW which is higher than the targeted performance. Since 12S-14P ORFEFSM did not have any permanent magnet as excitation, improvement through deterministic method are acceptable. Besides, the improvement is being done successively to achieve optimal results.

ACKNOWLEDGEMENTS

This paper was partly sponsored by the (Geran IGSP, Vot U241) and Centre for Graduate Studies of University Tun Hussein Onn Malaysia (UTHM), Batu Pahat.

REFERENCES

- [1] J. T. Chen and Z. Q. Zhu, "Winding configurations and optimal stator and rotor pole combination of flux-switching PM brushless AC machines," *IEEE Trans. Energy Convers.*, vol/issue: 25(2), pp. 293–302, 2010.
- [2] M. Z. Ahmad, *et al.*, "Optimization of outer-rotor hybrid excitation FSM for in-wheel direct drive electric vehicle," *Mechatronics (ICM)*, 2015 IEEE International Conference on, Nagoya, pp. 691-696, 2015.
- [3] F. Khan, *et al.*, "Coil test analysis of Wound-field three-phase flux switching machine with non-overlapping winding and salient rotor," *Power Engineering and Optimization Conference (PEOCO)*, 2014 IEEE 8th International, Langkawi, pp. 243-247, 2014.
- [4] S. E. Rauch and L. J. Johnson, "Design Principles of Flux-Switch Alternators [includes discussion]," in *Transactions of the American Institute of Electrical Engineers. Part III: Power Apparatus and Systems*, vol/issue: 74(3), 1955.
- [5] W. Fei, *et al.*, "A novel outer-rotor permanent-magnet flux-switching machine for urban electric vehicle propulsion," 2009 3rd Int. Conf. Power Electron. Syst. Appl., 2009.
- [6] Y. Chen, *et al.*, "Three-dimensional lumped-parameter magnetic circuit analysis of single-phase flux-switching permanent-magnet motor," *IEEE Trans. Ind. Appl.*, vol/issue: 44(6), pp. 1701–1710, 2008.
- [7] E. Sulaiman, *et al.*, "A new structure of 12Slot-10Pole field-excitation flux switching synchronous machine for hybrid electric vehicles," *Proc. 2011 14th Eur. Conf. Power Electron. Appl.*, no. dc, pp. 1–10, 2011.
- [8] Z. Q. Zhu, *et al.*, "Analysis of electromagnetic performance of flux-switching permanent-magnet Machines by nonlinear adaptive lumped parameter magnetic circuit model," in *IEEE Transactions on Magnetics*, vol/issue: 41(11), pp. 4277-4287.
- [9] N. A. Rahim, *et al.*, "Design of an In-Wheel Axial Flux Brushless DC Motor for Electric Vehicle," 2006 *International Forum on Strategic Technology*, Ulsan, pp. 16-19, 2006.
- [10] S. M. N. S. Othman, *et al.*, "Rotor pole analysis for 12slot outer-rotor field excitation flux switching motor (ORFEFSM) for electric vehicle," 2015 IEEE Student Conference on Research and Development (SCOReD), Kuala Lumpur, 2015.

- [11] B. M. Song, *et al.*, "Design of an outer-rotor-type permanent magnet motor for electric scooter propulsion systems," 2010 Int. Power Electron. Conf. - ECCE Asia -, IPEC 2010, pp. 2736–2742, 2010.
- [12] C. Liu, "Design of a new outer-rotor flux-controllable vernier PM in-wheel motor drive for electric vehicle," 2011 Int. Conf. Electr. Mach. Syst. ICEMS 2011, 2011.
- [13] S. M. N. S. Othman and E. Sulaiman, "Design study of 3-phase field-excitation flux switching motor with outer-rotor configuration," Power Engineering and Optimization Conference (PEOCO), 2014 IEEE 8th International, Langkawi, pp. 330-334, 2014.
- [14] M. Z. Ahmad, *et al.*, "Analysis of High Torque and Power Densities Outer-Rotor PMFSM with DC Excitation Coil for In-Wheel Direct Drive," *J. Magn.*, vol/issue: 20(3), pp. 265–272, 2015.
- [15] M. K. Hassan, *et al.*, "12Slot-14pole Dual Rotor Hybrid Excitation Flux Switching Machine (DR-HEFSM) load analysis," IEEE Student Conference on Research and Development (SCORED), Kuala Lumpur, pp. 245-249, 2015.
- [16] Z. A. Husin, *et al.*, "Performances comparison of 12S-14P field excitation flux switching motor with overlap and non-overlap windings for hybrid electric vehicles," Research and Development (SCORED), 2014 IEEE Student Conference on, Batu Ferringhi, 2014.
- [17] S.M.N.S. Othman, *et al.*, "Initial Design of 12s-10p and 12s-14p with Outer- Rotor Field-Excitation Flux Switching Machine," 2nd Power and Energy Conversion Symposium, pp. 177–181, 2014.

BIOGRAPHIES OF AUTHORS



Syed Muhammad Naufal Syed Othman was born on 26th of December, 1990 in Johor Bahru, Johor, Malaysia who is currently a PhD scholar at Universiti Tun Hussein Onn Malaysia (UTHM), Johor. Obtained a Bachelor degree and Master degree (Research) in Electrical Engineering in Research Centre for Applied Electromagnetics (EMC) at University Tun Hussein Onn Malaysia in 2013 and 2016. Research interest in electric machine design, niche in flux switching machine for direct drive application.



Md Zarafi Ahmad was born in Batu Pahat, Johor, Malaysia in July, 1979. He is currently PhD scholar at Universiti Tun Hussein Onn Malaysia after obtained his Bachelor degree in Electrical Engineering from University Teknologi Mara in 2003 and Master degree in Electrical Engineering from Universiti Teknologi Malaysia in 2006. He has been a lecturer at Universiti Tun Hussein Onn Malaysia since 2006. His research interests is electric machine design especially in flux switching machine for electric vehicle applications.



Jaudah Abd Rani received the Bachelor of Electrical Engineering with Honours from the Universiti Tun Hussein Onn Malaysia (UTHM), Batu Pahat, Johor in 2016 and is currently working toward the Master degree in Electrical Engineering from UTHM as well. Currently she is a Post Graduate Student under Research Center for Applied Electromagnetics (EMCenter) doing research on Hybrid Flux Switching Motor for Electric Vehicle. She had been working in the field of flux switching machine since 2015. Since then, she had wrote several paper for local conferences regarding hybrid flux switching motor.



Fatihah Shafiqah Bahrim was born in Johor, Malaysia on November 1992. She received the B.S. degree in electrical engineering from Universiti Teknologi Mara (UiTM), Selangor, Malaysia in 2015. Since September 2015, she has been a researcher in Research Center for Applied Electromagnetics (EMC) at Universiti Tun Hussein Onn, Johor, Malaysia. Her present research interests include Design and Modelling of Electrical Machine, Special Electrical Machine and Embedded Power Electronics



Erwan Sulaiman who is currently serving as a senior lecturer at University Tun Hussein Onn Malaysia (UTHM) was born on August 31, 1978 in Johor, Malaysia. He gained his Bachelor degree and Master degrees in Electrical Engineering from University of Malaya in 2001 and 2004. He has been with UTHM from December 2004 and obtained Doctor Degree in Electrical Engineering from Nagoya Institute of Technology (NIT), Japan in 2012. His research interests include design optimizations of HEFISM, WFFSM, in particular, for HEV drive applications.