

## Power Factor Correction with Current Controlled Buck Converter for BLDC Motor Drive

P. Sarala<sup>1</sup>, S. F. Kodad<sup>2</sup>, B. Sarvesh<sup>3</sup>

<sup>1,3</sup>Department of Electrical and Electronics Engineering, JNTUA, Ananthpur, AP, India

<sup>2</sup>Department of Electrical and Electronics Engineering, PESITM, Sivamogga, Karnataka, India

---

### Article Info

#### Article history:

Received Jan 17, 2017

Revised Mar 17, 2017

Accepted Mar 31, 2017

---

#### Keyword:

Brushless DC motor

Buck converter

Commutator

Current control

Power factor

---

### ABSTRACT

Brushless DC motor is a synchronous machine that makes use of electronic commutation instead of mechanical commutator. Brushless DC motors makes use of inverter encompassing static switches for its operation. A simple bridge converter when used for BLDC drive as front end converter makes input source power factor to get reduced which is unacceptable in the power system. To avoid the distortions in the source voltage and source currents, Buck converter which was used as power factor correction (PFC) converter in this paper to improve the power factor. Presence of power electronic converters deteriorates system power factor effecting overall system performance. This paper presents buck converter for power factor correction in brushless DC motor drive system. Buck converter is operated with current control strategy rather to conventional voltage follower control. Simulation model was obtained using MATLAB/SIMULINK software and the brushless DC motor performance characteristics were shown for conditions with different DC link voltages and step variation in DC link voltage. Total harmonic distortion in source current was also presented.

Copyright © 2017 Institute of Advanced Engineering and Science.  
All rights reserved.

---

### Corresponding Author:

P. Sarala,

Department of Electrical and Electronics Engineering,

JNTUA, Ananthpur, Andhra Pradesh, India.

Email: dilip1.eee@gmail.com

---

## 1. INTRODUCTION

Technology is for human convenience and innovation of electric motors gave scope to reduce the efforts put in by human mankind in many applications especially in industries. Electric motor is an electro-mechanical device which converts electrical energy to mechanical energy. Motors can be broadly classified in to DC type and AC type of motors. DC motor exhibits fine speed characteristic which are very much a constraint in many of the applications. DC motors are simple in construction and has good torque characteristics. Commutation is done with the help of brush-commutator assembly. Brush is a static device which collects current from or in to machine via commutator. Commutator is a rotating device which transforms supplied DC to alternating type to armature. Due to the presence of commutator and brush assembly in conventional DC motors, additional losses are produced and with resulting sparks. This phenomenon affects the overall system efficiency. To improve the system efficiency and to reduce additional losses produced due to brush-commutator assembly, brushless DC motors are developed constructed without the need of brushes and commutator for commutation [1]-[3].

Brushless DC (BLDC) motors are synchronous motors developed eliminating brush-commutator assembly. BLDC motor is constructed with armature on its stator and permanent magnets on its rotor [4]-[5]. BLDC motor does not consist of windings on both stator and rotor thus consuming less copper and less reactive power absorption as compared with induction motor which has windings on both stator and rotor. Solid state electronic switches carries electrical commutation in BLDC motor excluding the use of brush-

commutator assembly as in conventional DC motors. This type of construction can improve system efficiency with increased performance. Stator windings of BLDC motor are excited with alternating three-phase currents producing rotating magnetic field. Rotating magnetic field interacts with the rotor flux and torque is exerted on rotor. BLDC motor can run at high speeds with low acoustic noise. High efficiency and reliability also makes BLDC motor a better choice for many applications [6]-[7].

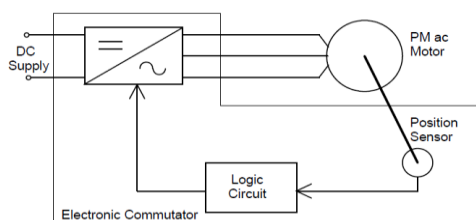

Figure 1. Typical BLDC motor

Typical BLDC motor is shown in Figure 1. BLDC motor consists of front-end converter which converts given DC supply to AC. Though name suggests it is DC motor but in operation it is a synchronous motor. After conversion of DC to AC, phase windings are excited and thus motor rotates with the principle of electro-magnetic induction.

In operation, the supplied AC will be converted to DC (since general available supply will be of AC type) and again in front end converter, DC is converted to AC when BLDC is connected to main supply system. Presence of front-end converter for BLDC motor which is typically a power electronic converter draws non-linear components of source currents and induces harmonic components in source components [8]. This phenomenon of inducing harmonics in source components and reduces the power factor of the system and reduces the system efficiency and performance. This property in BLDC insists for power factor correction.

Many control strategies were proposed [9]-[12] and this paper presents a current controlled buck converter for power factor correction in BLDC drive system. This power factor correction [13]-[15] control is based on current follower. Rotor speed and positions were sensed and are used for current control. Static switch in buck converter is operated from control strategy and power factor in the system was corrected. A total harmonic distortion for the system was presented for different cases. Control strategy was tested for conditions of different DC link voltages and step-change in DC link. BLDC motor characteristics were also shown for different cases.

## 2. BLDC MOTOR WITH BUCK CONVERTER

Generally the available supply is AC and for a BLDC motor to operate needs DC. For this conversion of AC to DC, a diode bridge rectifier is used. Diode bridge rectifier converts AC to DC and the DC output is fed to buck converter. Buck converter is DC-DC converter which is typically a step-down converter. A high voltage DC is stepped down to low voltage DC using a buck converter. Obtained low voltage DC is fed to inverter which is voltage source converter through a filter and DC link from capacitor. Inverter produces three phase output and the stator windings of BLDC motor are excited. When stator windings are excited rotating magnetic field is produced and due to interaction of stator and rotor fields. Torque is exerted on rotor. The rotor position is continuously sensed by sensors and sent to electronic commutation which triggers static switches of voltage source converter (front-end converter for BLDC). Due to the presence of diode bridge rectifier for conversion of AC to DC, harmonics are induced in to the system which needs corrective measures for optimal system performance.

## 3. POWER FACTOR CORRECTION WITH BUCK CONVERTER FOR BLDC MOTOR

For conversion of available AC supply to DC, a diode bridge rectifier is used. Presence of non-linear devices connected to the system induces harmonics in to the source components as they draw non-linear components. This injection of harmonics or presence of harmonics in source components affects the performance of the system reducing efficiency. Power factor is mainly affected due to presence of harmonics and increases the system losses. BLDC motor with power factor correction is shown in Figure 3. The rectified output from AC converting to DC is fed to buck converter where power factor correction takes

place. Power factor correction is done by proper switching of static switch in buck converter. Switching signals were obtained from the control circuit output.

Speed reference is taken and is converted to voltage signal. Obtained reference voltage is compared with actual DC link voltage and error signal is sent to PI controller for error reduction obtaining current magnitude. From source voltage, information regarding sine is obtained and combined to current magnitude obtaining reference current signal. The obtained reference current signal is compared to actual current and error signal is sent to hysteresis current controller which produces gating pulses to buck converter.

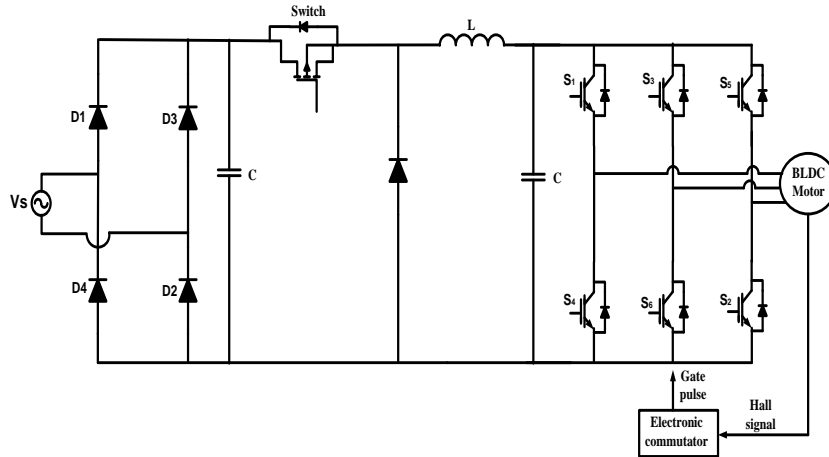

Figure 2. BLDC motor with Buck converter without control

#### 4. RESULTS AND ANALYSIS

In this section, the results were discussed for different cases considering different DC link voltages of 150V, 200V and also for step variation in DC link voltage.

##### 4.1. Analysis for Vdc = 150V

Figure 4 shows the source voltage and current of system with DC link voltage of 150V. DC link voltage maintained at 150V was shown in Figure 5. Speed of BLDC motor when DC link voltage is maintained at 150V was shown in Figure 6, indicates motor running at constant speed of 1400 RPM. Figure 7 shows torque of BLDC motor and torque fluctuation is maintained low. Stator current drawn by BLDC motor was shown in Figure 8. Power factor of the system is shown in Figure 9 and is maintained nearer to unity as can be observed since there is no phase shift between source voltage and current waveforms. Total harmonic distortion in source current was shown in Figure 10 indicating THD as 1.88% which is nominal value below 5%. Thus power factor is maintained in system with power factor correction converter which can be concluded from power factor and harmonic distortion shown.

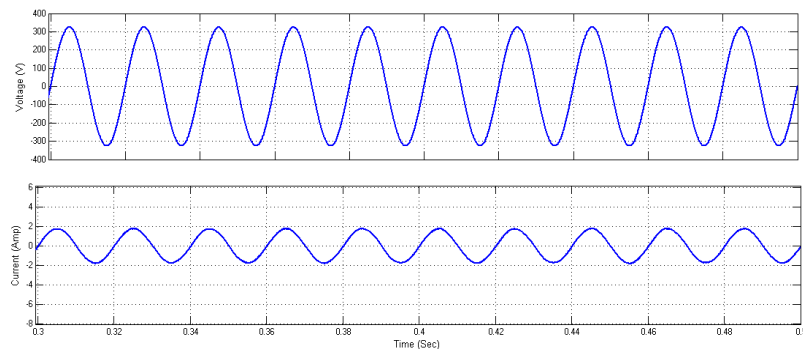

Figure 4. Source voltage and source current of system

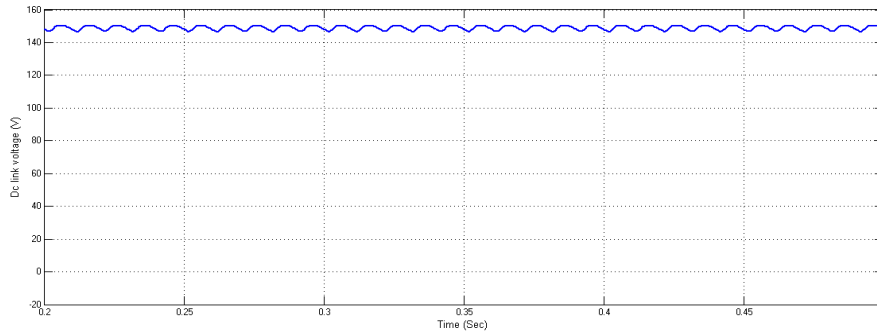

Figure 5. DC link voltage of system

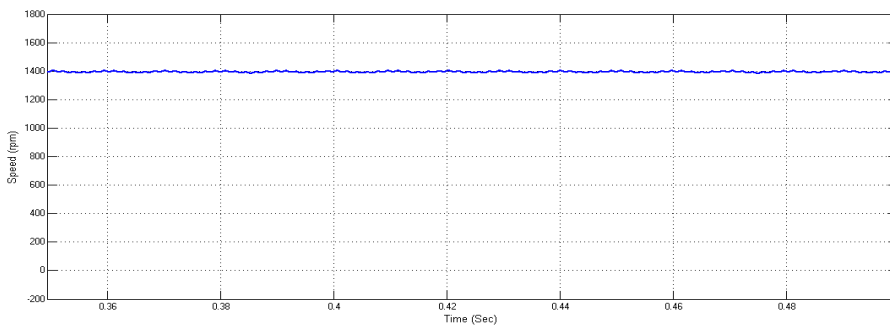

Figure 6. Speed of BLDC motor

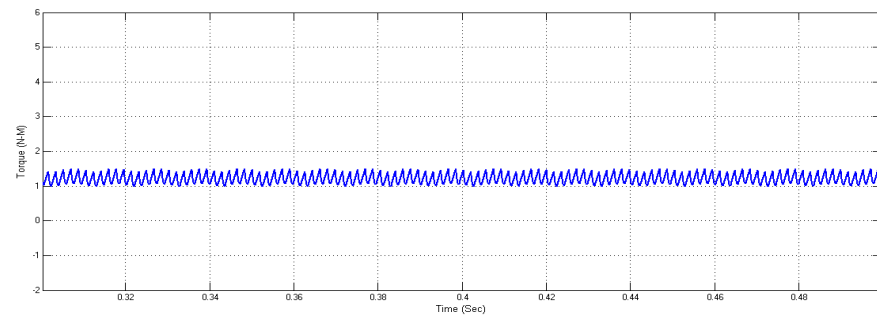

Figure 7. Torque of BLDC motor

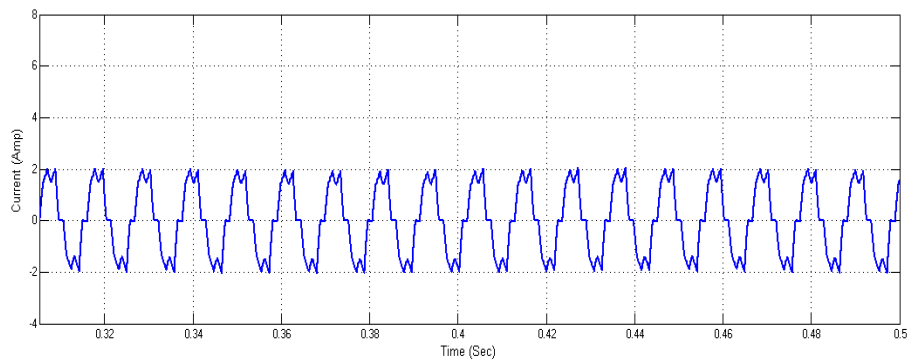

Figure 8. Stator current of BLDC motor

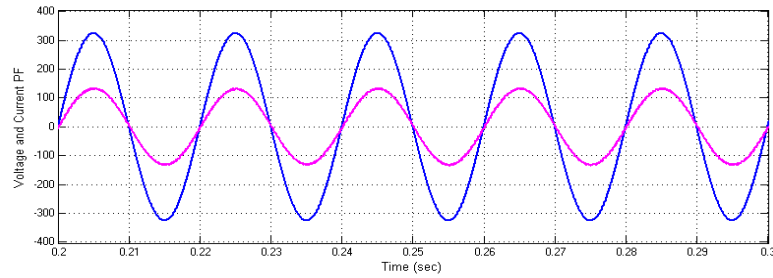

Figure 9. Power factor of system

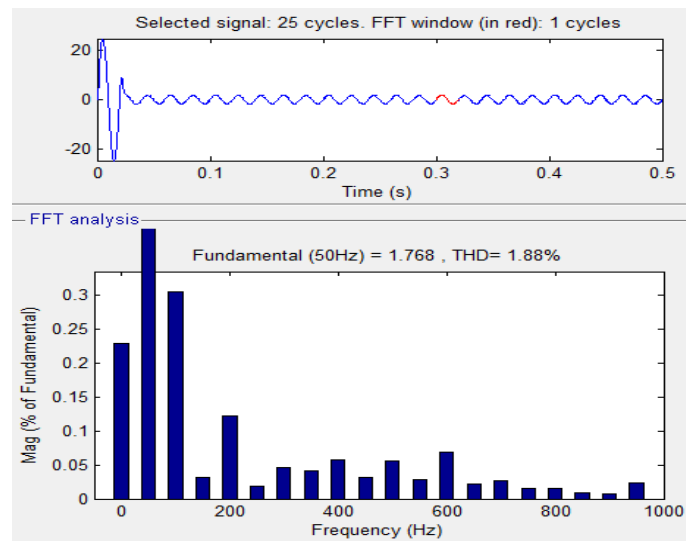

Figure 10. THD in source current

#### 4.2. Analysis for $V_{dc} = 200V$

Figure 11 shows the source voltage and current of system with DC link voltage of 200V. DC link voltage maintained at 200V was shown in Figure 12. Speed of BLDC motor when DC link voltage is maintained at 200V was shown in Figure 13, indicates motor running at constant speed of 1900 RPM. Figure 14 shows torque of BLDC motor and torque fluctuation is maintained low. Stator current drawn by BLDC motor was shown in Figure 15. Power factor of the system is shown in Figure 16 and is maintained nearer to unity as can be observed since there is no phase shift between source voltage and current waveforms. Total harmonic distortion in source current was shown in Figure 17 indicating THD as 1.44% which is nominal value below 5%. Thus power factor is maintained in system with power factor correction converter which can be concluded from power factor and harmonic distortion shown.

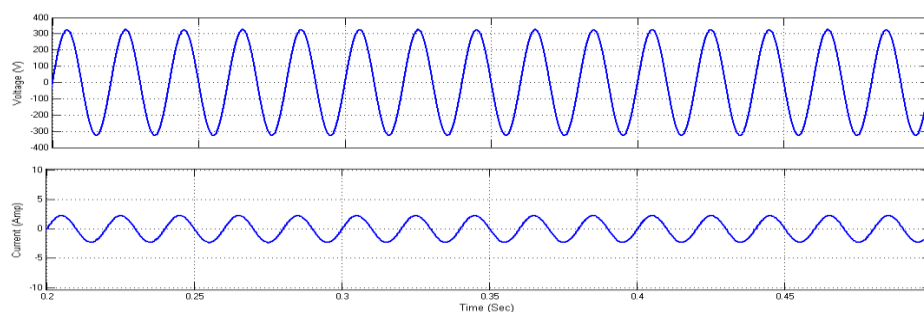

Figure 11. Source voltage and source current of system

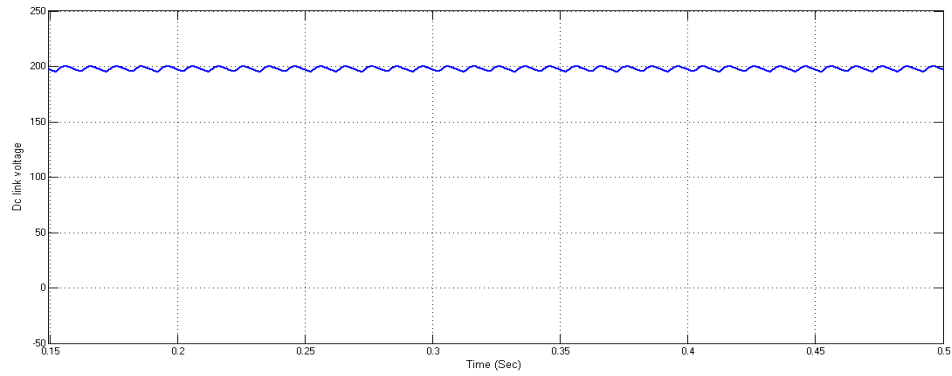

Figure 12. DC link voltage of system

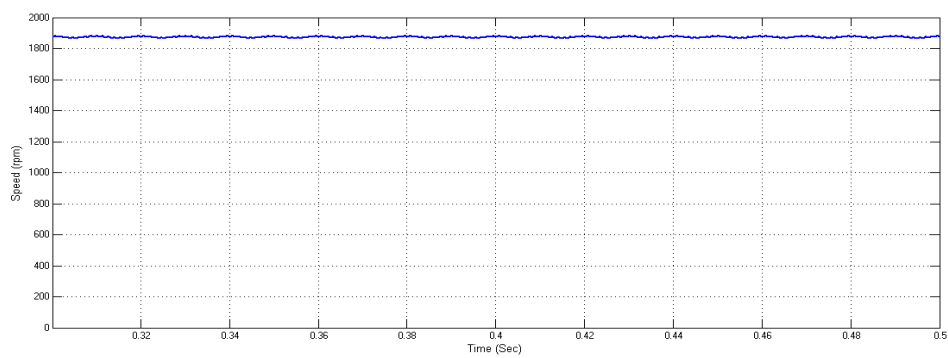

Figure 13. Speed of BLDC motor

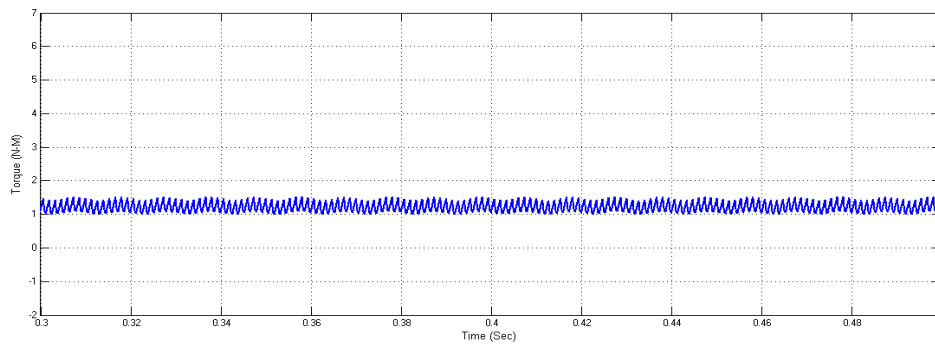

Figure 14. Torque of BLDC motor

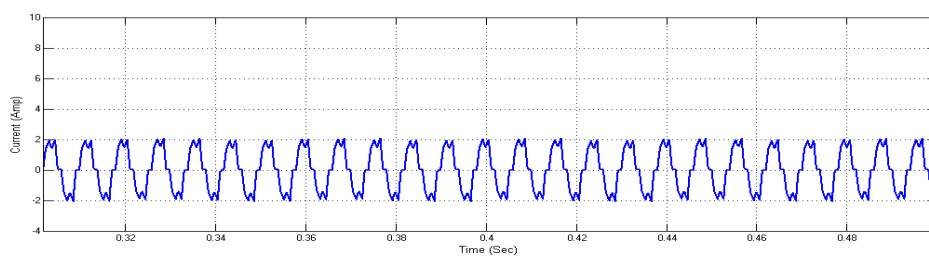

Figure 15. Stator current of BLDC motor

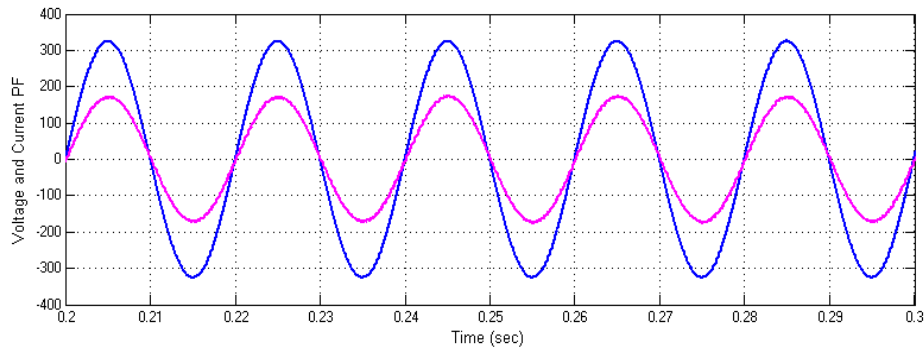

Figure 16. Power factor of system

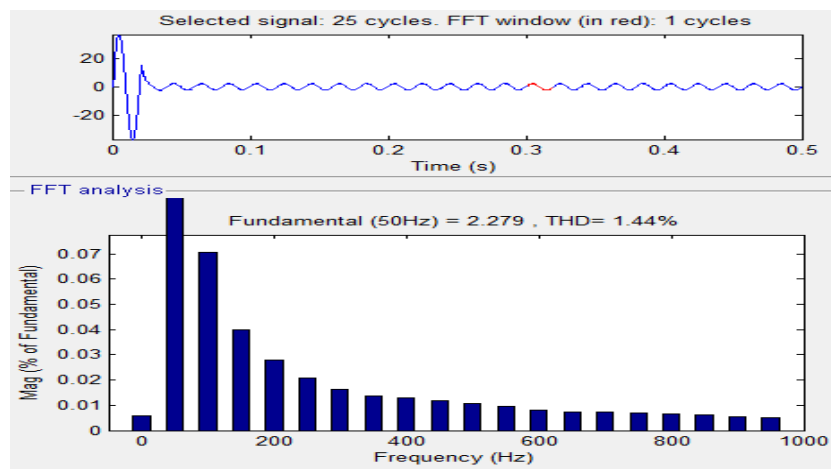

Figure 17. THD in source current

#### 4.3. Analysis for Step Change in Vdc

Figure 18 shows the source voltage and current of system with step variation in DC link voltage. DC link voltage step variation was shown in Figure 19 where step variation in DC link voltage can be observed at 0.3 sec. Speed of BLDC motor when DC link voltage is step varied was shown in Figure 20. Speed of the motor is constant till 0.3 sec and after step variation in DC link voltage speed of the motor is also varied. Figure 21 shows torque of BLDC motor and torque fluctuation is maintained low. Stator current drawn by BLDC motor was shown in Figure 22. Power factor of the system is shown in Figure 23 and is maintained nearer to unity as can be observed since there is no phase shift between source voltage and current waveforms. Thus power factor is maintained in system with power factor correction converter which can be concluded from power factor shown.

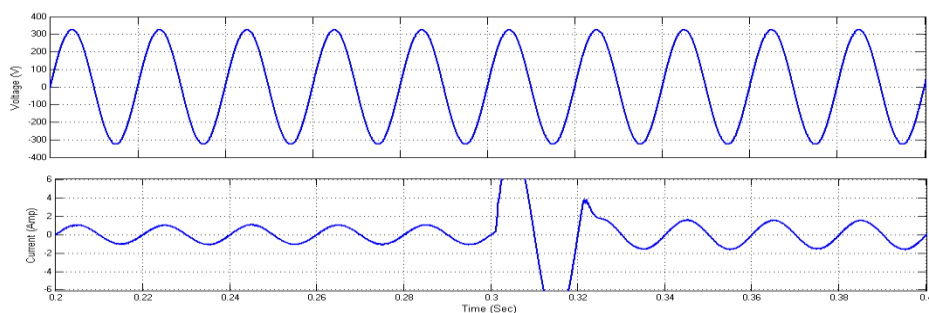

Figure 18. Source voltage and source current of system

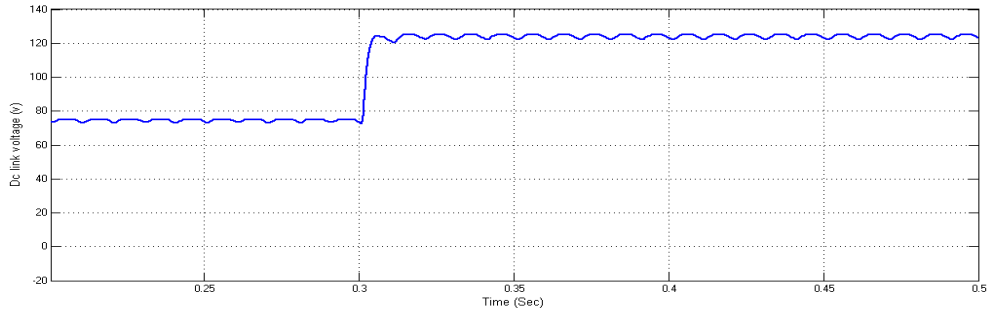

Figure 19. DC link voltage of system

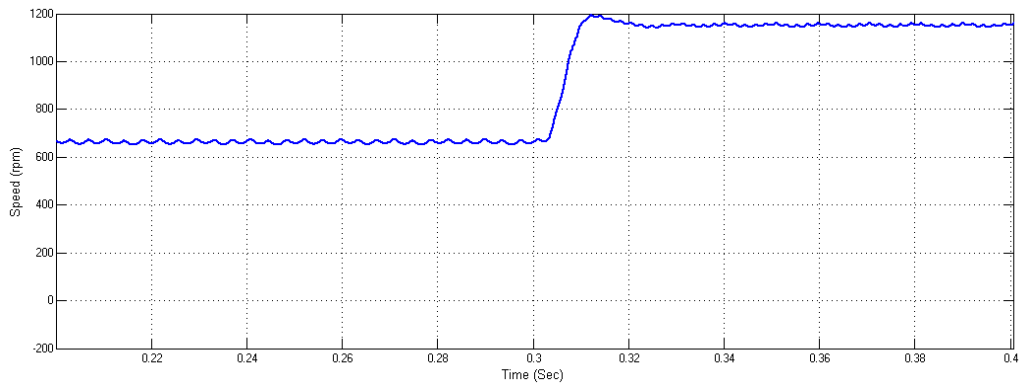

Figure 20. Speed of BLDC motor

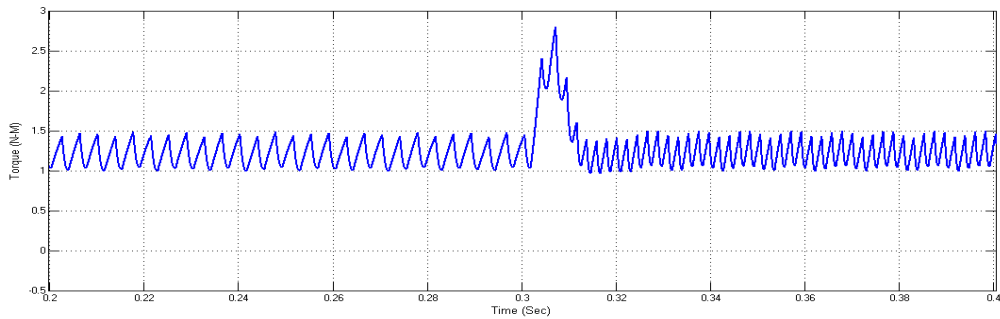

Figure 21. Torque of BLDC motor

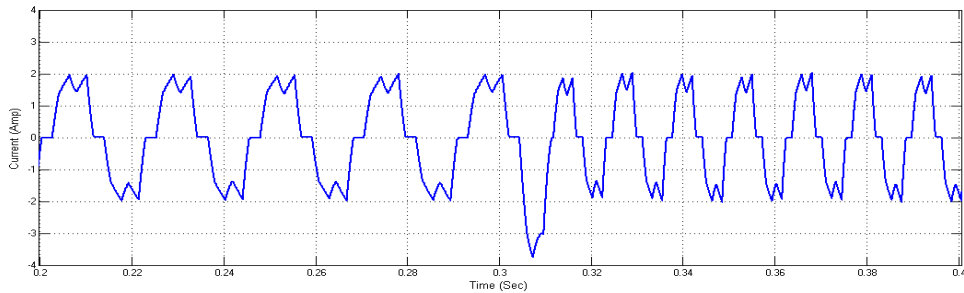

Figure 22. Stator current of BLDC motor



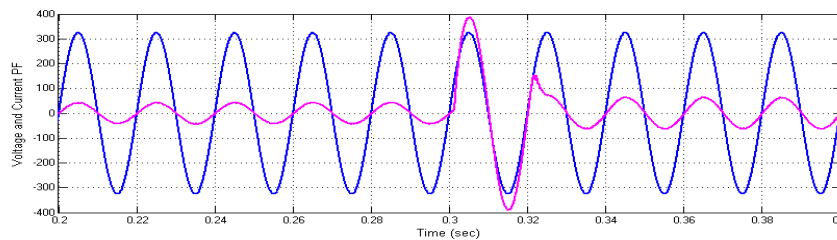

Figure 23. Power factor of system

## 5. CONCLUSION

Brush and commutator assembly in conventional DC motors gives additional losses which reduces the system efficiency with additional losses and wear and tear. Elimination of brush and commutator for electric commutation can improve system performance. Brushless DC (BLDC) motors constructed without presence of mechanical commutator and brushes can give better performance with enhanced efficiency making use of electronic commutation. Use of front-end converters for conversion of power from one form to other for operation of BLDC motor induces harmonics in to the system deteriorating power factor. Power factor correction in the system was done using a buck converter controlled with current control technique. Implication of current control strategy with buck converter for power factor correction was found suitable and was tested for different DC link voltages and also for step variation in DC link voltage. Buck converter with current control strategy was explained. Total harmonic distortion in source current was kept within normal limit and was shown. Power factor for different cases was maintained nearer to unity as no phase shift between source current and voltage was observed from shown results. Current controlled buck converter can improve power factor of the system which is very essential in any system.

## REFERENCES

- [1] Pillay and P. Freere, "Literature survey of permanent magnet ac motors and drives," in *Proc. IEEE IAS Rec.*, 1989, pp. 74–84.
- [2] A. Halvaei Niasar, "Sensorless control of four switch, threephase brushless DC motor drives for low-cost applications," Ph.D. dissertation, Dept. Electr. Eng., Iran Univ. Sci. Technol., Tehran, Iran, Dec. 2007.
- [3] CW. Lu, "Torque Controller for Brushless DC motors", *IEEE Transactions on Industrial Electronics*, vol. 46, pp. 471–473, 1999.
- [4] Ashwini M. Welekar and A. A. Apte, "Development of Brushless DC Motor Drive," *Journal of Electrical and Electronics Engineering (ICAET-2014)*, PP 12-18, 2014.
- [5] R. K. Dasari, S. J. Madipalli and S. Javvadi, "Power quality improvement of brushless permanent magnet and non-permanent magnet machines using DSTACOM," *2015 International Conference on Electrical, Electronics, Signals, Communication and Optimization (EESCO)*, Visakhapatnam, 2015, pp. 1-6.
- [6] KJ. Kang, et al., "Development of a highly efficient brushless dc motor utilizing both radial and axial air gaps", *Journal of Applied Physics*, vol. 111, 2012.
- [7] Nitin Sanadhya et al., "Reliability of Permanent Magnet Brushless D.C. Drives Using IGBT's," *International Journal of Innovative Research in Science, Engineering and Technology*, Vol. 2, Issue 3, March 2013.
- [8] NAG, Tridibesh et al. "An efficiency optimization scheme for BLDC motor drive system," *International Journal of Power Electronics and Drive Systems (IJPEDS)*, v. 6, n. 4, p. 869-875, dec. 2015.
- [9] Chandra Rao et al., "Power Factor Correction in Two Leg Inverter Fed BLDC Drive Using Cuk Dc-Dc Converter," *International Journal of Power Electronics and Drive Systems (IJPEDS)*, v. 6, n. 2, p. 196-204, jun. 2015.
- [10] Srinivasan, K. et al. "Power Quality Analysis of Vienna Rectifier for BLDC motor Drive Application," *International Journal of Power Electronics and Drive Systems (IJPEDS)*, v.7, n.1, p.7-16, mar. 2016.
- [11] T. Sutikno, et al., "FPGA based a PWM Technique for Permanent Magnet AC Motor Drives", *International Journal of Reconfigurable and Embedded Systems*, vol. 1, pp. 43-48, 2012.
- [12] P. Agrawal, et al., "Comparative Study of Fuzzy Logic Based Speed Control of Multilevel Inverter fed Brushless DC Motor Drive", *International Journal of Power Electronics and Drive System*, vol. 4, 2014.
- [13] Bogimi Sirisha, "Three Phase Two Leg Neutral Point Clamped Converter with output DC Voltage Regulation and Input Power Factor Correction," *International Journal of Power Electronics and Drive Systems (IJPEDS)*, Vol 2 No 2, 2012 pages 138-150.
- [14] R. Balamurugan, "An Approach of Power Factor Correction in BLDC Motor Drives Using Cuk Derived Converters," *TELKOMNIKA Indonesian Journal of Electrical Engineering*, Vol 12 No 12, 2014 pages 8092-8097.
- [15] A. Purna Chandra Rao, "Power Factor Correction in Two Leg Inverter Fed BLDC Drive Using Cuk DcDc Converter," *International Journal of Power Electronics and Drive Systems (IJPEDS)*, Vol 6 No 2, 2015 pages 196-204.