

## Multicarrier-SPWM Based Novel 7-Level Inverter Topology with Photovoltaic System

R. Palanisamy<sup>1</sup>, V. Sinmayee<sup>2</sup>, K. Selvakumar<sup>3</sup>, K. Vijayakumar<sup>4</sup>

Department of Electrical and Electronics Engineering, SRM University, Chennai, India

---

### Article Info

#### Article history:

Received Jan 3, 2017

Revised Mar 3, 2017

Accepted Mar 17, 2017

---

#### Keyword:

DsPIC controller

Multicarrier sinusoidal pulse width modulation (MCSPWM)

Multilevel inverter

PV system

---

### ABSTRACT

In this paper a novel 5 switch seven level DC-AC inverter is being proposed. The proposed multilevel inverter uses reduced number of switches as compared to the switches used in the conventional multilevel inverter. The inverter has been designed to generate a 7 level AC output using 5 switches. The voltage stress on each of the switches as well as the switching losses is found to be less, minimized common mode voltage (CMV) level and reduced total harmonic distortion. The proposed 7-level inverter topology has four dc sources, which is energized through the PV system. Proposed inverter is controlled with help of multicarrier sinusoidal pulse width modulation (MCSPWM). The simulation and hardware results were verified using matlab simulink and dspic microcontroller respectively.

Copyright © 2017 Institute of Advanced Engineering and Science.  
All rights reserved.

---

### Corresponding Author:

R. Palanisamy,

Department of Electrical and Electronics Engineering,

SRM University, Kattankulathur, Chennai, India.

Email: krsalani@gmail.com

---

## 1. INTRODUCTION

With the advent of increasing pollution levels and depleting natural resources, it is evident that non renewable energy sources such as coal cannot be used for the longer run. So the solution for the future is non-conventional energy sources such as wind energy, solar energy etc [1]. Photovoltaic energy which is the best form of energy available to us in the form of sunlight. The energy received from the sun can be used in solar heating applications as well as utilizing the solar energy to produce the electricity [2]. The solar energy is the best form as it causes no pollution, It is available free of cost and it requires very less maintenance as compared to the other energy sources. The only problem that lies in the grid connected PV systems is that they compromise the power quality, Rapid changes in the voltage between the PV array and the grid results in voltage imbalance and voltage flicker [3]. To solve the problem of leakage current and maintaining the power quality is to use transformer-less multilevel inverters. The benefits of the transformer-less multilevel inverters in grid connected systems are that it increases the system stability and reduces the current leakage and reduces the total harmonic distortion. The benefit of the transformer less system is overall weight size and cost reduction [4]-[5].

The multilevel inverter is used in application pertaining from medium voltage levels to higher voltage levels. The advantages lie in reduced DV/DT stress on each of the switches to the increase in the voltage levels, reduced harmonics and lower switching losses and less electromagnetic interference [6]-[7]. As in all the conventional multilevel inverters such as NPCMLI, H-BRIDGE, Diode clamped multilevel inverter the active sources of energy is higher and the switches used in the conventional multilevel inverters is  $2(n-1)$ ; where n is the no. of output voltage [8]. So as the voltage level increases the no of switches also increases, with the increase in the number of switches the cost of the entire system increases [9].

Multicarrier sinusoidal pulse width modulation is being used here for the purpose of generating the pulses. In multicarrier sinusoidal pulse width modulation technique 2 or more carrier waves are compared with a reference sinusoidal wave and the pulse is generated using appropriate timing [10]. The generated pulse is used to trigger the MOSFET. In comparison with the other proposed topologies such as diode clamped multilevel inverter uses 12 switches, 10 diodes, 6 input capacitors to produce a 7 level output, Clamped capacitor multilevel inverter uses 12 switches, 5 clamped capacitors and 2 input capacitors [11]. In [12] paper uses 8 switches, 3 diodes and 3 input capacitors, as our proposed system uses no diodes and active elements and our system contains less number of switches as a result the cost of our entire system reduces.

In this proposed system the inverter topology has been designed to generate a 7 level AC output using 5 switches. The voltage stress on each of the switches as well as the switching losses is found to be less, minimized CMV level and reduced total harmonic distortion. The proposed 7-level inverter topology has four dc sources, which is energized through the PV system. Proposed inverter is controlled with help of multicarrier sinusoidal pulse width modulation (MCSPWM), which briefly discussed in the following sections.

## 2. PV PANEL MODELLING AND BOOST CONVERTER

The important part of the solar panel is the solar cell. A photovoltaic panel is designed by connecting any such solar cells in either parallel or series depending upon the maximum power that has to be utilized. The characteristic equation of the PV is dependent upon the number of solar cells either in series or in parallel. The current variation is less dependent on the shunt resistance and it is more dependent on the series resistance. It operates as a constant current source at less voltage and a constant voltage source at less current.

### 2.1. Solar Irradiation

The PV-IV curves of the solar cell are highly dependent on the solar irradiation. The solar irradiance is the amount of the solar energy received from the sun. The maximum power that can be extracted from the solar cell depends on the irradiance. The higher the amount of solar irradiance the maximum will be the power input and therefore the maximum will be the magnitude of power generated. With increase in the solar irradiation the open circuit voltage increases. When the amount of the sunlight increases the solar excitation also increases as a result of which the electrons get excited and the electron mobility increases and the maximum power generated also increases.

### 2.2. Effect of Variation in Temperature

With the increase in the temperature solar cell efficiency reduces, as the increase in the temperature is accompanied by the decrease in the open circuit voltage. The increase in the band gap also increases the band gap barrier and it requires a lot of excitation for crossing the band gap, so the efficiency reduces.

### 2.3. Boost Converter

The boost converter is used to step up the input voltage which it receives from the solar cell; The main components are inductor, diode and a high frequency switch. It is used to supply power to the load at a voltage higher than the input voltage. There are two modes of operation 1) Charging mode 2) Discharging mode.

- a. Charging mode: When the switch is closed the inductor charging takes place through the switch. The charging current is exponential in nature. The diode restricts flow of the current from source to the load and demand of the load is met by discharging of the capacitor.
- b. Discharging mode: The switch is open in this mode, the inductor discharging takes place and together with the source charges the capacitors and meets the load demands.

### 2.4. Maximum Power Point Tracking

The MPPT is the electronic device which helps the PV panel to extract the maximum power from the solar cell. It varies the electrical operating point of the modules so as to increase the output of the PV modules. A typical solar panel converts only about 30 percent to 40 percent of the solar irradiance as a result of which the efficiency reduces. According to the maximum power transfer theorem for maximum power to be extracted the load impedance should match with the thevenin impedance. In the source side a boost converter is connected in order to increase the output voltage as a result of which by changing the duty cycle of the switching, we can match the load side impedance with the source side impedance. The different

control strategies used in the MPPT converter are perturb and observe, fuzzy logic control and fractional short circuit current.

### 3. POWER STAGE

#### 3.1. Circuit Configuration

The proposed seven level 5 switch inverter topology is shown in Figure 1. Shows the proposed novel topology producing the 7 level output. The input voltage is given by the 4 individual PV system panels. The pulses are given to each of the 5 MOSFETS controlled switches. The output generated is a 7 level staircase output which nearly identifies itself with the sine wave.

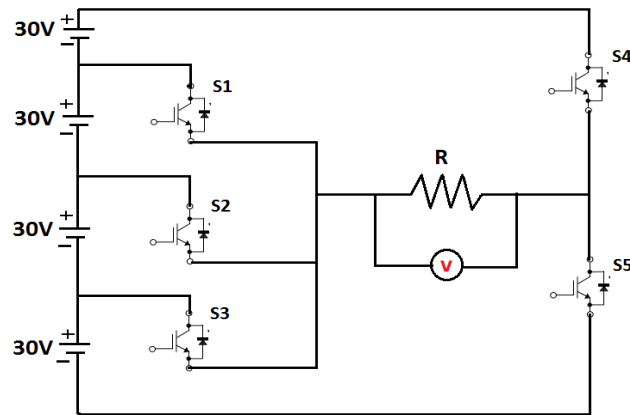

Figure 1. Novel 7 Level 5switch inverter topology

#### 3.2. Modes of Operation

The required 7 level output voltage level (+30V, +60V, +90V, 0V, -30V, -60V, -90V) are generated as follows :

- Mode 1 : To generate +30v voltage level, switches S1 and S4 are turned on and remaining switches are turned off. Figure 2.1 (a) shows the flow of current for model1.
- Mode 2 : To generate +60v voltage level, switches S2 and S4 are turned on and remaining switches are turned off. Figure 2.1(b) shows the flow of current for mode2.
- Mode 3 : To generate +90v voltage level, switches S3 and S4 are turned on and remaining switches are turned off. Figure 2.1(c) shows the flow of current for mode3.
- Mode 4 : To generate 0v voltage level, switches S4 and S5 are turned on and remaining switches are turned off. Figure. 2.1(d) shows the flow of current for mode 4.
- Mode 5 : To generate -30v voltage level, switches S3 and S5 are turned on and remaining switches are turned off. Figure 2.1(e). shows the flow of current for mode 5.
- Mode 6 : To generate -60v voltage level, switches S2 and S5 are turned on and remaining switches are turned off. Figure 2.1(f). shows the flow of current for mode 6.
- Mode 7 : To generate -90v voltage level, switches S1 and S5 are turned on and remaining switches are turned off. Figure 2.1(g). shows the flow of current for mode 7.

The modes of operation for generation of proposed 7-level output voltage are shown in Table 1.

Table 1. Switching Combination Required to Generate the Seven-Level Output Voltage Waveform

Modes	Switches					Output Voltage (V)
	S1	S2	S3	S4	S5	
Mode 1	ON	OFF	OFF	ON	OFF	+30
Mode 2	OFF	ON	OFF	ON	OFF	+60
Mode 3	OFF	OFF	ON	ON	OFF	+90
Mode 4	OFF	OFF	OFF	OFF	OFF	0
Mode 5	OFF	OFF	ON	OFF	ON	-30
Mode 6	OFF	ON	OFF	OFF	ON	-60
Mode 7	ON	OFF	OFF	OFF	ON	-90

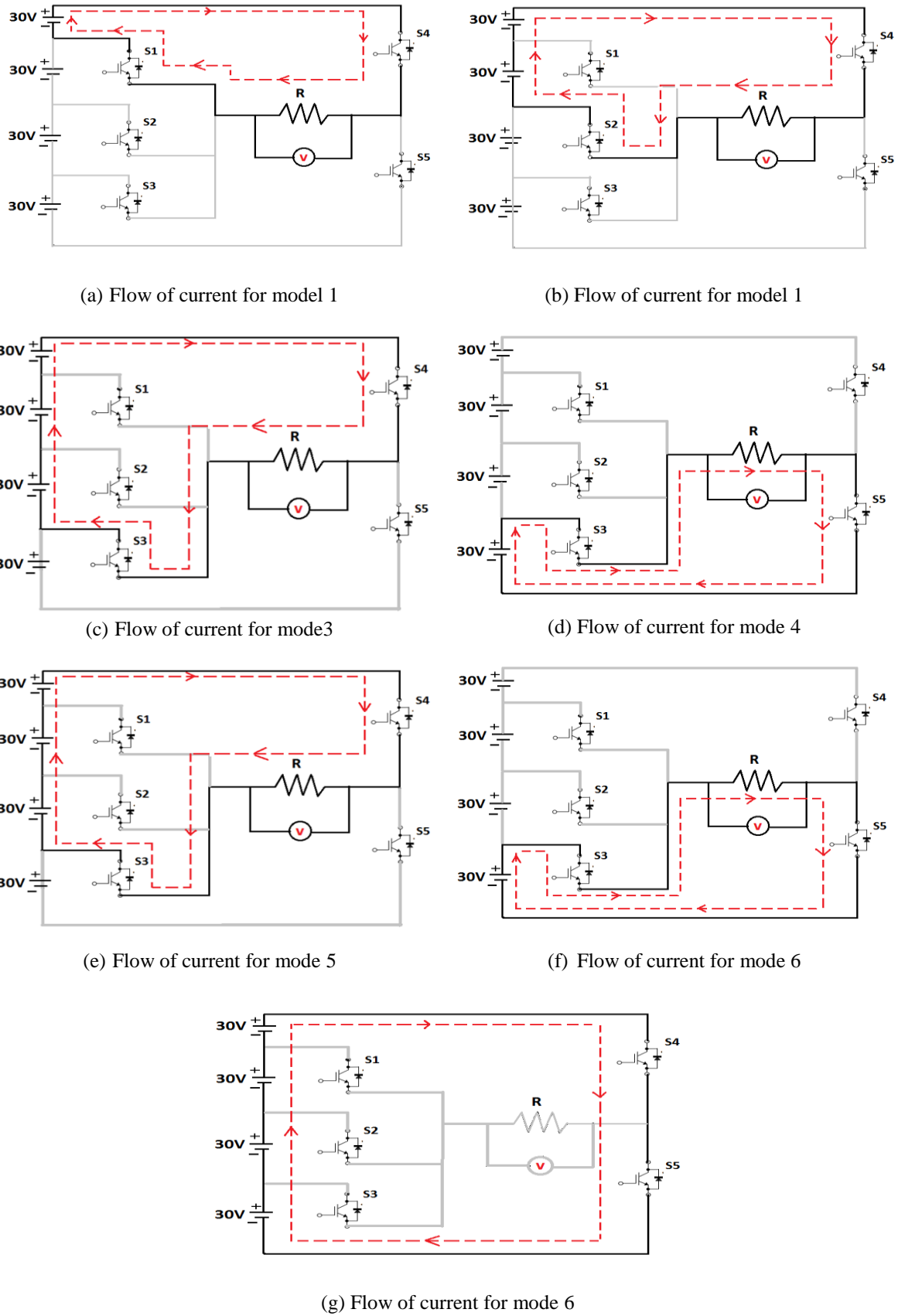

Figure 2. Modes of operation (a) mode1= +30 V (b) mode2= +60 V (c) mode3= +90 V (d) mode4= -30 V (e) mode5= -60 V (f) mode6= -90 V (g) mode7= 0 V

#### 4. MULTICARRIER SPWM (MCSPWM)

In order to preserve or reduce system cost or structure, imperative to maintain the shoot through ratio as constant. At the same to reduce the voltage stress across the power switches, the boosted voltage with proper variation of modulation index. In Figure 3 shows the multicarrier sinusoidal pulse width modulation scheme, which acquire better voltage gain with constant value of shoot through state. Based on the MBC control, the z-source inverter operated either on upper shoot through or lower shoot through mode. Constant boost ratio of the proposed system defined as,

$$B = \frac{\pi}{[3\text{sqr}(3)M]-\pi} \quad (1)$$

Where the B is boost ratio & M is modulation index. And the ripple content in the inductor is,

$$\epsilon L_1 = \frac{V * K}{2 * \pi * 6 * f * L} \quad (2)$$

Here V is applied voltage, K-constant, f-frequency, L- design value inductance

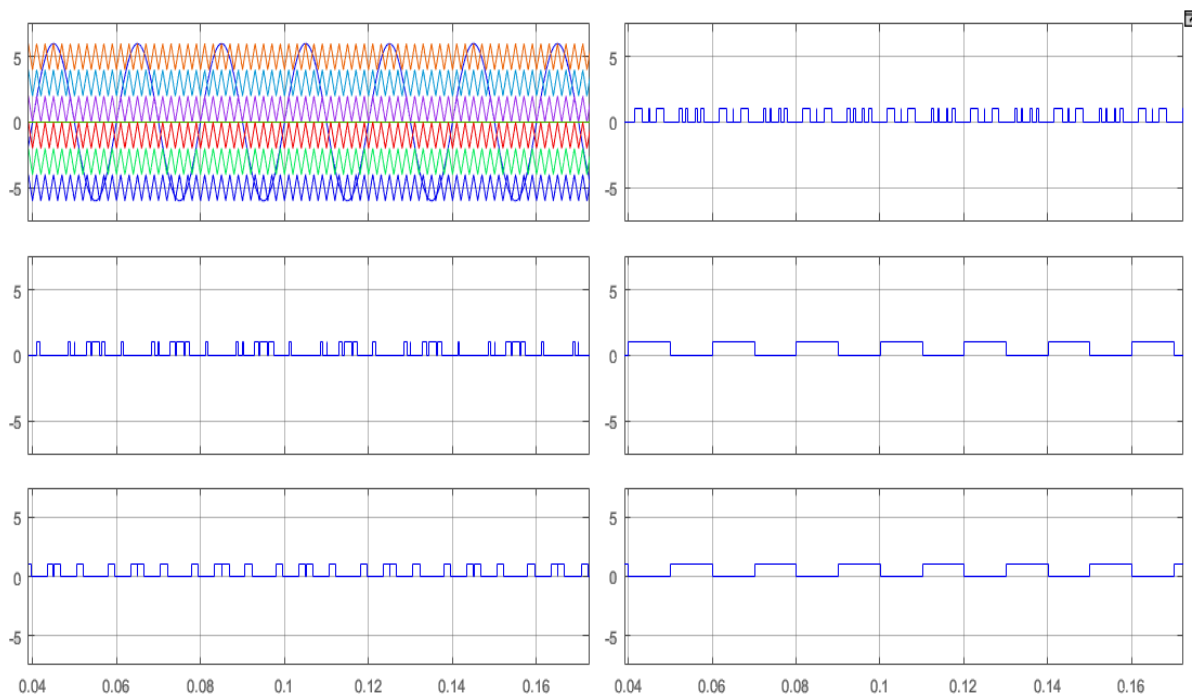

Figure 3. Multicarrier sinusoidal PWM scheme

A triangle carrier wave is evaluated with a three phase reference sine wave, each phase for a positive side switch shoot through state occurs every time the triangle peak value overshoots the sinusoidal peak amplitude, so twice for each phase in one cycle of operation. At other instants when the sinusoidal magnitude is greater, the inverter exhibits active vector switching states. Using minimum /maximum utility for the three phase sinusoidal its upper and lower wrapper waveforms are compared alongside the same carrier to engender shoot through pulses for the positive and negative carrier peak values respectively, which added using OR gate circuit.

#### 5. SIMULATION AND RESULTS

To verify the performance of 7-level proposed inverter novel topology was simulated using matlab16. The IGBT control switches are prepared for this novel proposed 7-level 5 switch inverter, which is controlled by multicarrier sinusoidal pulse width modulation technique. The simulation of novel 7-level inverter topology is shown in Figure 4.

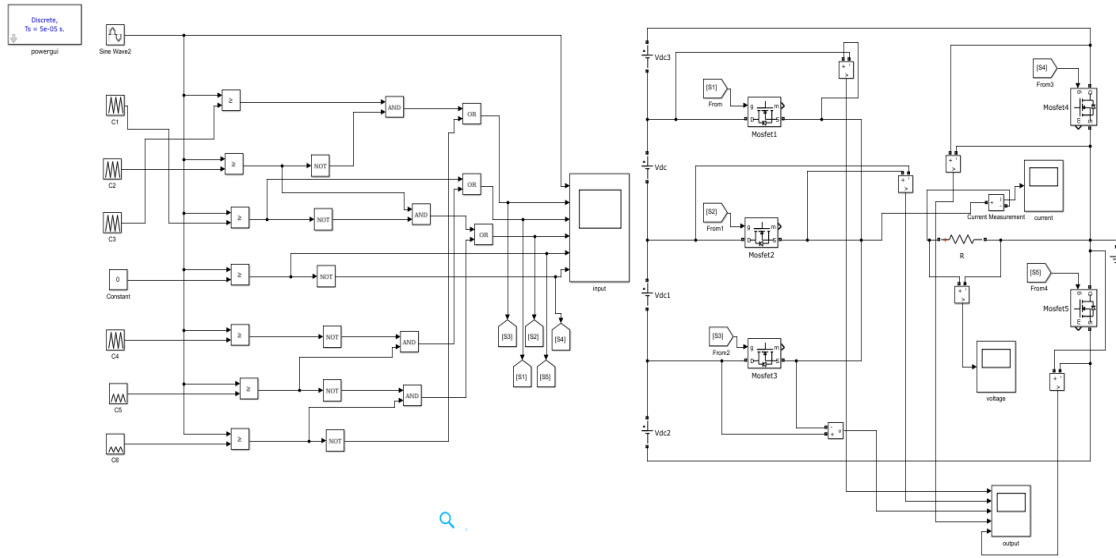

Figure 4. Simulation diagram of proposed system 7-level inverter

In Figure 5 shows the 7-level stepped output voltage of proposed system inverter with voltage of 292 V and the output current of 9.7A, which is shown in Figure 6 and in Figure 7 shows the switching pulses generation with help of MCSPWM scheme to control the 5 switches placed in proposed inverter topology. The voltage across the switches placed in the proposed inverter varied depends on the generation of stepped output voltage levels, which is shown in Figure 8.

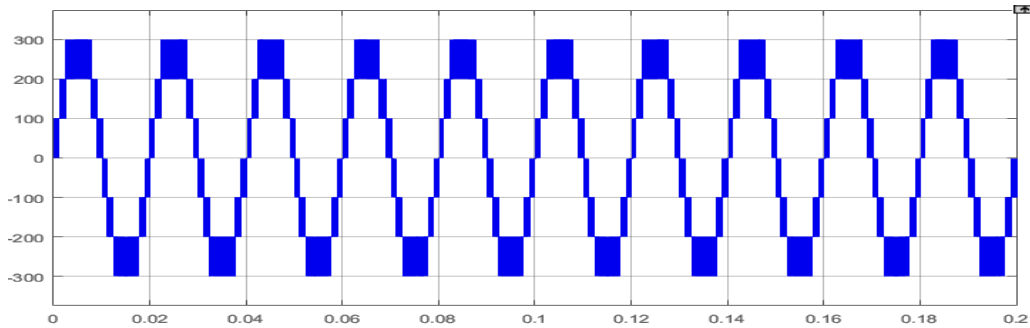

Figure 5. 7-level stepped output voltage of proposed system

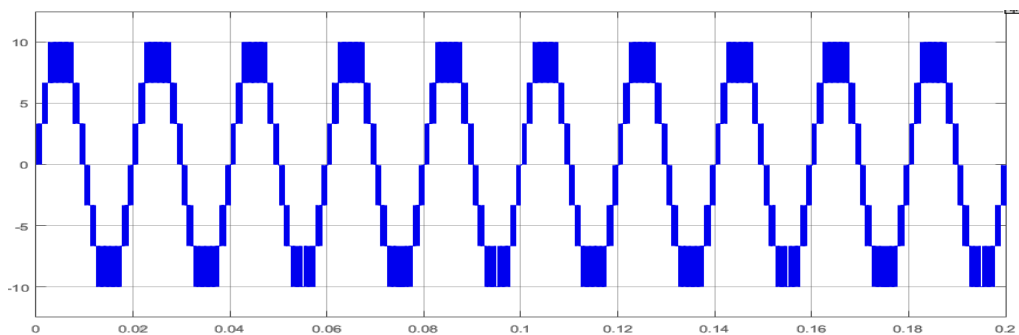

Figure 6. Output current of proposed system inverter topology

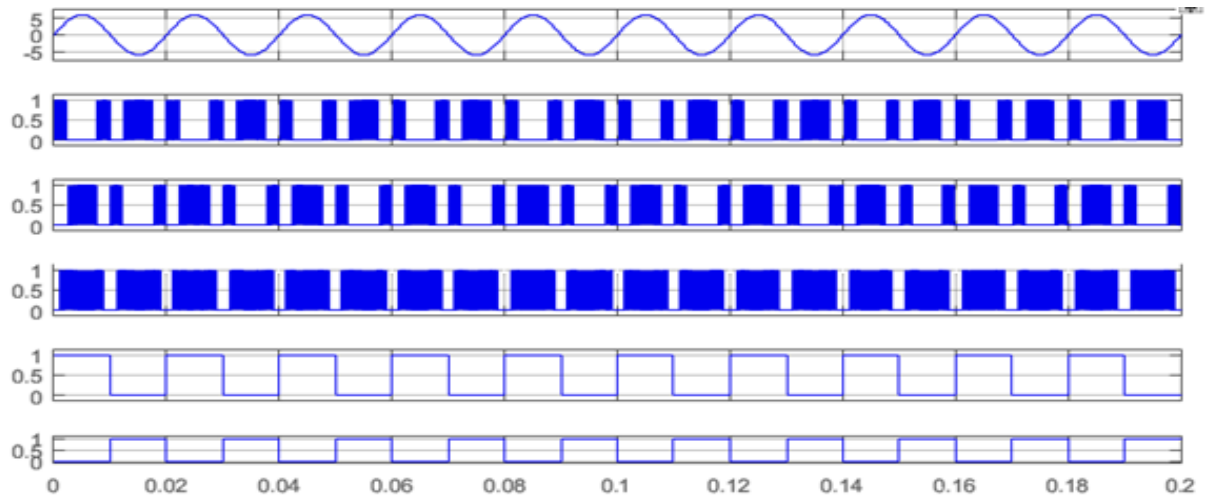

Figure 7. Switching pulses generation using MCSPWM

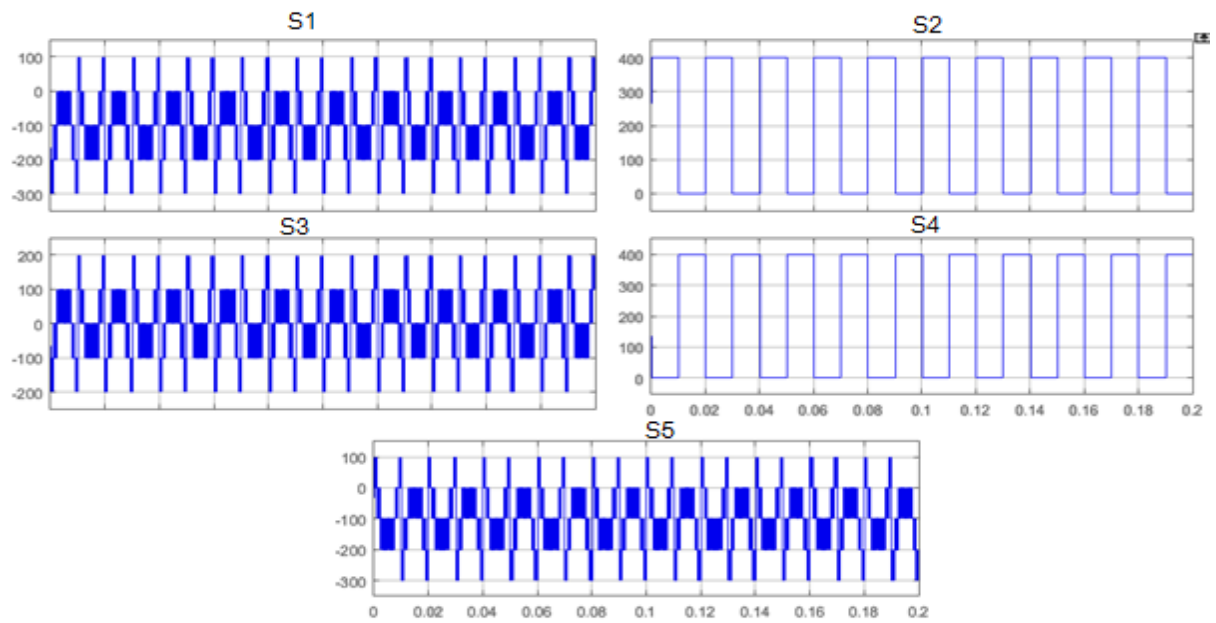

Figure 8. Voltage across the switches placed in the proposed inverter

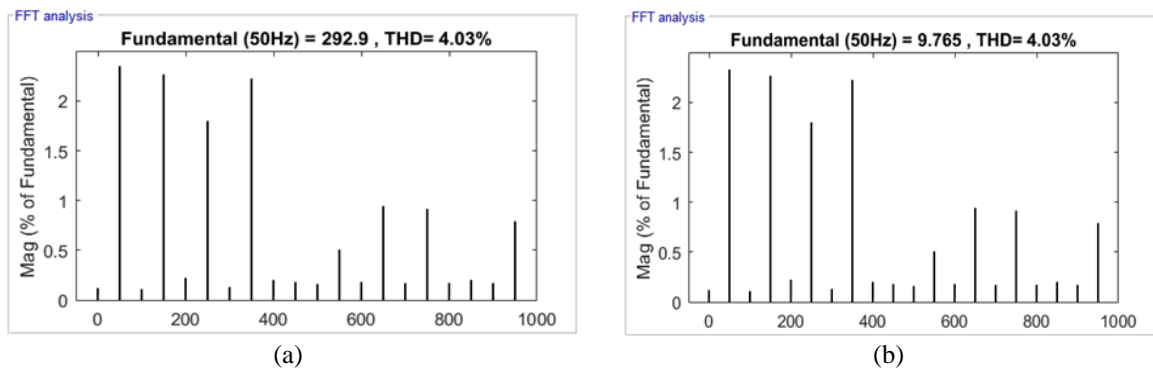

Figure 9. THD analysis of proposed system (a) output voltage (b) output current

In Figure 9 shows THD analysis of proposed 7-level 5 switch novel inverter topology, in that Figure 9a shows the THD for output voltage with 4.03% and Figure.9b shows the THD for output current with 4.03%, which is less than conventional 7-level inverter topologies.

## 6. EXPERIMENTAL RESULTS AND DISCUSSION

To authenticate the simulation results of proposed system, the hardware setup was investigated. In Figure 10 shows the control strategy of proposed inverter system.

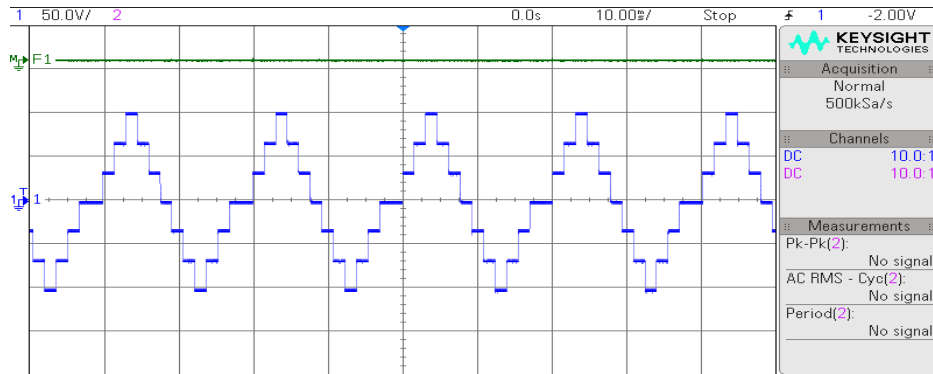

Figure 10. Hardware output voltage of proposed 7-level inverter

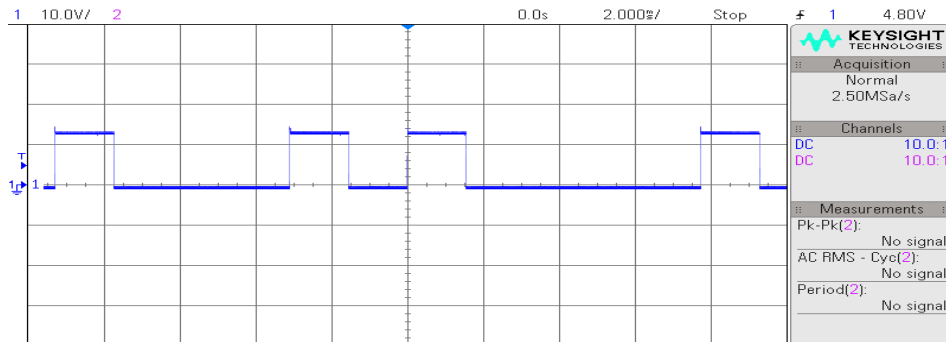

Figure 11. Switching pulse generation using MCSPWM for S1

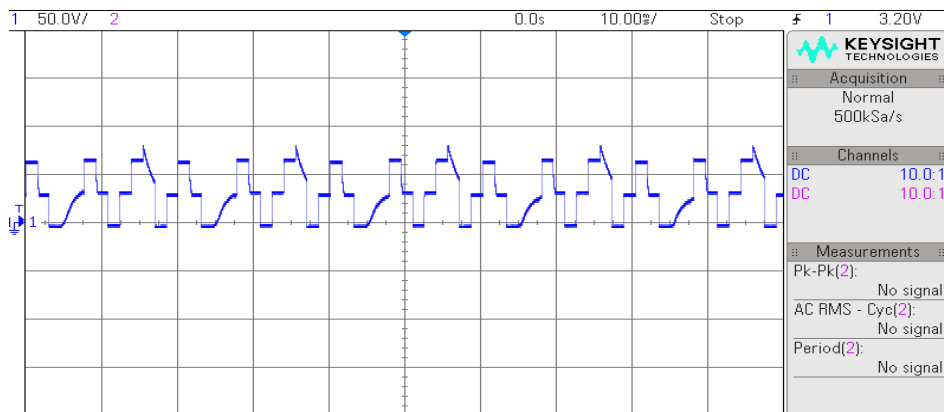

Figure 12. Voltage across the switch S1



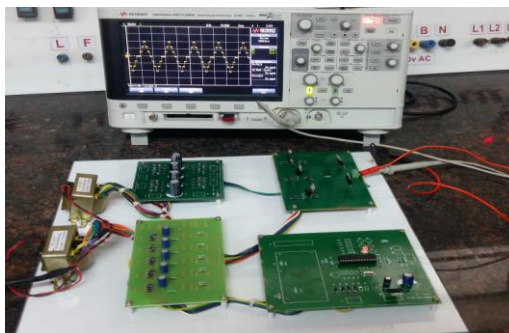

Figure 13. Experimental setup of proposed system

In Figure 10 shows hardware output voltage of proposed 7-level inverter, which is 120V and Figure 11 shows the switching pulse generation using MCSPWM for S1. The voltage across each controlled switches can be measured, which is shown in Figure 12 for switch S1 and Figure 13 shows the experimental setup of proposed system.

## 7. CONCLUSION

In this proposed paper, the multicarrier sinusoidal pulse width modulation scheme was implemented to produce a seven level stepped output voltage with reduced harmonics. The proposed inverter energized by using photovoltaic system, which boosted through the boost converter. Also this system which minimises the common mode voltage level, voltage stress across the various switches improves output and better current control is accomplished. And the simulation and experimental results were verified using matlab 16 and dspic controller respectively.

## REFERENCES

- [1] Poh Chiang Loh, Feng Gao, FredeBlaabjerg, and Sokweilim, "Operational Analysis and Modulation Control of Three-Level Z-Source Inverters With Enhanced Output Waveform Quality," *IEEE Transaction On Power Electronics*, Vol.24, No.7, July 2009.
- [2] SamirKouro, Pablo Lezana, Mauricio Angulo and José Rodríguez, "Multicarrier PWM with Dc-Link Ripple Feedforward Compensation For Multilevel Inverters," *IEEE Transactions on Power Electronics*, Vol. 23, No.1, January2010.
- [3] S. Mohamed Yousuf, P. Vijayadeepan, Dr. S. Latha, "The Comparative THD Analysis of Neutral Clamped Multilevel Z-source Inverter Using Novel PWM Control Techniques" *IJMER Vol.2, Issue.3, May-June 2012 pp-1086-1091*.
- [4] Huafeng Xiao, ShaojunXie, Chen Yang, "Transformerless Split-inductor Neutral pointclamped Three-level PV Grid-Connected Inverter" *IEEE Energy Conversion congress and Exposition (ECCE)*, 2010 pp. 2929-2936
- [5] Bharatiraja, C., Raghu, S., Rao, P., Paliniamy, K.R.S. "Comparative analysis of different PWM techniques to reduce the common mode voltage in three-level neutral-point- clamped inverters for variable speed induction drives", *International Journal of Power Electronics and Drive Systems*, vol. 3, Issue 1, March 2013, Pages 105-116.
- [6] R. Palanisamy, K. Vijayakumar, Komari Nikhil, Madhumathi Iyer, Ramachandar Rao, "A Proposed SVM for 3-level Transformer-less Dual Inverter Scheme for Grid Connected PV System" *Indian Journal of Science and Technology*, 2016 Nov, 9(42).
- [7] Y. Cai, C. Wang, F. Zhao, and R. Dong, "Design of a high-frequency isolated DTHB cLLC bidirectional resonant DC-DC converter," in *Proc. IEEE Conf. Transp. Electrification Asia-Pac.*, 2014, pp. 1–6.
- [8] D. Y. Kim, J. K. Kim, and G.-W. Moon, "A three-level converter with reduced filter size using two transformers and flying capacitors," *IEEE Trans. Power Electron.*, vol. 28, no. 1, pp. 46–53, Jan. 2013.
- [9] Palanisamy R, Vijayakumar K, Misra S, Selvakumar K, Karthikeyan D. A Closed Loop Current Control of PV-Wind Hybrid Source Fed on Grid Connected Transformerless Diode Clamped-Multi Level Inverter. *International Review on Modelling and Simulations*, 2015 Aug; 8(4):122-29.
- [10] Poh Chiang Loh, Feng Gao, FredeBlaabjerg, and Sokweilim. Operational Analysis and Modulation Control of Three Level Z-Source Inverters With Enhanced Output Waveform Quality. *IEEE Transaction on Power Electronics*, July 2010. Vol.24, No.7.
- [11] SamirKouro, Pablo Lezana, Mauricio Angulo and José Rodríguez. Multicarrier PWM with Dc-Link Ripple Feed forward Compensation for Multilevel Inverters. *IEEE Transactions on Power Electronics*, Vol. 23, No.1, January2010.