

Analysis, Design and Investigation on a New Single-Phase Switched Quasi Z-Source Inverter for Photovoltaic Application

C. Bharatiraja¹, P. Sanjeevikumar², Aganti Mahesh³, Ayushi Saxena⁴, K. Padmapriya⁵, B. K. Mithra⁶, AS Swathimala⁷, S. Raghu⁸

^{1,3-7}School Electrical and Electronics Engineering, SRM University, Chennai, India

²Electrical and Electronics Engineering, University of Johannesburg, South Africa

⁸Department of Electrical Engineering, Water Resources Development and Management, IIT Roorkee, India

Article Info

Article history:

Received Feb 3, 2017

Revised Apr 3, 2017

Accepted Apr 17, 2017

Keyword:

Inverter

Photovoltaic application

Quasi Z-source

ABSTRACT

This paper addresses the approach to improve the efficiency of the quasi Z-source inverter. In order to increase the efficiency the reduction of conduction losses is one way to approach. Sequentially to decrease the conduction losses in the quasi z-source inverter the replacement of diode is replacing with switches is proposed which is also called as synchronous rectification. The paper represents basics of the approach, analysis and comparison of the power losses of the traditional and proposed designs of the grid connected PV-system with quasi z-source inverter system. The proposed approach validated on the computer simulations in the MATLAB environment.

Copyright © 2017 Institute of Advanced Engineering and Science.
All rights reserved.

Corresponding Author:

C. Bharatiraja,
School Electrical and Electronics Engineering,
SRM University, Chennai, India.
Email: bharatiraja@gmail.com

1. INTRODUCTION

The quasi z-source inverters (q-ZSI) are drawing more attention than other impedance source networks in photovoltaic (PV) application due to its ability to deal with wide input voltage variation and its shoot-through capabilities and suitable for renewable energy system with large of gain. Feature of the qZSI is that it can draw continuous and constant current. The qZSI boost the input voltage by utilizing an extra switching state is the simultaneous conduction of both switches of the same leg in inverter—which is called as the shoot-through state [1]. This kind of operation forbidden in the traditional voltage source inverters (VSI) because it causes short circuit of the DC link capacitors. In the qZSI, shoot-through state is used to boost the magnetic energy stored in the dc-side inductors (L_1 and L_2 in Figure 1) without short-circuiting the dc capacitors $C1$ and $C2$. During this state, energy is first stored in the impedance network, and then released into the capacitors and load at non-shoot-through states. This increase in inductive energy, in turn, provides the boost of the output voltage V_O during the traditional operating states (active states) of the inverter.

Most of the commercially available grid connected systems for renewable applications include a transformer, which enables the selection of a suitable dc voltage input for the inverter and isolates the energy source from the utility grid [2]. Converters including a transformer either use a line transformer or a high-frequency transformer. Line-frequency transformers are regarded as poor components due to increased size, weight, and prize. Converters with high-frequency transformers include various power stages and are pretty complex. In this paper a new system is proposed, which is having quasi z-source for the boost the voltage and inverter used as grid connected transformer-less system [3], which reduces size and cost. Unipolar pulse width modulation which is most commonly used PWM technique for this kind of system. To reduce the

ripple content for the connection of grid connected system, LC filter is used. Mainly used for the low power and high current applications.

Aim of the paper is to improve the efficiency of the grid connected PV system with qZSI. The power conversion efficiency of the quasi z-source inverter is low because of the conduction loss of a diode rectifier contributes significantly to the overall power loss, especially for low-voltage, high-current converter applications. The conduction loss of a rectifying diode is given by the product of its forward-voltage drop and forward conduction current. By replacing the rectifier diode with a MOSFET operated as a synchronous rectifier (SR) this process also called as synchronous rectification [4]. By this method the equivalent forward-voltage drop can be lowered and, consequently, the conduction loss can be reduced.

In the synchronous rectification method, the gate driving method and proper timing are critical for obtaining high efficiency. This paper describes the benefits and unique challenges of implementing MOSFETs in synchronous rectification process. In this process the unique pulse width modulation is proposed to overcome challenges.

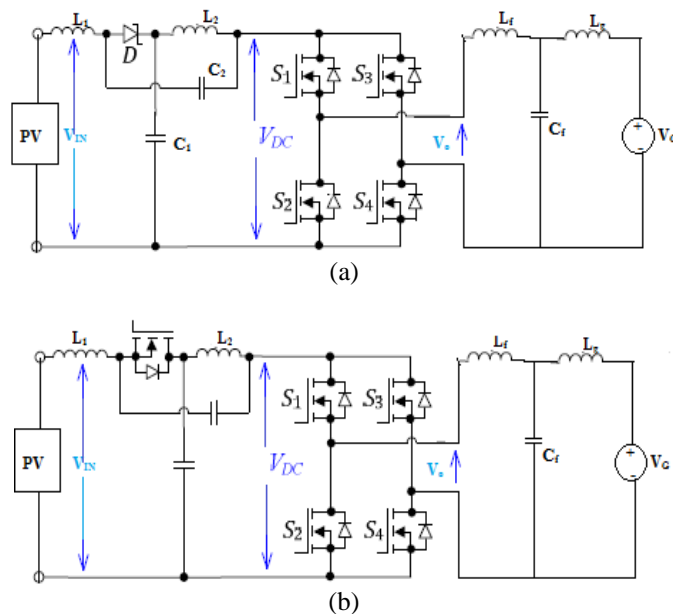

Figure 1. Grid connected qZSI. a) Traditional approach b) Proposed approach

2. OPERATION AND BASIC IMPLEMENTATION OF SR

Basically, the qZSI is a combination of a passive qZS network and an inverter bridge. As shown in Figure 2a, the qZS-network consists of one diode D , two identical inductors (L_1 and L_2) and capacitors (C_1 and C_2). To simplify the analysis, the inverter bridge is replaced by the single MOSFET switch S_{ST} . The shoot-through and active mode operations are operated by single switch S_{ST} . When S_{ST} is turned on (short circuited), it represents the shoot-through state of inverter operation. In this mode switches S_1 and S_2 in the first or S_3 and S_4 in the second leg will be turned on at a time as shown in the Figure 2b. When this occurs and the magnetic energy is stored in the dc side inductors L_1 and L_2 without short-circuiting the dc capacitors C_1 and C_2 . It is one of the advantages of quasi z-source network. During this interval, the inductor current ramps up and V_o is disconnected from V_{IN} . When S_{ST} is turned off (open circuited), it represents the active state of inverter operation. In this state switches S_1 , S_4 , and S_2 , S_3 are turn on. When this occurs, the active (non-shoot through) state emerges and previously stored magnetic energy in turn provides the boost of voltage seen on the load terminals. When shoot-through mode operating the diode D of the qZS is reverse biased which means it's in the turn-off condition.

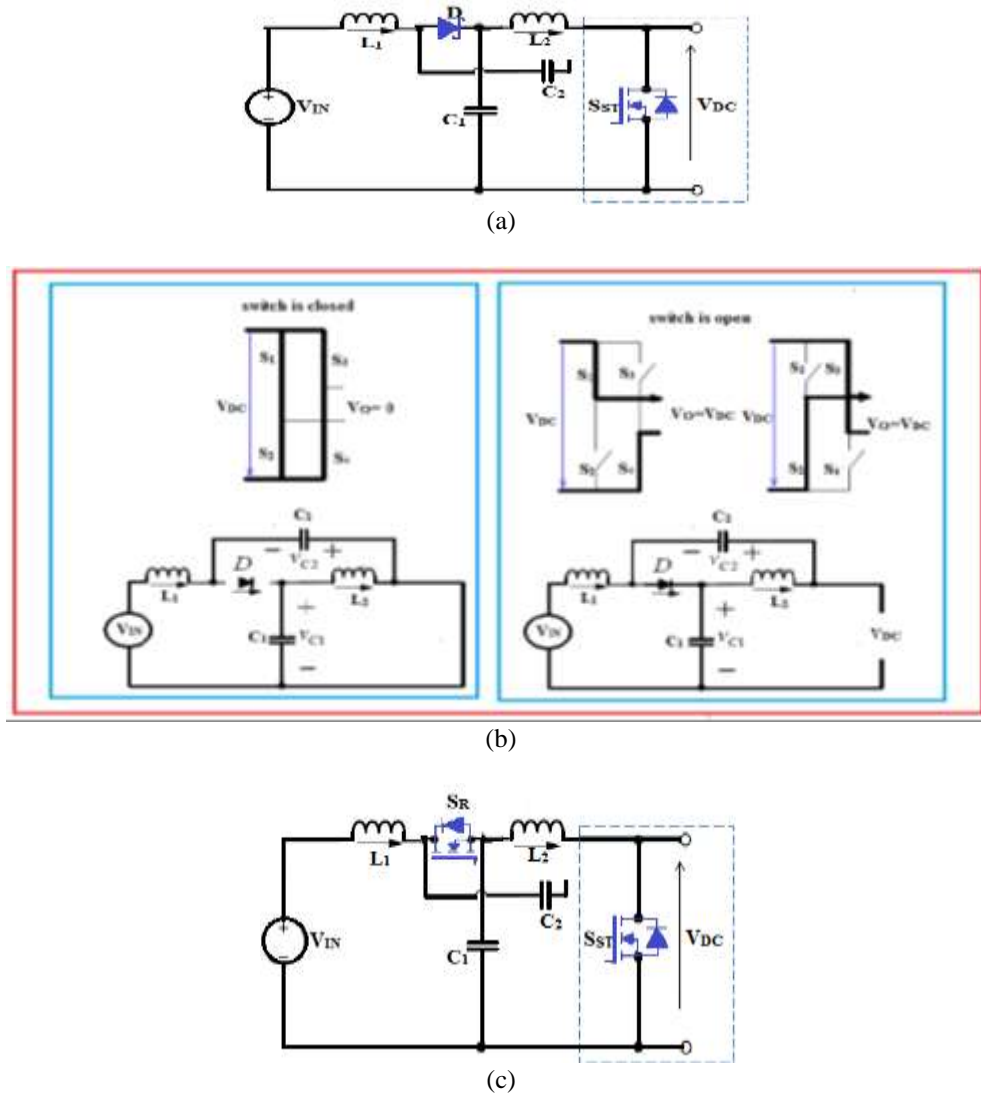

Figure 2. Traditional (a) and its operating (b), synchronous (c) qZS networks

For implementing synchronous qZS-network, in the place of diode D the switch is used. As shown in Figure 2c the MOSFET S_R is used for the synchronous rectification which is operated through the external pulses. The peak output voltage of both topologies is

$$V_{DC\ peak} = \frac{1}{1-2D_{ST}} V_{IN} \quad (1)$$

Where D_{ST} is the shoot-through duty cycle, which represented as:

$$D_{ST} = \frac{T_{ON}}{T} \quad (2)$$

Where T_{ON} is the ON-state time of the MOSFET switch S_{ST} and T is the switching period. The operating DC voltages across the capacitors C₁ and C₂ could be estimated as

$$V_{C1} = \frac{1-D_{ST}}{1-2D_{ST}} \cdot V_{IN} \quad (3)$$

$$V_{C2} = \frac{D_{ST}}{1-2D_{ST}} \cdot V_{IN} \quad (4)$$

To calculate the capacitance value, take the capacitances are equal, the capacitance needed to limit the peak to peak DC-link voltage ripple by r_v , could be calculated as

$$C = \frac{2PD_{ST}}{V_{IN} * V_{DC\ peak} * f_{SW} * r_v} \tag{5}$$

Where C is the capacitance of each capacitor in the qZS network, P is the power rating of the converter, f_{sw} is the switching frequency and r_v , DC is the desired peak to peak voltage ripple at the output of the converter. The main task of the inductors in the qZS-network is to limit the current ripple through the switch during the shoot-through states. Choosing an acceptable peak to peak current ripple r_c the required inductance can be estimated by

$$L = \frac{V_{C1} * D_{ST} * V_{IN}}{P * f_{SW} * r_c} \tag{6}$$

Where L is the inductance of each inductor in the qZS-network, V_{C1} is the operating dc voltage of the capacitor C_1 and r_c is the desired peak to peak current ripple through the inductor.

3. PWM TECHNIQUE AND CONTROL ISSUES

As mentioned before, the diode D is one of the main sources of power dissipation in the traditional qZSI (Figure 1a). This diode is reverse biased during the shoot-through states (Figure 3a) and starts conduction during the active states of the inverter (Figs. 3b and 3c). In the conditions of input voltage V_{IN} the output voltage of the qZSI, V_O is given in Equation 1 [5] to [9].

As shown in Figure 3. The simple and most efficient method of the shoot-through states generation is the overlap of the active states [10]. The duty cycle of active states of transistors is greater than or equal to 0.5. If the duty cycle of active states is greater than 0.5 the cross-conduction of top and bottom transistors (shoot-through) will occur in both inverter legs. During this operating mode the current through inverter switches reaches its maximum. From the practical point of view due to the conduction losses in semiconductors, it is not advisable to operate at the shoot-through duty cycles higher than 0.33. Basically, the diode D of the qZS-network is only needed to avoid short-circuiting of the capacitors C_1 and C_2 during the shoot-through states. At the same time the diode will noticeably increase conduction losses during the active states. To minimize those losses, the N-channel MOSFET SR could be placed instead the diode D , as shown in Figure 1b. The basic idea and main challenges of such modification were explained in [11]. In the given application the SR is synchronized with the inverter switches and it only conducts during the active state and blocks the current during the shoot-through (Table 1).

To prevent damage of the circuit, it is advisable to add small dead-time before the turn on and off transients of the S_R , as shown in Figure 4. From the opposite side, it is not recommended too long in order to limit the conduction time of the body diode, and, therefore, to decrease the power losses.

Table 1. Switching States of Synchronous Rectifier

	Top side		Bottom side		Synchronous switch
	S_1	S_3	S_2	S_4	S_R
Active state	*			*	*
Shoot-through	*	*	*	*	
Active state		*	*		*
Shoot-through	*	*	*	*	

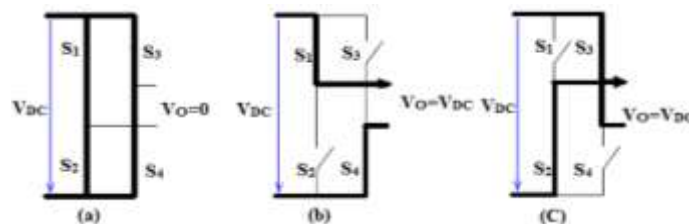

Figure 3. operating states of qZSI shoot through (a), active states (b) and (c)

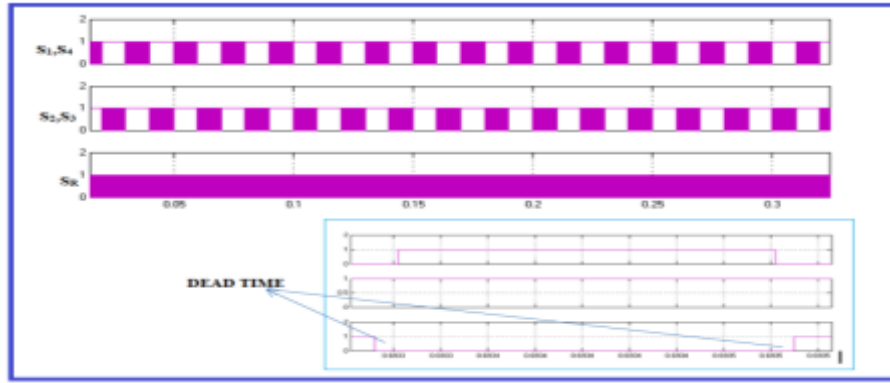

Figure 4. Proposed control principle to operate qZSI

3.1. Filter Design

L-filter is widely used for the inverter to reduce the harmonics. The L filter should be designed with line frequency, so that it requires high inductance value, resulting in cost raising in the order of several kilowatts. By the L-filter dynamic response of the system becomes poor. To improve the dynamic Response of the system LC and LCL filter can be used. LC or LCL filters consisting of small values of inductor and capacitor can replace the low pass filter. The LCL filter needs more space and cost because of two inductors. The efficiency, cost, losses, weight and size are different, depending of the filter type. In this work, an LC filter is designed [12]-[13].

$$L_f = \frac{V_{dc} \cdot V_{dc}}{2 \Delta I_{c,max} \cdot 4} \cdot \frac{1}{2f_{sw}} \quad (7)$$

Where, V_{dc} is the DC link voltage; f_{sw} is the switching frequency of grid connected system. The inverter's maximum current ($I_{c,max}$) is related to the nominal apparent power of the inverter (P) according to the following Equation:

$$I_{c,max} = \frac{\sqrt{2}P}{3V_{ph}} \quad (8)$$

Where, V_{ph} is the phase voltage at the point of common coupling (PCC). 10% ripple of the rated (maximum) current is given by the following Equation:

$$\Delta I_{c,max} = 0.1 \frac{\sqrt{2}P}{3V_{ph}} \quad (9)$$

Thus, based on switching frequency, the value of the inverter- side inductor was selected. For the selection of the filter capacitance, it is considered that the maximum power factor variation seen by the grid should be set to 5%. From the capacitance variation, the overall system impedance base value, Z_B , is calculated as:

$$Z_B = \frac{V_G^2}{P_A/3} \quad (10)$$

$$C_B = \frac{1}{W_N \cdot Z_B} = \frac{1}{2 \cdot \pi \cdot f_{sw} \cdot Z_B} \quad (11)$$

$$C_f = 0.05 C_B \quad (12)$$

Where, W_N is the grid frequency and V_G grid RMS voltage. P_A is the rated active power of the system.

4. ANALYSIS AND SIMULATION RESULTS

First, the benefits of the synchronous rectification (SR) in the qZS-network were studied. The compared inverter having identical stages, the difference lied only in the realization of the qZS-networks (diode vs. MOSFET). To study improvement of output power from the available from the proposed

approach, the power loss analysis was performed in the MATLAB environment. The simulation parameters taken to perform the analysis in Table 1:

Parameter	Value
Input voltage PV	15V
qZS filter values	$L_1, L_2=0.7\text{mH}$ and $C_1, C_2=0.86\mu\text{F}$
DC link voltage	30V
Switching frequency	5000
Switching frequency of SR	10000
Filter	$L_f=0.012\text{H}$ and $C_f=0.14\mu\text{F}$
Grid voltage	20V, 50Hz

For the above parameters the simulation models are designed for with and without synchronous rectification are designed. The output voltage wave forms inverter after filter and before filter is shown in the Figure 5, 6. as shown in the figures the output voltages is same. The output powers of with and without synchronous rectification is shown in the Figure 7 and Figure 8 those Figures shows the improvement in power. If take power at particular time, efficiency improvement we can see.

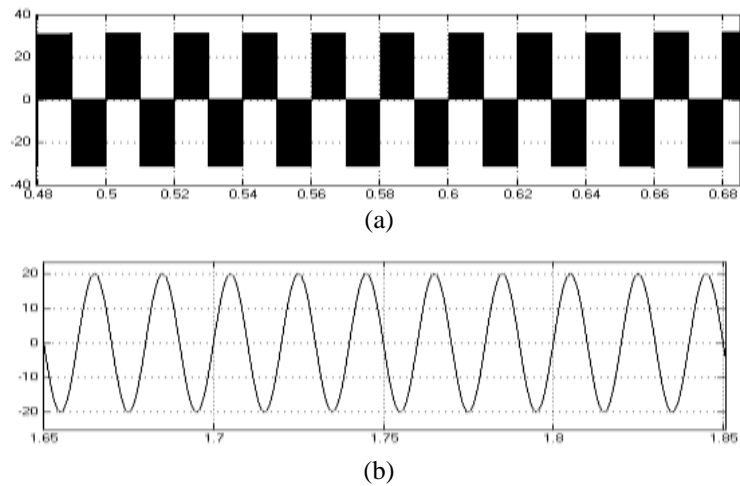

Figure 5. Output voltage waveforms of qZSI (traditional) a) before filter b) after filter

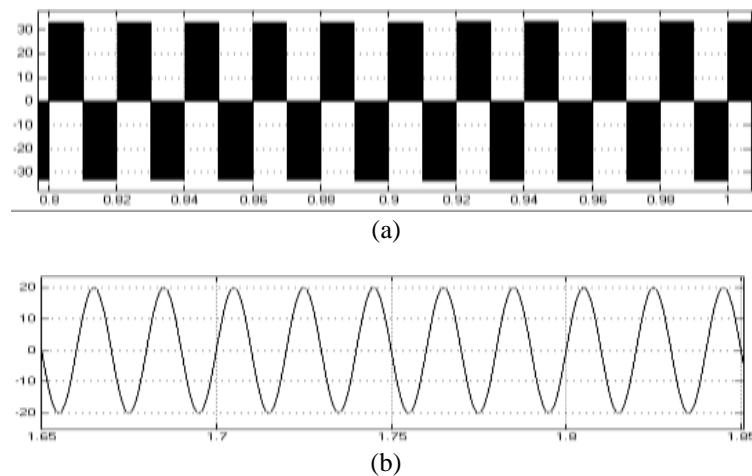

Figure 6. Output voltage waveforms of qZSI (synchronous rectification) a) before filter b) after filter

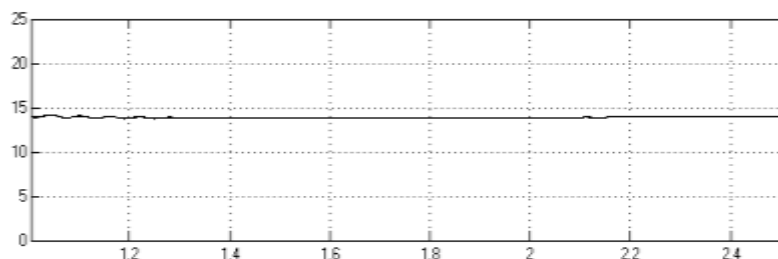

Figure 7. Output power waveforms of qZSI (traditional)

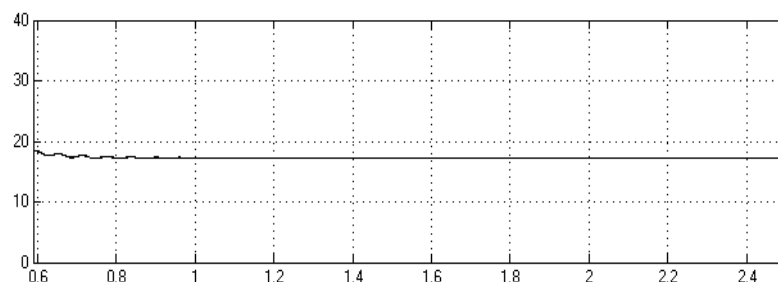

Figure 8. Output power waveforms of qZSI (synchronous rectification)

5. CONCLUSION

This paper has explored the possibility of replacing the diode by MOSFET in order to increase the output power over a diode and increase the efficiency of a qZSI with grid connected system. By observing the Figure 7 and Figure 8. It was found that due to decreased conduction losses the proposed method could result in the increase of output power, it means increase in the efficiency. During the design of the synchronous qZSI, special attention should be paid to the selection of proper delay before the turn on of the rectifying switch to avoid both transistors conducting at the same time that can easily destroy the converter.

REFERENCES

- [1] J. Anderson, F.Z. Peng, "Four Quasi-Z-Source Inverters", in *Proc. IEEE Conf. PESC'08*, pp. 2743-2749, June 2008.
- [2] T. Kerekes, R. Teodorescu, and U. Borup, "Transformer-less photovoltaic inverters connected to the grid," in *Proc. APEC 2007*, Feb. 25–Mar. 01, pp. 1733–1737
- [3] Zakis, J., Rankis, I., Ribickis, L., "Comparative analysis of boost and quasi-Z-Source Converters as Maximum Power Point Trackers for PV panel integrated converters," *IEEE 23rd International Symposium on Industrial Electronics (ISIE)*, 2014, pp.1991,1995, 1–4 June 2014.
- [4] Brian Acker Charles R. Sullivan and Seth R. Sanders "Synchronous Rectification with Adaptive Timing Control," *IEEE Power Electronics conference*, vol.1, pp.88-91, 1995.
- [5] Vinnikov, D., Roasto, I, "Quasi-Z-Source-Based Isolated DC/DC Converters for Distributed Power Generation," *IEEE Transactions on Industrial Electronics*, vol.58, no.1, pp.192, 201, Jan. 2011.
- [6] LaBella, T., Lai, J.S., "A Hybrid Resonant Converter Utilizing a Bidirectional GaN AC Switch for High-Efficiency PV Applications," *Twenty-Ninth Annual IEEE Applied Power Electronics Conference and Exposition*, 2014. pp.1, 8, 16-20 Mar. 2014.
- [7] Vinnikov, D., Roasto, I., Zakis, J., Strzelecki, R. "New Step-Up DC/DC Converter for Fuel Cell Powered Distributed Generation Systems: Some Design Guidelines". *Przegląd Elektrotechniczny*, vol. 86 (8), pp. 245–252, 2010.
- [8] Vinnikov, D.; Roasto, I, "Impact of component losses on the voltage boost properties and efficiency of the qZS-converter family," *7th International Conference-Workshop Compatibility and Power Electronics (CPE)*, pp. 303,308, 1–3 June 2011.
- [9] Vinnikov, D.; Roasto, I; Zakis, J., "New bi-directional DC/DC converter for supercapacitor interfacing in high-power applications," *2010 14th International Power Electronics and Motion Control Conference (EPE/PEMC)*, pp.T11-38, T11-43, 6–8 Sept. 2010.
- [10] C.Bharatiraja, S.Jeevananthan, R.Latha, "Vector Selection Approach-based Hexagonal Hysteresis Space Vector Current Controller for a Three-phase Diode Clamped MLI with Capacitor Voltage Balancing", *IET Power Electronics*, vol.9, Issue 7, pp.1350-1361, 8 June 2016.

- [11] Roasto, I., Vinnikov, D., Jalakas, T., Zakis, J., Ott, S., "Experimental study of shoot-through control methods for qZSI-based DC/DC converters," 2010 *International Symposium on Power Electronics Electrical Drives Automation and Motion (SPEEDAM)*, pp. 29,34,14–16 June 2010.
- [12] Liivik, L., Vinnikov, D., Jalakas, T., "Synchronous Rectification in Quasi-Z-Source Converters: Possibilities and Challenges". 2014 *IEEE International Conference on Intelligent Energy and Power Systems (IEPS2014)*, pp 32–35, June 2–6, 2014, Kyiv, Ukraine. *Industry Applications*, vol. 41, no.5, pp. 1281 – 1291, sep./Oct. 2005.
- [13] E. Twining and D. G. Holmes, "Grid Current Regulation of a Three Phase Voltage Source Inverter with an LCL Input Filter," in *IEEE Transactions on Power Electronics*, vol. 18, no. 3, pp. 888-895, May 2003.
- [14] K. H. Ahmed, S. J. Finney, and B. W. Williams, "Passive Filter Design for Three-Phase Inverter Interfacing in Distribution Generation," *Journal of Compatibility in Power Electronics (CPE'07)*, vol. 12, no.2, pp. 1-9, May/June 2007.
- [15] C.Bharati Raja, S. Raghu, "Comparative Analysis of Different PWM Techniques to Reduce the Common Mode Voltage in Three-Level Neutral-Point-Clamped Inverters for Variable Speed Induction Drives," *International Journal of Power Electronics and Drive Systems.*, vol 3, no 1, pp.105-155, March 2013
- [16] C. Bharatiraja, J.L. Munda, N. Sriramsai, T Sai Navaneesh, "Investigation of the Common Mode Voltage for a Neutral-Point-Clamped Multilevel Inverter Drive and its Innovative Elimination through SVPWM Switching-State Redundancy," *International Journal of Power Electronics and Drive Systems*, vol.7, no.3, pp892-900,2016.
- [17] T.K.S Sathayanarayanan, M Ramasamy, C Bharatiraja, JL Munda, "Modelling, Impedance Design, and Efficiency Analysis of Battery Assists PV tied Quasi-Z source inverter," *International Journal of Power Electronics and Drive Systems*, vol.7, no.3, pp.812-821, 2016.