

The Calibration Test of Hybrid Landfill Gas -Photovoltaic-Genset Model in Bontang, East Borneo

Salama Manjang¹, Sitti Hammah Ahsan²

Department of Electrical Engineering Universitas Hasanuddin Makassar 90245, Indonesia

Article Info

Article history:

Received Oct 4, 2017

Revised Jan 2, 2018

Accepted Jan 15, 2018

Keyword:

IPCC

Landfill Gas Emissions

Waste Composition

Waste Reductions

Waste to Energy

ABSTRACT

The study is aimed to determine the measurement of sensor tool made in Model Real Time Hybrid LFG-PV-Genset by finding the correction factor produced at TPA Bontang City, East Borneo. The research was conducted by using ampere clammeter, variable voltage regulator, thermometer, odalog7000 series. The calculation results show that the calibration test of Model Real Time Hybrid LFG-PV-Genset from MQ4 sensor data that has been designed capable of having errors of 1,91% and the LM35 temperature sensor is capable of monitoring temperatures of 30^oC to 120^oC and has an error value of 0,519^oC. ZMPT 101B voltage sensor has a linear output change to input changes and has an average error of 1.499V. While the current sensor SCT 013 has an average error value of 0,0022A CO₂.

Copyright © 2018 Institute of Advanced Engineering and Science.
All rights reserved.

Corresponding Author:

Sitti Hammah Ahsan,

Department of Electrical Engineering Department,

Universitas Hasanuddin,

COT (Centre Of Technology),CO-1F-7, B- Research and Development, Jl. Poros Malino KM6 Gowa

92173, South Sulawesi, Indonesia.

Email: agusamir61@yahoo.com

1. INTRODUCTION

The fulfillment of the need for electrical energy, especially from the conventional electric power plant (by fuel, gas and coal) directly contributes to the increase of the emissions of CO₂ and CH₄ of greenhouse gasses (GHGs) to the atmosphere which result in the increasing temperature on earth that obstructs the balance process due to the disruption of the carbon cycle in the atmosphere [1]. The efforts of reducing the concentrations of CO₂ and CH₄ emitted to the atmosphere can be conducted by developing the renewable energy to meet the demand of electrical energy, one of which is the development of Hybrid Power System (HPS) technology that combines several energy sources to generate the greater energy. The development of HPS is not only environmentally friendly, but also able to operate in the areas out of the reach of PLN network, for example the use of Hybrid Photovoltaic (PV)/Genset/ battery, PV/wind/battery, PV/wind/genset/battery [2].

There have been some research conducted, such as the research on the potential contribution of the Waste to Energy facility to meet the needs of electricity in three major cities in the eastern provinces of Saudi Arabia, which are three utilizations of the developed Waste to Energy: incineration generation, recycling generation, Refused Derived Fuel (RDF) with biomethanation [3]. The research conducted on the waste energy potential of waste incineration from the landfill gas (LFG) produced 1125 PJ in 2012 and 2199 PJ in 2025 [4]. Ansar Sayuti conducted a research on the design of real time gas emission tester for diesel power plant applications using the MQ2 gas sensor for smoke opacity, KE sensor for O₂ [5]. Alawani [6], in his thesis, designed a hybrid microgrid system of hybrid PV and wind turbines to select the most suitable size according to target power supply at economical cost in rural areas outside Yanbu City, Saudi Arabia. The

weakness of these research is that there have been no model that integrates two or more local energy sources in real time with economical and low emission materials.

Although the studies on renewable energy have much developed, but no one has conducted a Real Time Model Research on the Hybrid LFG-PV-Genset for tropical climate, and Bontang City is traversed by the equator, which has the advantage that the CH₄ methane gas content is higher as a producer of landfill gas. This potential will be utilized in Bontang City since, geographically, it is located on the equator at 117°021'–117°029' E and 0°001'–0°011' N with a potential solar radiation level of approximately 4,8 kW/m²/day [7] the mitigate conversion of the resulted CH₄ gas is 28.786.022 kWh per year [8]. In this model, the calibration instruments used were the ampere clammeter, variable voltage regulator, thermometer, odalog 7000 series. The instrument calibration is aimed to adjust the data resulted from the sensor measurement made in the Real Time Model Hybrid LFG-PV-Genset with standard instruments by finding the correction factors [9], [10]. The purpose of this research is to design and to find out the deviation of sensor of the sensors calibration measurement system of the Test of Real Time Model Hybrid Power Landfill-PC-Genset System in order to find out the CH₄, methane gas content, temperature, voltage and current in the calibration instruments.

2. CASE STUDY

2.1. The System of Schematic System

Figure 1. illustrates a schematic sequence of the systems of measurement, database and data presentation. The measurement system is divided into 2 parts: the central measurement system and the connecting measurement system. The central measurement system is photovoltaic side, landfill biogas site and generator side genset. The connecting measurement system consists of 3 sensors of parameters, they are; smart monitor & datalogger photovoltaic, smart & datalogger landfill biogas site and smart & datalogger genset. The smart & datalogger photovoltaic consists of two sensors of current and voltage. The smart & datalogger landfill biogas consists of three sensors; MQ4 methane detector sensor, current sensor and voltage sensor. The smart & datalogger genset consists of two sensors; ac current sensor and ac voltage sensor. These three smart & datalogger containing those sensors are connected to a signal conditioning circuit that adjusts the sensor output to the arduino microcontroller input.

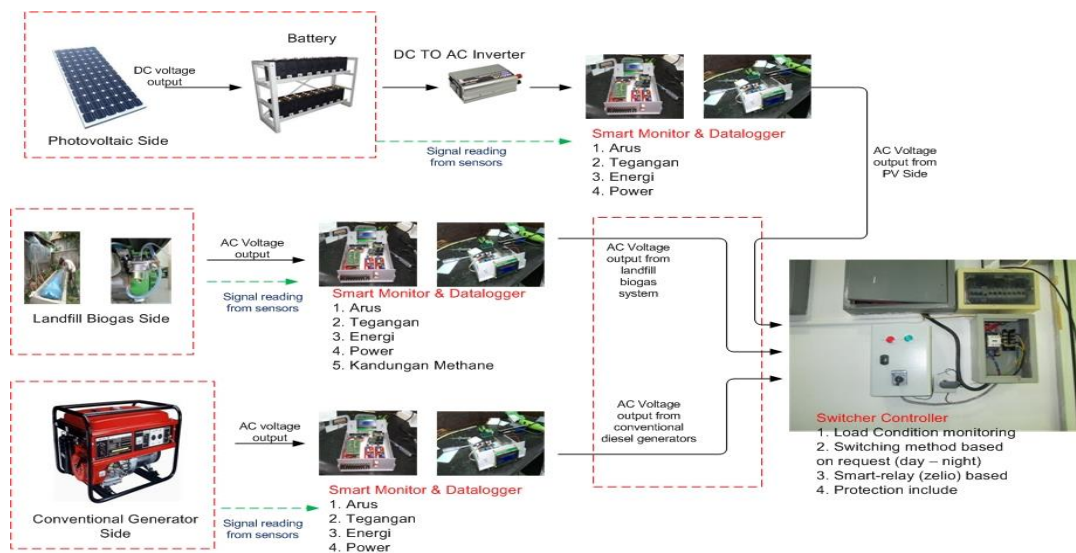

Figure 1. The schematic sequence of the system

2.2. Sensor

The sensors should be calibrated in the system where it will be used to achieve the best accuracy, since there is no sensor is perfect, from the sample to sample of manufactured variations means that even running two sensors from the same producer can result in slightly different readings. The difference in sensor design means that two different sensors can respond differently under the same conditions [11]. It especially applies in the 'indirect' sensors that calculate the measurements based on one or more actual measurements of several different but related parameters. Another reason is that the sensor is only one component in the

measurement system. For example, with an analog sensor, your ADC is a part of the measurement system and also depends on the variability, the temperature measurement depends on the thermal gradient between the sensor and the point of measurement.

2.2.1. MQ4 Methane Gas Sensor

The MQ4 sensor, as shown in Figure 2, is a gas sensor which has high sensitivity to *combustible gases*, especially for CH₄ methane gas, as well as to other gases, such as propane and butane. The MQ4 sensor has the SnO₂ material that is sensitive to changes in *combustible gas*. This material has a low conductivity when in the open air that does not contain *combustible gas* and has a higher conductivity when there is a change in the concentration. The concentration of gas content that the MQ4 sensor can reach is 300-10000 ppm [12].



Figure 2. MQ₄ Sensor and Odalog7000 Calibration Tool

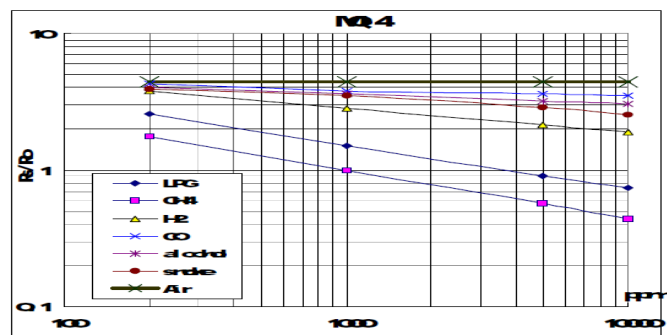

Figure 3. Characteristics of MQ4 sensor

In addition, Figure 3 represents the characteristics of the MQ-4 sensor sensitivity and the characteristics of temperature and humidity dependence. The x-axis represents the gas concentration in ppm, while the y-axis indicates the ratio of the specified sensor resistance, where R_s is the sensor resistance at a certain concentration and R_0 is the sensor resistance at 1000 ppm of methane gas in open air.

2.2.2. LM35 Temperature Sensor

Figure 4. LM35 sensor is a small-sized temperature sensor component such as a transistor (TO-92). This very easy-to-use component is capable of measuring temperature up to 100 degree Celsius. The LM35 temperature sensor is an electronic component that has a function of converting the temperature to electrical quantity unit in the form of voltage. The LM35 sensor has a high accuracy and easy in design compared to other temperature sensors. It also has a low impedance output and high linearity, so that it can be easily connected to a special control circuit and does not require advanced setup with a linear-scaled output voltage with measured temperature, 10 millivolts per 1 degree celsius. Although this sensor voltage can reach 30 volts, but it has only 5 volts provided to the sensor, so it can be used in a single power supply provided that the it only requires a current of 60 μ A It means that the LM35 sensor has the ability to perform self-heating from the sensor which can cause a low reading error of less than 0,5 $^{\circ}$ C at 25 $^{\circ}$ C.



Figure 4. LM35 temperature sensor and temperature calibration tool

2.2.3. ZMPT101B Voltage Sensor

Figure 5. ZMPT101B Ultra Micro Voltage Transformer has a small size, high accuracy, good consistency for voltage and power measurement.

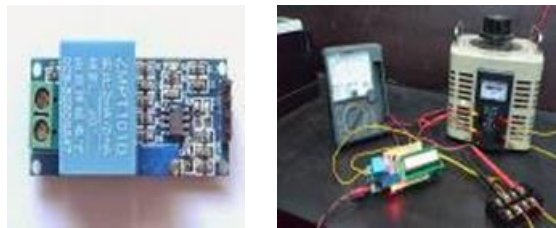

2.2.4. Current Sensor

The measurement or electric current detection is one of the main parameters required in electricity. For example, for the large current measurement, power measurement and protection parameter. Current Transformer or CT is one of the instrumentation transformers which produces current in the secondary where the magnitude suited to the ratio and the primary current.

Current Transformer generally consists of an iron core which is coiled by a conductor for hundred times. The output of the secondary is usually 1 or 5 Amperes, indicated by the ratio owned by the CT. For example, 100: 1, means that the CT secondary will have an output of 1 Ampere if the primary side is passed by 100 ampere current. If the ratio is 400: 5, then the CT secondary will have an output of 5 Amperes if the primary side is passed by 400 ampere current. This sensor is non-invasive, so that it can be used without changing the wiring existing in advance. The procedure is that the induction coil that detects the changes of magnetic field around the current-carrying conductor. By measuring the amount of current generated by the coil, we can calculate the amount of current passing through the conductor. The following is the specification of current sensor (Non-Invasive Current Transformer):

2.2.5. Mikrocontroller Arduino Mega 2560 Rev. 3

Arduino is both hardware and software of a microcontroller-based electronic circuit easily and fastly. One of the Arduino boards is shown in Figure 6. More specifically, the microcontroller-based Arduino board used is the Arduino Mega by using the ATmega Rev3 microcontroller. In terms of software, Arduino IDE (Integrated Development Environment) is a useful tool for writing programs (specifically named sketch in Arduino), compiling and simultaneously uploading them to the Arduino board. The basic Arduino Programming Language is C/C++.



Figure 6. Current Sensor and temperature calibration tool

The structure of the arduino mega 2560 is shown in the Figure 7. Especially for digital pins, every pin is only assigned to handle one of the modes, which is either as the input or output. If it becomes an input, the value on pin will be determined by the outsider and can be read through digitalRead() command. If it becomes an output, the value on the pin is set by Arduino and can be determined by the digitalWrite() command. The determination of a pin mode as input or output is determined by pinMode().

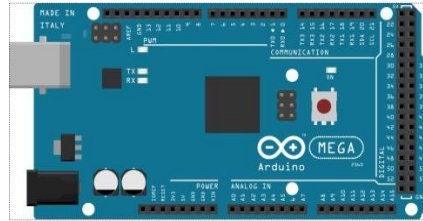

Figure 7. Arduino Mega 2560 (Rev 3)

3. DESIGN SYSTEM

3.1. Flowchart of The Processes of HPS LFG-PV-Genset Calibration Measurement

Figure 8 presents that the is input circuit consisting of four sensors; voltage sensor, current sensor, temperature sensor and CH₄ methane gas sensor which is the MQ4 sensor to read/measure the magnitude of CH₄ methane gas which has 1 pin input connected to pin A5, AC sensor of pin8 to analog A1 in arduino microcontroller and voltage sensor to analog pin A2 in arduino microcontroller. Then, the arduino mega2560 rev3 ADC microcontroller transforms its value to the digital form. Therefore, the hardware design consisting of arduino Mega R3 microcontroller, MQ4 sensor circuit and LCD circuit. This sensor circuit is the main circuit in designing the smart datalogger biogas site.

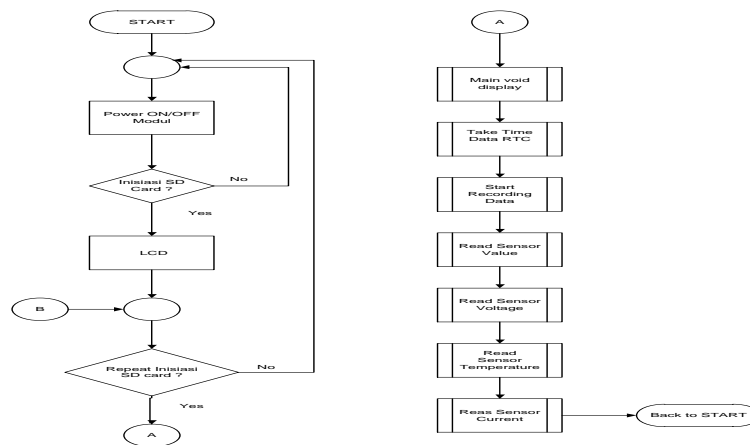

Figure 8. Flowchart of the processes of HPS LFG-PV-genset calibration measurement

3.2. The Schematic Design of HPS LFG-PV-Genset Sensor

Figure 9 illustrates the hardware design consisting of arduino Mega R3 microcontroller, MQ4 sensor circuit and LCD circuit. This circuit is in the smart datalogger biogas site. The input circuit consists of the CH₄ methane gas MQ4 sensor to read/measure the magnitude of CH₄ methane gas which has 1 pin input connected to pin A5, AC sensor of pin8 to analog A1 in arduino microcontroller and voltage sensor to analog pin A2 in arduino microcontroller. Then, the arduino Mega2560 rev3 ADC microcontroller transforms its value to the digital form. The microcontroller circuit used is Arduino Mega ADK Rev3 board-based microcontroller by using ATmega2560 chip. This board has a lot of I/O pins; 54 digital I/O pins (15 pins of which are PWM), 16 analog input pins, 4 UART pins (serial port hardware). The Arduino Mega 2560 is equipped with a 16 Mhz oscillator, a USB port, DC power jack, ICSP header, and a reset button. This board

is very complete. It already has everything needed for a microcontroller. With a fairly simple usage, it just needs a connection to the power from the USB port to your PC or through the AC/DC adapter to the DC jack.

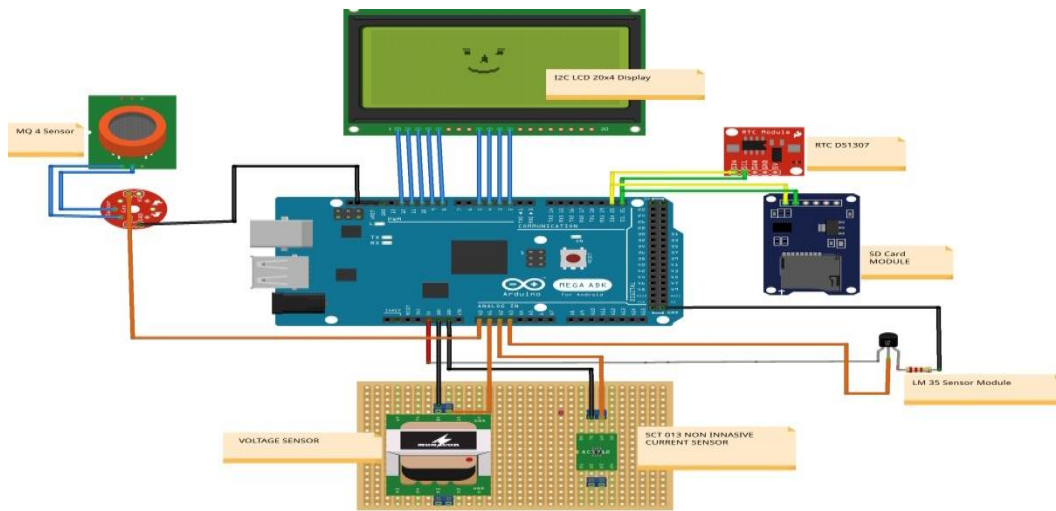

Figure 9. The schematic circuit of HPS LFG-PV-genset sensor

4. RESULTS

The results of the tool calibration test are as follows:

4.1. The Calibration Test of CH₄ Methane Gas Sensor

The output value of the MQ4 sensor is in the form of resistance. In order to get the output of voltage, it is given for a voltage divider circuit. The purpose of the measurement of MQ4 methane gas sensor is to determine the value of ADC data on MQ4 sensor. The methane calibration using adalog7000 was conducted at the exit point of the vessel and the ADC data output was then recycled using the Arduino port. ADC data obtained from the measurement of the MQ4 methane gas sensor are shown in Table 1.

Table 1. The Results of Calibration of ADC Data of MQ4 Sensor

1	Sensor MQ4 Reading	58.75	58.75	58.75	58.75	58.74	58.72	58.71	58.69	58.66	58.65	58.64	58.63	58.62	58.62
2	Adalog7000	61	61	61	61	61	61	61	61	61	60	60	60	60	60
3	Deviation (%)	2.25	2.25	2.25	2.25	2.26	2.28	2.29	2.3	2.32	1.34	1.36	1.36	1.37	1.8

From the results of calibration test, the largest difference is obtained in the deviation of 2,28%, with the smallest difference of 1,34%. The result of the experiment showed that the data acquisition system of CH₄ methane gas has an error of 1,91%. The value was obtained by summing up all error values of each test divided by the number of tests (15 times).

4.2. The Calibration Test of LM35 Temperature Sensor Circuit

The test of LM35 sensor was conducting by providing 5 volts on the leg of Vcc sensor as the activation, and then was measured for the output voltage. The value of output voltage was compared with the temperature calibration value using solder variable supply with temperature display. The load used is using incandescent lamp. The data resulted are as follows in Table 2.

Table 2. The results of calibration of ADC data of LM35 sensor

1	Sensor Reading	1,12	41,95	51,23	63	70,65	83	93,01	101,23	112,3	123,76
2	Temperature Solder	30	40	50	60	70	80	90	100	110	120
3	Thermometer	30,2	41,15	51,56	62,05	71	83,06	92,36	100,06	112	122,57
4	Deviation (A)	0,92	0,8	-0,33	0,95	-0,35	-0,06	0,65	1,17	0,25	1,19

From the data above, it can be seen that the output voltage of LM35 is linear with a change of 0.01 volts (10mV) for every either increase or decrease in temperature per 1°C. The data shows the LM35 temperature sensor used in the system design is accurate in temperature readings. The output data of LM35 sensor are the analog data which will be converted to ADC digital data through microcontroller execution. The result of experiment shows that the acquisition system of temperature data has an error of 0.519°C, The value was obtained by summing up all error values of each test divided by the number of tests (10 times).

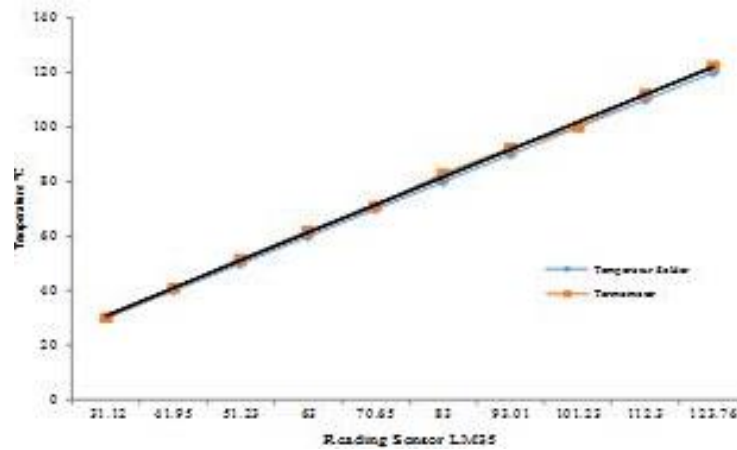

Figure 10. The graphic of calibration of MQ sensor resulted from the proposed design

4.3. The Calibration Test of SCT 013 Non-Invasive Current Sensor Circuit

The working principle of this current sensor is to detect the magnetic field of the current wire with IC Hall effect which is already integrated within. The amount of incoming current is proportional to the magnitude of the generated magnetic field. Table 3 shows results of calibration of ADC data of SCT 013 sensor.

Table 3. The Results of Calibration of ADC Data of SCT 013 Sensor

1	Load (watt)	100	140	160	175	200	240	260	275	300	340
2	I multimeter (A)	0,18	0,25	0,29	0,32	0,36	0,44	0,47	0,51	0,54	0,62
3	I Sensor Reading (A)	0,191	0,273	0,300	0,327	0,355	0,44	0,46	0,494	0,52	0,6
4	Deviation (A)	-0,011	-0,023	-0,01	-0,007	0,005	0,003	0,008	0,012	0,02	0,019

SCT 013 Non-invasive current sensor test was conducted by providing 100 to 340 watts of load, while the direct current output was observed data were obtained in Figure 11.

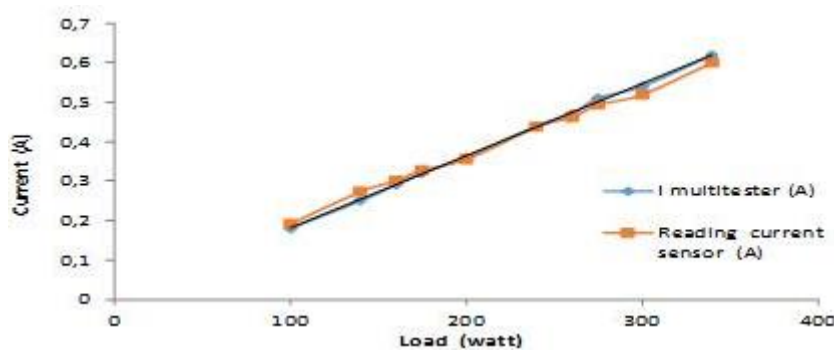

Figure 11. The graphic of calibration of SCT 013 non-invasive sensor from the proposed design

The result of experiment shows that the acquisition system of current data has an error of 0.0022 A. The value was obtained by summing up all error values of each test divided by the number of tests (10 times).

4.4. The Calibration Test of ZMPT101B Voltage Sensor Circuit

Figure 12 shows result of experiment shows that the acquisition system of current data has an error of 1,499 V. The value was obtained by summing up all error values of each test divided by the number of tests (28 times).

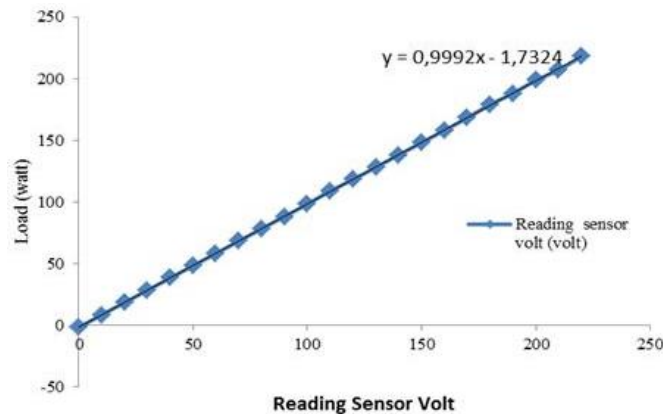

Figure 12. The graphic of calibration of ZMPT101B sensor from the proposed design

5. CONCLUSION

Based on the data and the results of the discussion conducted, the conclusions are as follows:

- Based on the result of calibration test of Hybrid Landfill Gas-Solar-Genset Model, it is found that the designed MQ₄ sensor has an error value of 1,91%, and LM35 temperature sensor is able to monitor temperature ranging from 30°C to 120°C and has an error value of 0,519°C. ZMPT101B voltage sensor has a linear output change to the input change and has an average error value of 1,499 V. While the SCT 013 current sensor has an average error value of 0,0022A.
- From the calibration process, it can be concluded that the Hybrid Landfill Solar Cell Gas and Genset Model has a good accuracy with small resolution, thus, this prototype can be used with a good real-time reading result.
- After assembling the DHT11 Temperature Sensor, Voltage Sensor and SCT 013 Current Sensor into Arduino and connecting it to *Power Supply*, then connecting the Arduino to the computer through the USB cable, the computer will detect the existence of Arduino with the *port* it used.

ACKNOWLEDGEMENTS

The authors are thankful to Prof. Dr. Dwia Aries Tina Pulubuhu, Rector University of Hasuddin Makassar and also Government of Bontang City for providing the necessary facilities for the preparation of the paper

REFERENCES

- [1] M. S. Ngan and C. W. Tan, "Assessment of economic viability for PV/wind/diesel hybrid energy system in southern Peninsular Malaysia," *Renew. Sustain. Energy Rev.*, vol. 16, no. 1, pp. 634–647, 2012.
- [2] K. Nipon, "Photovoltaic Hybrid Systems for Rural Electrification in the Mekong Countries," Kassel University, Jerman, 2005.
- [3] O. K. M. Ouda, S. A. Raza, R. Al-Waked, J. F. Al-Asad, and A.-S. Nizami, "Waste-to-energy potential in the Western Province of Saudi Arabia," *J. King Saud Univ. - Eng. Sci.*, 2015.
- [4] N. Scarlat, V. Motola, J. F. Dallemand, F. Monforti-Ferrario, and L. Mofor, "Evaluation of energy potential of Municipal Solid Waste from African urban areas," *Renew. Sustain. Energy Rev.*, vol. 50, pp. 1269–1286, 2015.
- [5] A. Suyuti, M. Tola, M. S. Pallu, and N. Harun, "Design of Real-Time Gas Emission Tester for Diesel Power Plant Applications," *Int. J. Electron. Commun. Comput. Eng.*, vol. 4, no. 1, pp. 1607–1612, 2012.

- [6] S. H. Alalwani, "Optimal techno-economic sizing of wind/solar/battery hybrid microgrid system using the forever power method," Missouri University of Science and Technology, 2015.
- [7] S. Hamnah Ahsan, Salama Manjang, Wihardi Tjaronge, "Energy Yield of Photovoltaic (PV) System Supporting Hybrid Power Generation in Bontang City, Indonesia," *ICIC EXPRESS Lett.*, vol. 9, no. 11, pp. 3127–3134, 2015.
- [8] S. H. Ahsan, S. S. Manjang, and M. Baharuddin, "Potensial Renewable Energy From Waste Mitigation of Gas Emissions of CH₄ and CO₂ in Bontang City, East Borneo," in International Conference on Green Energy, 2017.
- [9] M. Webster, JohGn; Aller, The Measurement Instrumentation And Sensors Handbook. New York, USA: CRC Press LLC, 1999.
- [10] R. N. Naik, P. S. N. Reddy, S. N. Kishore, and K. T. Kumar Reddy, "Arduino Based LPG gas Monitoring & Automatic Cylinder booking with Alert System," *IOSR J. Electron. Commun. Eng.*, vol. 11, no. 4, pp. 06–12, 2016.
- [11] X. Liu, S. Cheng, H. Liu, S. Hu, D. Zhang, and H. Ning, "A survey on gas sensing technology," *Sensors (Switzerland)*, vol. 12, no. 7, pp. 9635–9665, 2012.
- [12] S. K. Srivastava, "Real Time Monitoring System for Mine Safety using Wireless Sensor Network (Multi-Gas Detector) Real Time Monitoring System for Mine Safety using Wireless Sensor Network (Multi-Gas Detector)," Institute of Technology Rourkela, 2015.

BIOGRAPHIES OF AUTHORS



Salama Manjang He received his Doctor degrees in electronic and electrical engineering from Institut Teknologi Bandung. Currently, he is a professor in the Department of Electrical Engineering. He is currently the head of Department Electrical Engineering in Universitas Hasanuddin Makassar. His current research interests include power energy and renewable energy . Email: salamamanjang@unhas.ac.id



Sitti Hamnah Ahsan. Currently, she is pursuing a Doktor degree in Department Electrical Engineering at Hasanuddin University Makassar. His research interests include renewable energy, sensor networks and environment management system.