

# Unified Power Quality Conditioner for Voltage Sag and Harmonic Mitigation of Nonlinear Loads

<sup>1</sup>Y.Kusuma Latha, <sup>2</sup>Ch.Saibabu, <sup>3</sup>Y.P.Obulesu

<sup>1,3</sup>Department of EEE, Lakireddy Balireddy College of Engineering (Autonomous), Mylavaram-521230, A.P, India

<sup>2</sup>Department of Electrical Engg, University College of Engineering (Autonomous), JNTUk, Kakinada, A.P, India

e-mail: [kusumalathay@gmail.com](mailto:kusumalathay@gmail.com), [chs\\_eee@yahoo.co.in](mailto:chs_eee@yahoo.co.in), [ypobulesu@gmail.com](mailto:ypobulesu@gmail.com)

## Abstract

*With the wide application of nonlinear and electronically switched devices in distribution systems, the power quality problem becomes more serious. This paper deals with Unified Power Quality Condition (UPQC) which is an integration of series active filter and shunt active filter. The main purpose of a UPQC is to compensate for current harmonics and voltage harmonics. It has the capability of improving power quality at the point of installation on power distribution systems. The paper discusses the compensation principle and different control strategies of the UPQC in detail. The performance of UPQC is examined by considering, a diode rectifier feeding an RL load (non linear load) that acts as a source of harmonics, feeding harmonics into the three-phase distribution system of concern. The performance is also observed under influence of utility side disturbances such as sag, swell, and flicker. This control strategy guarantees sinusoidal, balanced and minimized source currents even under unbalanced and / or distorted system voltages. The control strategies are modeled using MATLAB/SIMULINK and simulation results are presented to validate the proposed control strategy.*

**Keywords**—UPQC, Power Quality, Harmonics, Load Balancing, Power Factor Correction, MATLAB/SIMULINK.

## 1. Introduction

Solid state power converters are widely used in applications such as adjustable speed drives (ASD), static power supplies and asynchronous ac-dc links in wind and wave generating systems[1]. These power converters behave as non-linear loads to ac mains and inject harmonics and result in low power factor and efficiency of the system [2,3]. Conventionally passive filters were the choice for the elimination of the harmonics and to improve the power factor. These passive filters have the disadvantage of larger size, resonance and fixed compensation. In the last couple of decades, the concept of active power filters (APF), SVC and ASVC are very popular [3],[4]. Several approaches such as hybrid filters and multi step inverters are proposed to reduce the size of the active filters. Many control concepts such as instantaneous power theory, notch filter and flux based controllers have also been introduced. Most of these schemes require transformations and are difficult to implement. Instantaneous symmetrical component theory is a very easy scheme to implement in the real time process as there are no complications of transformations as well as reduced computation. The stiff source is the only requirement to be met in order to use this scheme as control algorithm [5].

Voltage sag is one of the prime factors due to which particularly production industries suffer huge loss [6]. This is evident from many power quality survey reports. Most of these voltage sensitive critical loads are non-linear in nature due to application of fast acting semiconductor switches and their specific control strategy[7,8]. Undoubtedly they have revolutionized the state of the art of technology in almost every field, but their large-scale presence in a system pose some major concerns as they affect the distribution utility in some highly undesirable ways.

Primarily, these kinds of load currents are rich in harmonics and they may require some reactive VA as well. The harmonic currents flowing through the finite source impedance of the utility supply cause the voltage distortion at the Point of Common Coupling (PCC) to the other loads [9]. It results in malfunction of control signals, protection and metering of other loads and system metering devices. But the discussions focus on separated compensation for reactive power, negative-sequence current or harmonics. Recent research efforts have been made towards utilizing a device called unified power quality conditioner (UPQC) to solve almost all power quality problems [10].

The aim of the paper is to design different control strategies for Unified Power Quality Conditioner (UPQC), which is one of the major custom power solutions capable of mitigating the effect of supply voltage sag and swell at the load end or at the Point of Common Coupling (PCC). It also prevents load current harmonics from entering the utility and corrects the input power factor of the load and also eliminates the distortion in the voltage caused due to flickering, spikes etc. In this paper the control strategies are implemented with PI Controller.

## 2. Proposed control strategies

The prime objective of power utility companies is to provide their consumers an uninterrupted sinusoidal voltage of constant amplitude. In addition to this, adherence to different power quality standards laid down by different agencies has become a figure of merit for the power utilities [1-3]. Unfortunately, this is becoming increasingly difficult to do so, because the size and number of non-linear and poor power-factor loads such as adjustable speed drives, computer power supplies, furnaces, power converters and traction drives are finding its applications at domestic and industrial levels. These nonlinear loads draw non-linear current and degrade electric power quality. The quality degradation leads to low power-factor, low efficiency, overheating of transformers and so on [4]. Apart from this, the overall load on the distribution system is seldom found to be balanced. In the past, efforts have been made to mitigate these identified power quality problems using conventional passive filters. But their limitations such as, fixed compensation, resonance with the source impedance and the difficulty in tuning time dependence of filter parameters [3] have ignited Unified Power Quality Controller is a novel approach proposed in the direction of attaining better quality of power in the distribution networks. The basic construction of the UPQC is very much similar to that of Unified Power Flow Controller (UPFC). The basic building blocks of UPQC, and their inter connection is as shown in Fig.1.

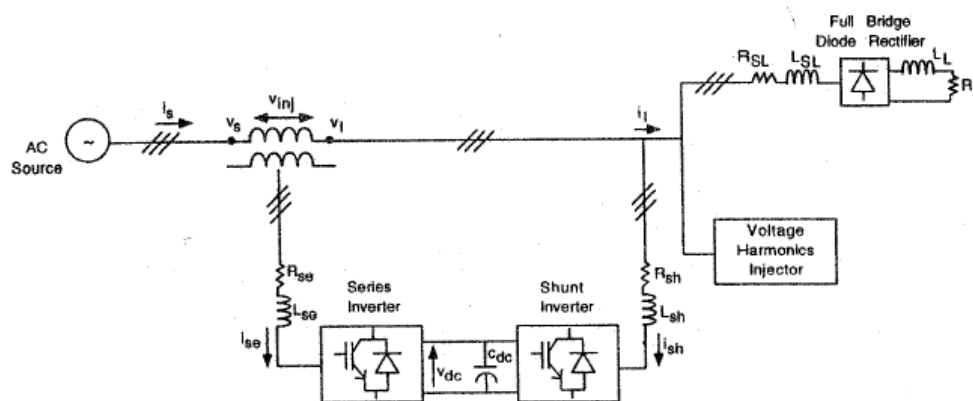

Fig 1 General configuration of Unified Power Quality Conditioner

The UPQC consists of two back to back connected IGBT based voltage source bi-directional converters with a common dc bus. One inverter is connected in series, while the other one is placed in shunt with the nonlinear load. The inverter connected in shunt with the load acts as a current source for injecting compensating current,  $i_c$ . While, the supply side inverter connected in series with the load acts as a voltage source feeding compensating voltage,  $v_c$  through an insertion transformer. A diode bridge rectifier feeding R-L load is considered as nonlinear load.

### 2.1 Active Filtering System

The active filters are very quick in responding to any power disturbance compared to passive filters. The real power system undergoes many transients, which are enough quicker that these cannot be addressed using a simple passive filter assembly. This made power system analyzers to go to active filters, which acts, based on the philosophy that addresses the load current distortion from a time domain rather than a frequency domain approach. The most effective way to improve the distorted power factor in a non-sinusoidal situation is to use a nonlinear active device that directly compensates for the load current distortion.

The performance of these active filters is based on three basic design criteria. They are:

- The design of the power inverter (semiconductor switches, inductances, capacitors, dc voltage).
- The PWM control method (hysteresis, triangular carrier, periodical sampling)
- Method used to obtain the current reference or the control strategy used to generate the reference template.

### 2.2 Design of power inverters

**Inverters:** Both series voltage control and shunt current control involve use of voltage source converters. Both these inverters are operated in current control mode employing PWM control technique.

Each three-phase voltage source converter consists of six controllable switches and each switch is nothing but an IGBT with a parallel diode connected in reverse. Thus each leg of a three-phase voltage source converter consists of two switches. Since the converters are bi-directional, currents flow from ac to dc and vice versa. Diodes carry out instantaneous rectifier operation and IGBT's carry out instantaneous inverter operation.

**Capacitor:** Capacitor is used as an interface between the two back to back connected inverters and the voltage across it acts as the dc voltage source driving the inverters. Thus, the capacitor that acts as an energy storage device is shared between the two bi-directional converters. The voltage across the capacitor is held constant at the required value using closed loop control. In order to assure the filter current at any instant, the DC voltage,  $V_{dc}$  must be at least equal to  $3/2$  of the peak value of the line AC mains voltage. The capacitor is to be so designed so as to provide DC voltage with acceptable ripples.

**Interface Inductor:** An inductor is used to interface the filter (either shunt or series) with the distribution system. That is, the generated ac voltage (generated by the inverter) is connected to the ac system via an inductor. Therefore, control of the current wave-shape is limited not only by the switching frequency of the inverter but also by the available driving voltage across the interfacing inductor. The driving voltage across the interfacing inductor determines the maximum  $di/dt$  that can be achieved by the filter. This is important because relatively high values of  $di/dt$  may be needed to cancel higher order harmonic components. Therefore, there is a trade-off involved in sizing the interface inductor. A large inductor is better for isolation from the power system and protection from transient disturbances. However, the larger inductor values limit the ability of the filter to cancel higher order harmonics.

## 2.3 Control Strategy to Generate Reference Currents

### 2.3.1 Shunt Control Strategies

Shunt control strategy involves not only generating reference current to compensate the harmonic currents but also charging the capacitor to the required value to drive the inverters.

#### PI Control

With a view to have a self regulated dc bus, the voltage across the capacitor is sensed at regular intervals and controlled by employing a suitable closed loop control. The dc link voltage,  $v_{dc}$  is sensed at a regular interval and is compared with its reference counterpart  $v_{dc}^*$ . The error signal is processed in a PI controller. The output of the PI controller is denoted as  $i_{sp(n)}$ . A limit is put on the output of controller. This ensures that the source supplies active power of the load and dc bus of the UPQC. Later part of active power supplied by source is used to provide a self-supported dc link of the UPQC. Thus, the dc bus voltage of the UPQC is maintained to have a proper current control.

#### Generating compensating current

**Direct method:** The output,  $i_{sp}$  is considered as magnitude of three phase reference currents. Three phase unit current vectors ( $u_{sa}$ ,  $u_{sb}$  and  $u_{sc}$ ) are derived in phase with the three phase supply voltages ( $v_{sa}$ ,  $v_{sb}$  and  $v_{sc}$ ). These unit current vectors ( $u_{sa}$ ,  $u_{sb}$  and  $u_{sc}$ ) form the phases of three phase reference currents. Multiplication of magnitude  $I_{sp}$  with phases ( $u_{sa}$ ,  $u_{sb}$  and  $u_{sc}$ ) results in the three-phase reference supply currents ( $i_{sa}^*$ ,  $i_{sb}^*$  and  $i_{sc}^*$ ). Subtraction of load currents ( $i_{la}$ ,  $i_{lb}$  and  $i_{lc}$ ) from the reference supply currents ( $i_{sa}^*$ ,  $i_{sb}^*$  and  $i_{sc}^*$ ) results in three-phase reference currents ( $i_{sha}^*$ ,  $i_{shb}^*$  and  $i_{shc}^*$ ) for the shunt inverter.

These reference currents  $i_{ref}$  ( $i_{sha}^*$ ,  $i_{shb}^*$  and  $i_{shc}^*$ ) are compared with actual shunt compensating currents  $i_{act}$  ( $i_{sha}$ ,  $i_{shb}$  and  $i_{shc}$ ) and the error signals are then converted into (or processed to give) switching pulses using PWM technique which are further used to drive shunt inverter. In response to the PWM gating signals the shunt inverter supplies harmonic currents required by load. (In addition to this it also supplies the reactive power demand of the load.) In effect, the shunt bi-directional converter that is connected through an inductor in parallel with the load terminals accomplishes three functions simultaneously:

- It injects reactive current to compensate current harmonics of the load
- It provides reactive power for the load and thereby improve power factor of the system
- It also draws the fundamental current to compensate the power loss of the system and make the voltage of DC capacitor constant.

### 2.3.2 Series Control strategies

The series inverter, which is also operated in current control mode, isolates the load from the supply by introducing a voltage source in between. This voltage source compensates supply voltage deviations such as sag and swell. In closed loop control scheme of the series inverter, the three phase load voltage ( $v_{la}$ ,  $v_{lb}$  and  $v_{lc}$ ) are subtracted from the three phase supply voltage ( $v_{sa}$ ,  $v_{sb}$  and  $v_{sc}$ ), and are also compared with reference supply voltage which results in three phase reference voltages ( $v_{la}^*$ ,  $v_{lb}^*$  and  $v_{lc}^*$ ). These reference voltages are to be injected in series with the load. By taking recourse to a suitable transformation, the three phase reference currents ( $i_{sea}^*$ ,  $i_{seb}^*$  and  $i_{sec}^*$ ) of the series inverter are obtained from the three phase reference voltages ( $v_{la}^*$ ,  $v_{lb}^*$  and  $v_{lc}^*$ ). These reference currents ( $i_{sea}^*$ ,  $i_{seb}^*$  and  $i_{sec}^*$ ) are fed to a PWM current controller along with their sensed counterparts ( $i_{sea}$ ,  $i_{seb}$  and  $i_{sec}$ ). The gating signals obtained from PWM current controller ensure that the series inverter meets the demand of voltage sag and swell, thereby providing sinusoidal voltage to load.

Thus series inverter plays an important role to increase the reliability of quality of supply voltage at the load, by injecting suitable voltage with the supply, whenever the supply voltage undergoes sag.

The series inverter acts as a load to the common dc link between the two inverters. When sag occurs series inverter exhausts the energy of the dc link. Thus, unlike Dynamic Voltage Restorer, UPQC does not need any external storage device or additional converter (diode bridge rectifier) to supply the dc link voltage.

## 2.4 Modeling of UPQC

### 2.4.1 Computation of control quantities of shunt inverter

#### Direct current control method:

The amplitude of the supply voltage is computed from the three phase sensed values as:

$$V_{sm} = [2/3(V_{sa}^2 + V_{sb}^2 + V_{sc}^2)]^{1/2} \quad (1)$$

The three phase unit current vectors are computed as:

$$\begin{aligned} u_{sa} &= V_{sa}/V_{sm}; \\ u_{sb} &= V_{sb}/V_{sm}; \\ u_{sc} &= V_{sc}/V_{sm}; \end{aligned} \quad (2)$$

Multiplication of three phase unit current vectors ( $u_{sa}$ ,  $u_{sb}$  and  $u_{sc}$ ) with the amplitude of the supply current ( $i_{sp}$ ) results in the three-phase reference supply currents as:

$$\begin{aligned} i_{sa}^* &= i_{sp} \cdot u_{sa}; \\ i_{sb}^* &= i_{sp} \cdot u_{sb}; \\ i_{sc}^* &= i_{sp} \cdot u_{sc}; \end{aligned} \quad (3)$$

To obtain reference currents, three phase load currents are subtracted from three phase reference supply currents:

$$\begin{aligned} i_{sha}^* &= i_{sa}^* - i_{la}; \\ i_{shb}^* &= i_{sb}^* - i_{lb}; \\ i_{shc}^* &= i_{sc}^* - i_{lc}; \end{aligned} \quad (4)$$

These are the  $i_{ref}$  for Direct current control technique of shunt inverter. The  $i_{ref}$  are compared with  $i_{act}$  in PWM current controller to obtain the switching signals for the devices used in the shunt inverter.

### 2.4.2 Computation of control quantities of series inverter:

The supply voltage and load voltage are sensed and there from, the desired injected voltage is computed as follows:

$$V_{inj} = V_s - V_l \quad (5)$$

The magnitude of the injected voltage is expressed as:

$$V_{inj} = |V_{inj}| \quad (6)$$

Whereas, the phase of injected voltage is given as:

$$\delta_{inj} = \tan(\text{Re}[V_{pq}]/\text{Im}[V_{pq}]) \quad (7)$$

For the purpose of compensation of harmonics in load voltage, the following inequalities are followed:

$$V_{inj} < V_{injmax} \quad \text{magnitude control};$$

$$0 < \delta_{inj} < 360^\circ \quad \text{phase control};$$

Three phase reference values of the injected voltages are expressed as:

$$\begin{aligned}
 v_{1a}^* &= \sqrt{2}v_{inj}\sin(\omega t + \delta_{inj}) \\
 v_{1b}^* &= \sqrt{2}v_{inj}\sin(\omega t + 2\pi/3 + \delta_{inj}) \\
 v_{1c}^* &= \sqrt{2}v_{inj}\sin(\omega t - 2\pi/3 + \delta_{inj})
 \end{aligned}
 \tag{8}$$

The three phases reference currents ( $i_{ref}$ ) of the series inverter are computed as follows:

$$\begin{aligned}
 i_{sea}^* &= v_{1a}^*/Z_{se}; \\
 i_{seb}^* &= v_{1b}^*/Z_{se}; \\
 i_{sec}^* &= v_{1c}^*/Z_{se};
 \end{aligned}
 \tag{9}$$

The impedance  $z_{se}$  includes the impedance of insertion transformer. The currents ( $i_{sea}^*$ ,  $i_{seb}^*$  and  $i_{sec}^*$ ) are ideal current to be maintained through the secondary winding of insertion transformer in order to inject voltages ( $v_{1a}$ ,  $v_{1b}$  and  $v_{1c}$ ), thereby accomplishing the desired task of compensation of the voltage sag. The currents  $i_{ref}$  ( $i_{sea}^*$ ,  $i_{seb}^*$  and  $i_{sec}^*$ ) are compared with  $i_{act}$  ( $i_{sea}$ ,  $i_{seb}$  and  $i_{sec}$ ) in PWM current controller, as a result six switching signals are obtained for the IGBTs of the series inverter. The block diagram used for the proposed control scheme is given in fig 2. The proposed control scheme is implemented using Matlab/Simulink and it is shown in fig 3.

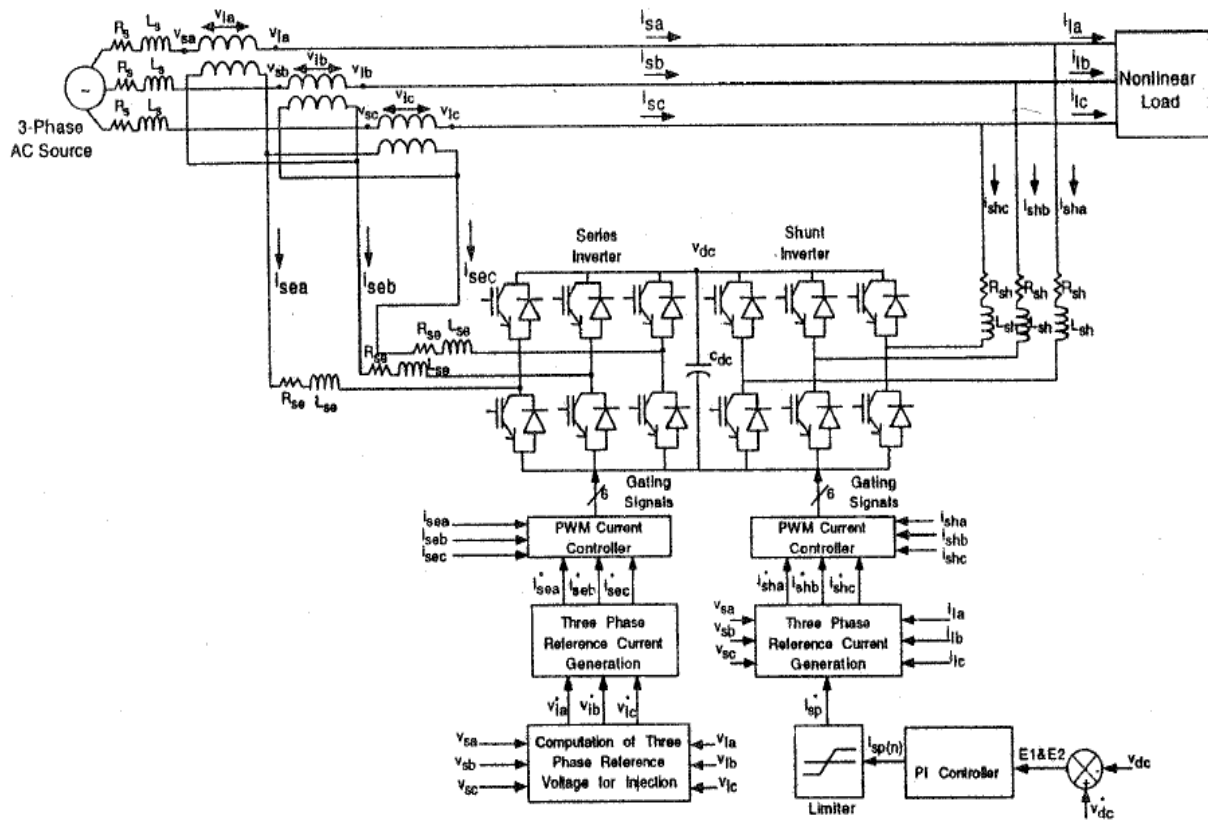

Fig 2 Control Scheme of Three Phase UPQC

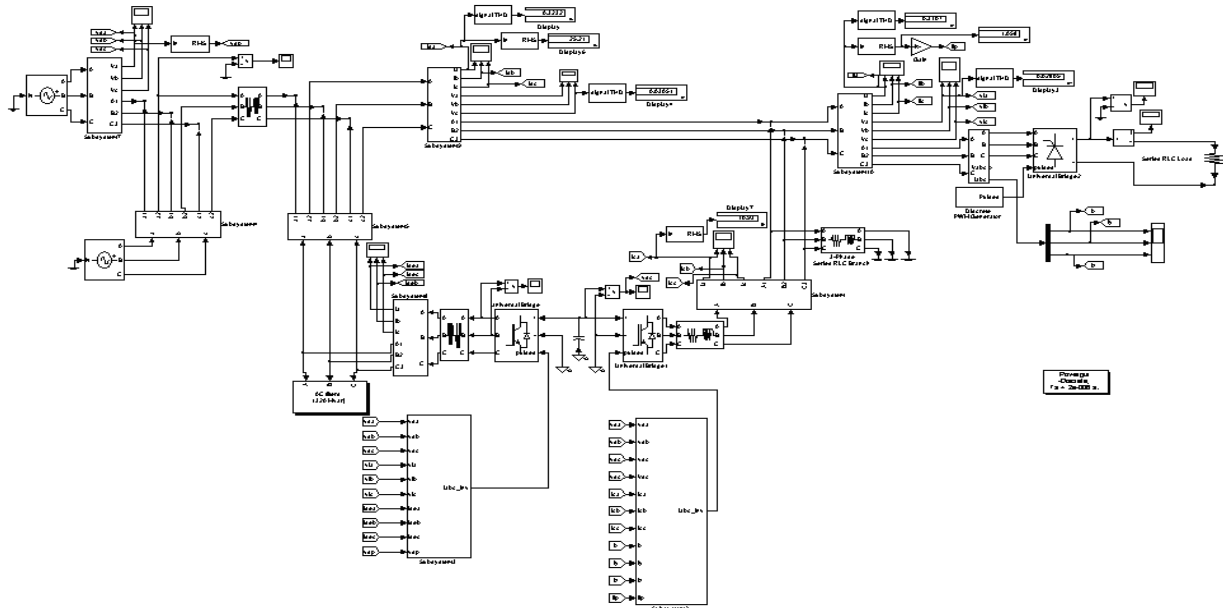

Fig 3 Simulink diagram of UPQC for nonlinear system

### 3. Results and Analysis

A three-phase supply of 230v, 60Hz is considered to feed a diode rectifier fed RL Load (non-linear load). Source impedance is considered almost negligible with  $R_s$  and  $L_s$  values being 0.1ohms and 0.1mH respectively. Both series and shunt inverters are modeled using universal bridges with IGBT/diodes. The values of shunt elements, interfacing shunt inverter and the system are:

$$R_{sh} = 1\text{ohm}, L_{sh} = 30\text{ mH}, C_{sh} = 700\ \mu\text{f}.$$

Apart from this a shunt passive filter and a series passive filter are also used for better compensation. The values of series elements, interfacing series inverter with the system is:

$$R_{se} = 0.1\ \text{ohm}, L_{se} = 12\ \text{mH}.$$

The values of proportional and integral constants of the PI controller are taken to be 0.5 and 500 respectively. The value of the capacitor providing dc link voltage is 700 $\mu\text{f}$ .

Flicker is introduced using an insertion transformer whose magnitude is 10% of the base voltage. Spikes are introduced in similar manner with a magnitude of 15% of the base voltage. Two filters are used one at series inverter terminals the other at the shunt inverter terminals.

The current and voltage waveforms are shown in Fig 4 to 12 for without and with voltage flicker for without and with UPQC. From the results, it is noticed that the UPQC improves the performance of the supply system.

#### 3.1 Without UPQC

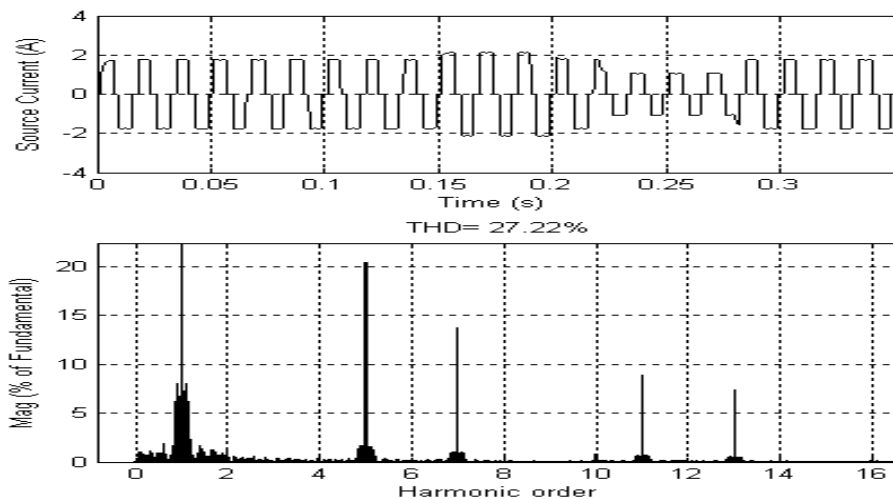

Fig 4. Source current with harmonic spectrum

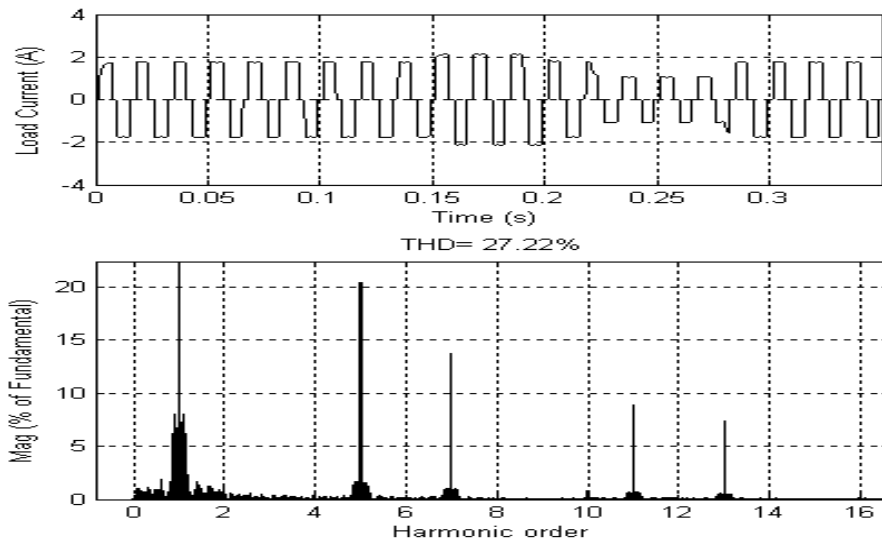

Fig 5. Load current with harmonic spectrum

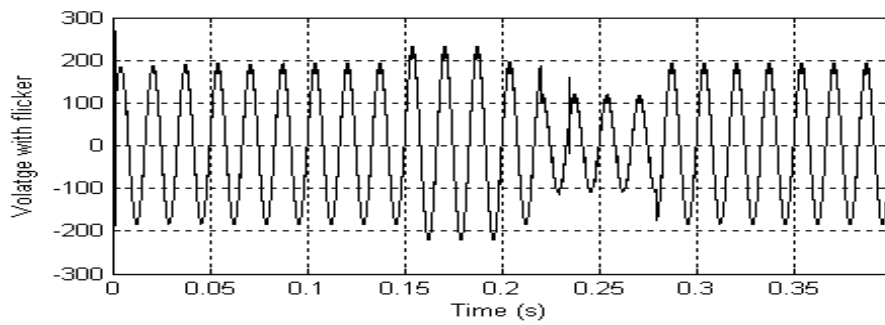

Fig 6. Voltage flicker

3.2 With UPQC

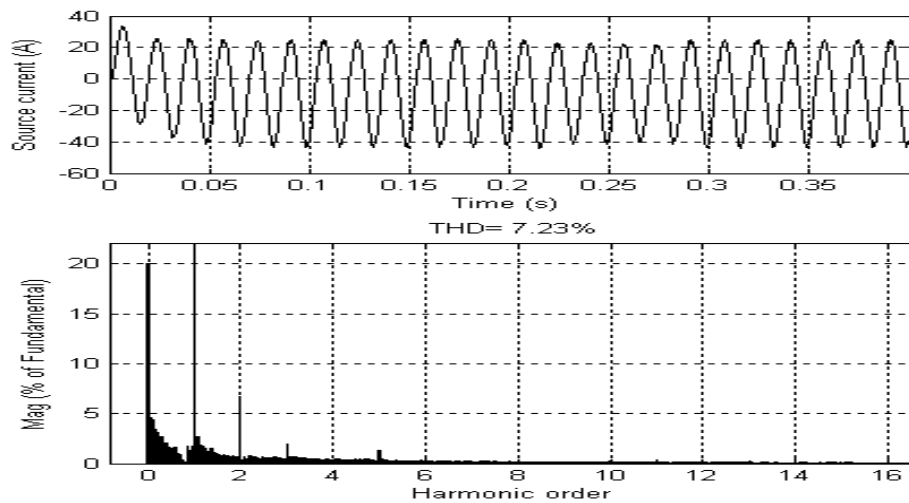

Fig 7. Source current with harmonic spectrum

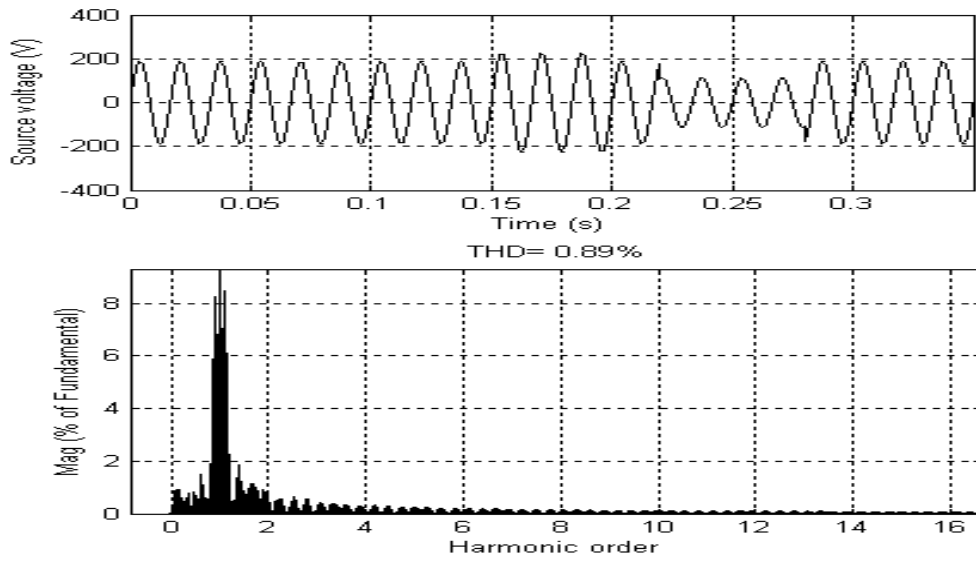

Fig 8. Source voltage with flicker

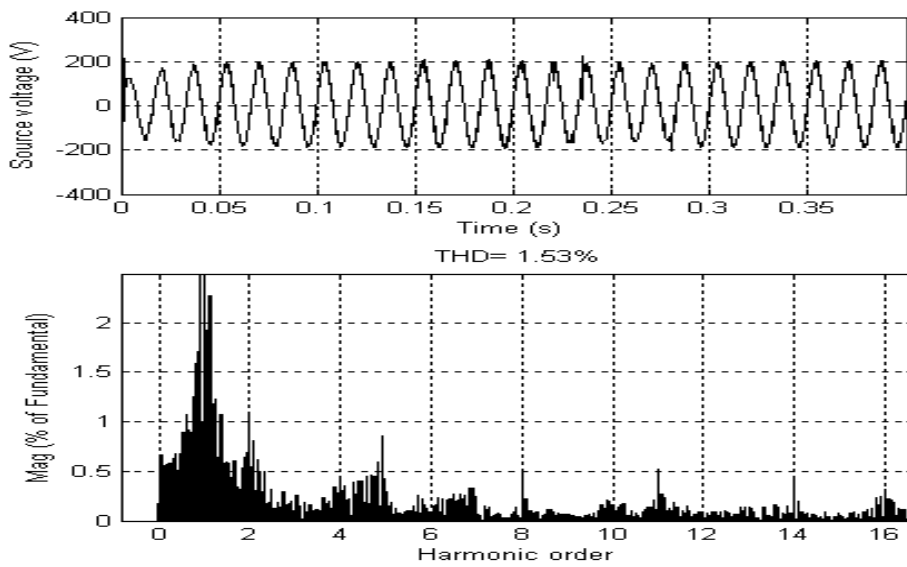

Fig 9. Source voltage with harmonic spectrum

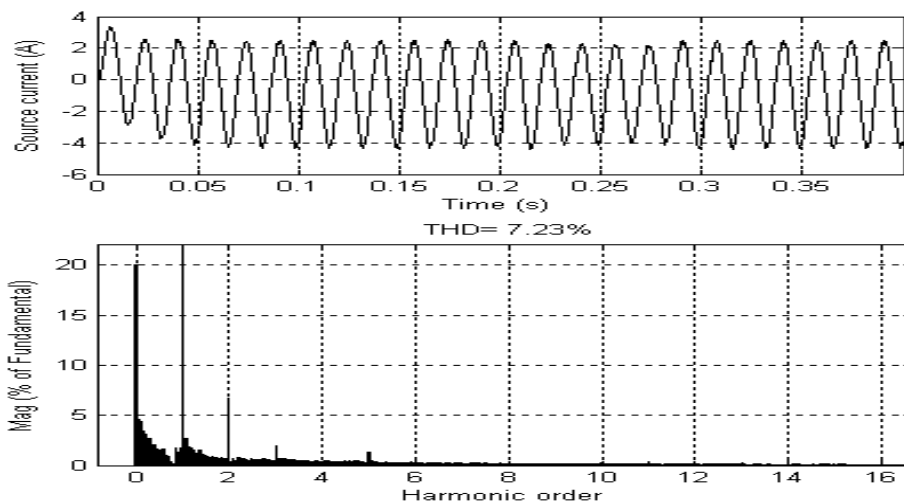

Fig 10. Source current without flicker



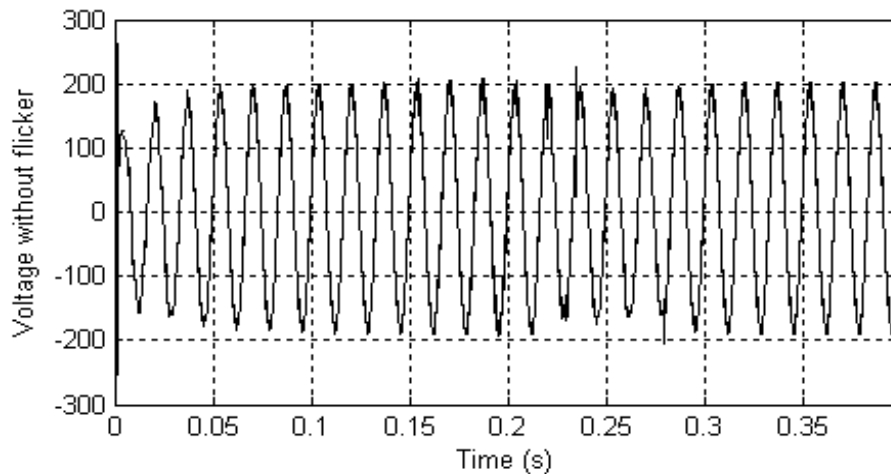

Fig 11. Source voltage without flicker

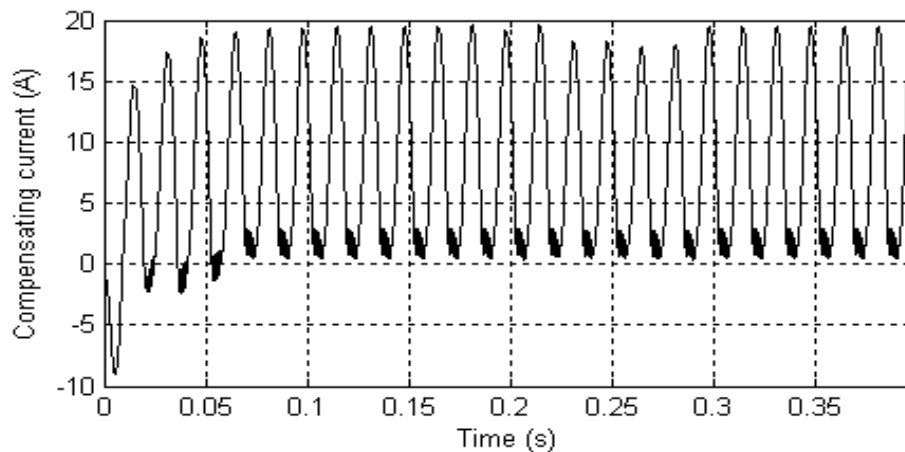

Fig 12. Compensating current

#### 4. Conclusion

The UPQC uses two back to back connected three phase voltage source inverters sharing a common dc bus. These two inverters constitute series active filter and shunt active filter, are used in power system networks where the loads disturb the quality of the supply. Results of the UPQC proved that the performance of the UPQC examined in direct current control technique is improved. It is found that the UPQC offers a satisfactory level of performance and it is effective towards compensating the harmonics in current and voltage along with the reactive power demand of the nonlinear load. It also controls the voltage flicker effectively

#### References

- [1] H. Akagi, "New Trends in Active Filter for power conditioning", *IEEE Trans. Ind. Application*, vol. 32, no. 6, pp. 1312-1322, 1996
- [2] H. Fujita and H. Akagi, "The Unified Power Quality Conditioner: The Integration of Series- and shunt active filters", *IEEE Trans. Power Electronics*, vol. 13, no. 2, pp. 315-322, 1998
- [3] Mauricio Aredes, Klemens Heumann and Edson H. Walmale, "A Universal Active Power Line Conditioner". *IEEE Trans. On Power Delivery*, vol. 13, no. 2, pp. 545-551, 1998
- [4] B. Singh, AL.K. Haddad and A. Chandra, "A review of active filters for power quality improvement," *IEEE Trans. on Ind. Electron*, vol.46, pp. 960-971, 1999.
- [5] Yunping Chen, Xiaoming Zha and Jin Wang etc." *Unified Power Quality Conditioner (UPQC): The Theory, Modeling and Application*". *Power System Technology, 2000 proceedings. Power Con 2000. International Conference on*, vol. 3, pp. 1329-1333, 2000

- [6] Prodanovic, M. and T.C. Green, "Control and filter design of three-phase inverters for high power quality grid connection". *IEEE Transactions on Power Delivery*, 18(1): 373-380, 2003
- [7] V.Khadkikar, P. Agarwal, A.Chandra, A.O. Barry and T.D. Nguyen, "A simple new control technique for unified power quality conditioner (UPQC)," *Proc. on.Harmonics and Quality of Power*, pp289-293, Sept.2004
- [8] B.Singh,V. Verma,A. Chandra and K. Al-Haddad, " Hybrid filters for power quality improvement,"*Proc. IEE on Generation, Transmission and Distribution*, vol.152,pp.365-378,May2005.
- [9] Han B., B. Bae, H. Kim, S. Baek. "Combined Operation of Unified Power Quality Conditioner With Distributed Generation". *IEEE Transactions on Power Delivery*, 21: 330-338, , 2006
- [10] Han, B., B. Bae, S. Baek, G. Jang. "New configuration of UPQC (unified power quality conditioner) for medium-voltage application". *IEEE Transactions on Power Delivery*, 21(3): 1438-1444, , 2006

### Bibliography of authors



**Y.Kusuma latha** received the B.E (Electrical and Electronics Engineering) degree from Nagarjuna University, Guntur.A.P, India, M.Tech degree from Jawaharlal Nehru Technological University, Anantapur, India in 2000 and 2004. Currently she is working for her Ph.D. She is working as an Associate Professor in the Dept. of Electrical and Electronic Engineering, at Lakireddy Balireddy College of Engineering (Autonomous),Mylavaram. Her areas of interest are Power Quality, Harmonic mitigation techniques, Active power filters and DSP Controllers



**Ch. Sai Babu** received the B.E from Andhra University (Electrical & Electronics Engineering), M.Tech in Electrical Machines and Industrial Drives from REC, Warangal and PhD in Reliability Studies of HVDC Converters from JNTU, Hyderabad. Currently he is working as a Professor in Dept. of EEE in JNTUCEK, Kakinada. He has published several papers in National and International Journals and Conferences. His area of interest is Power Electronics and Drives, Power System Reliability, HVDC Converter Reliability, Optimization of Electrical Systems and Real Time Energy Management.



**Y. P. Obulesu** received his B.E degree in Electrical Engineering from Andhra University, Visakhapatnam, India, M.Tech degree from Indian Institute of Technology, Kharagpur, India, in 1996 and 1998.He received his PhD degree from Jawaharlal Nehru Technological University, Hyderabad, in 2006. He got publications in several National and International Journals and Conferences. His areas of interest are simulation and design of power electronics systems, Active filters, Power quality, fuzzy logic and neural network application to power electronics and drives